

Apr.1.2017 Copyright 2017 HIROSE ELECTRIC CO., LTD. All Rights Reserved.

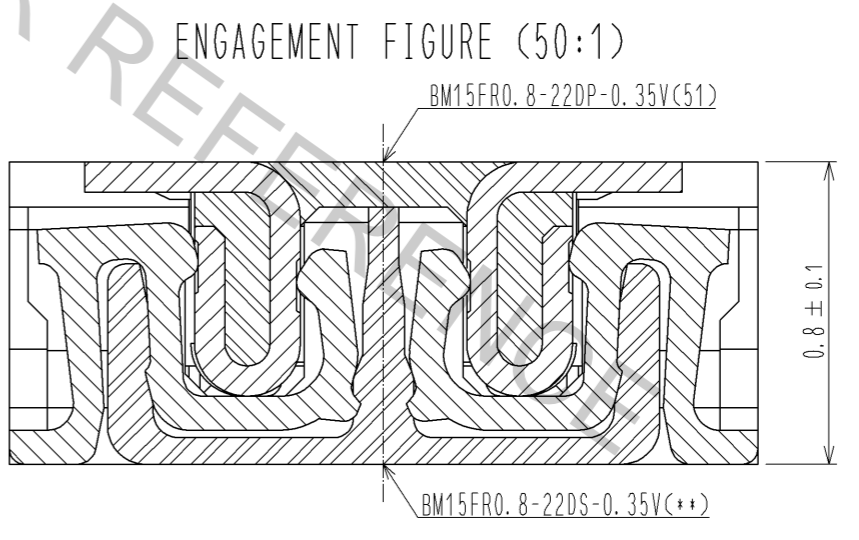
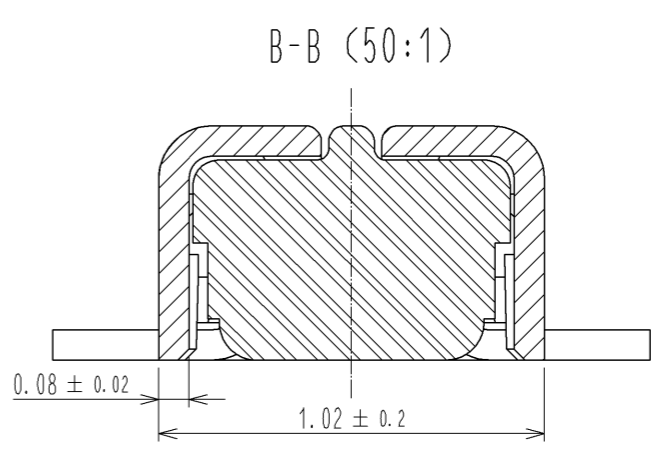
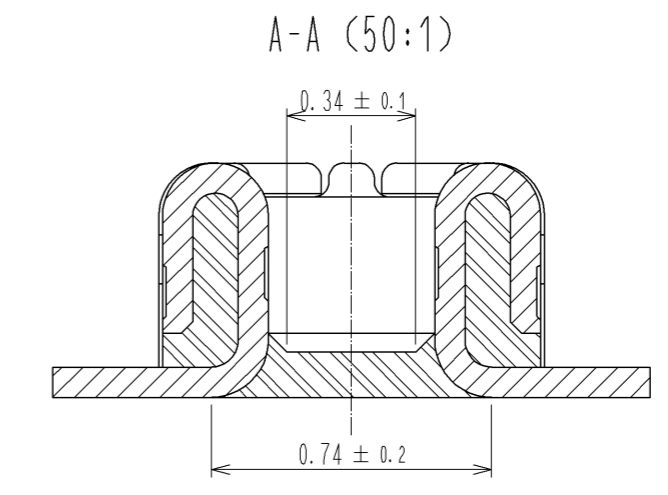
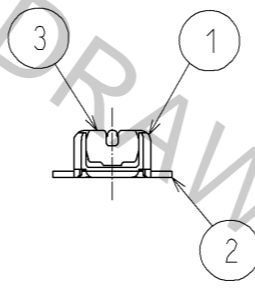
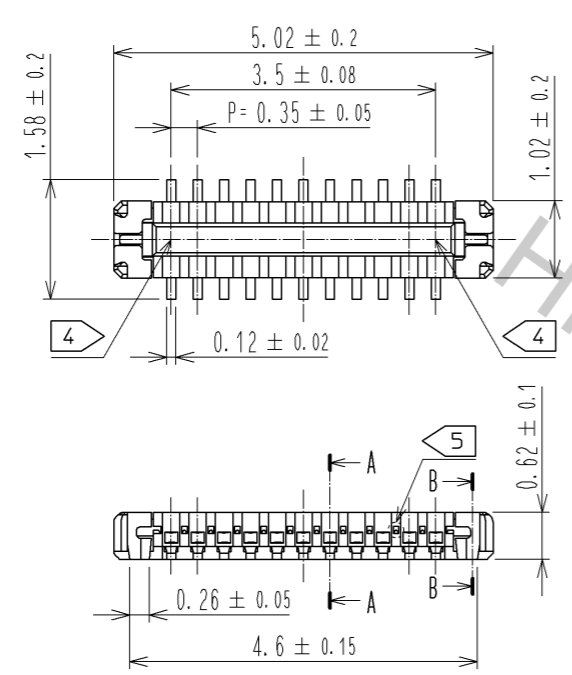

- NOTE) 1 . ALL LEAD CO-PLANARITY SHALL BE 0.08mm MAX
- 2 CONTACT PLATING SPECIFICATIONS
 CONTACT AREA : GOLD 0.05 μm MIN
 SMT LEAD : GOLD 0.05 μm MIN
 UNDERPLATING : NICKEL 1 μm MIN
 (SURFACE : SEALING)
- 3 REINFORCED METAL FITTINGS LOCK
 SMT LEAD : GOLD 0.05 μm MIN
 UNDERPLATING : NICKEL 1 μm MIN
 (SURFACE : SEALING)
- 4 CAV No. AND HRS MARK MYE BE INDICATED IN APPROX POSITION SHOWN.
- 5 A PART OF THE WALL COULD BE NOTCHED.

NO.	MATERIAL	FINISH .	REMARKS	NO.	MATERIAL	FINISH .	REMARKS
4	PS		CLEAR (ENBOSSED CARRIER TAPE)				
3	PHOSPHOR BRONZE	3		7	PS		CLEAR (REINFORCEMENT COLLAR)
2	PHOSPHOR BRONZE	2		6	PS		BLACK (PLASTIC REEL)
1	LCP		UL94 V-0, BLACK	5	POLYESTER		CLEAR (COVER TAPE)

UNITS	SCALE	COUNT	DESCRIPTION OF REVISIONS	DESIGNED	CHECKED	DATE
mm	10 : 1	△				
APPROVED : KH. IKEDA			13.12.05	DRAWING NO. EDC3-355558-01		
CHECKED : YH. MICHIDA			13.12.05	PART NO. BM15FR0.8-22DP-0.35V(51)		
DESIGNED : YK. KOBAYASHI			13.12.02	CODE NO. CL673-1224-2-51		
DRAWN : YK. KOBAYASHI			13.12.02	△ 1/3		

◆ RECOMMENDED PCB LAYOUT

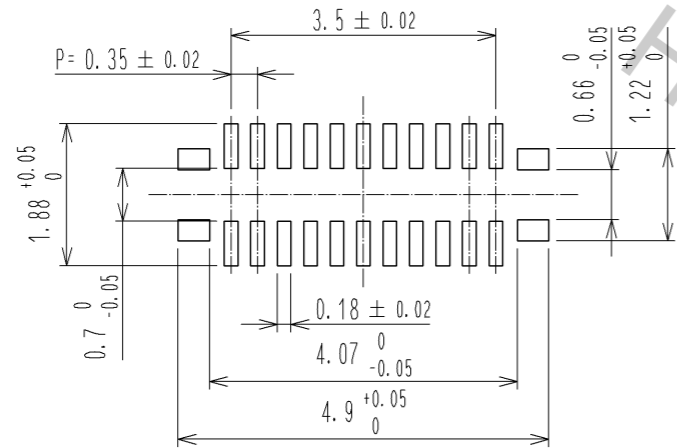

◆ RECOMMENDED METAL MASK DIMENSIONS

METAL MASK THICKNESS : 100 μm

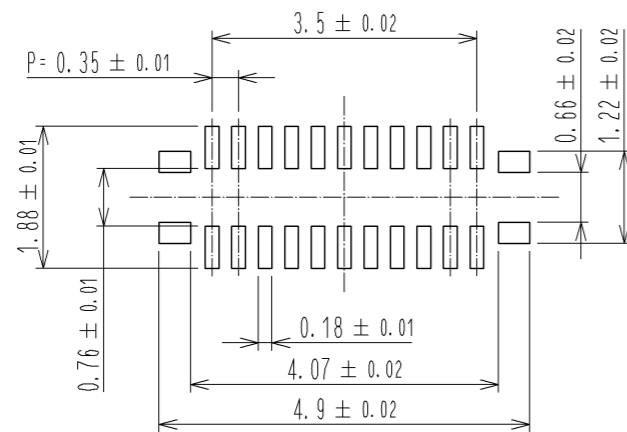

6 RECOMMENDED REFLOW TEMPERATURE PROFILE USING LEAD-FREE SOLDER PASTE.

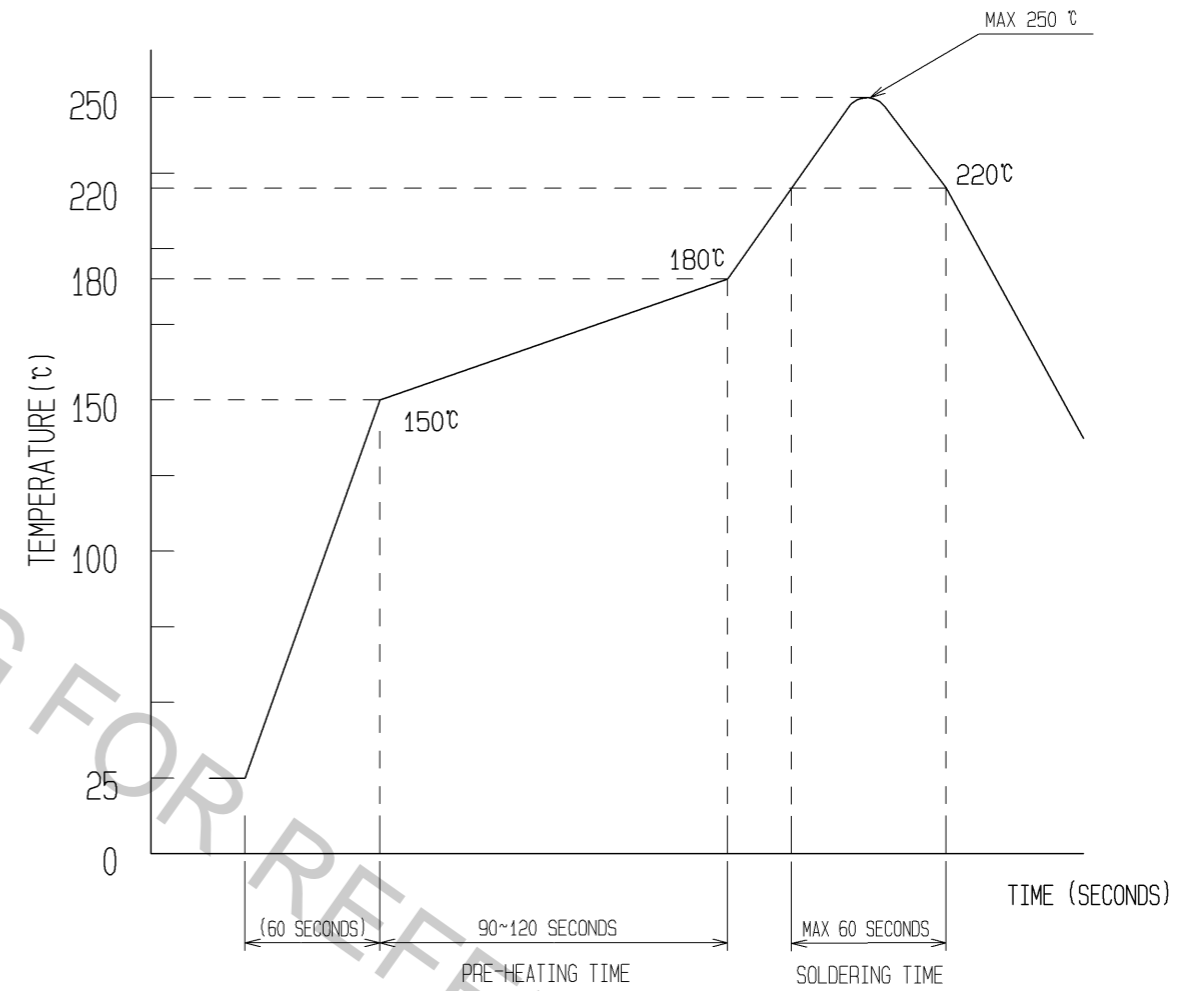

- REFLOW METHOD: IR REFLOW
 NUMBER OF REFLOW CYCLES: 2 CYCLES MAX.
- REFLOW TIME
 DURATION ABOVE 220°C, 60 SEC. MAX.
 (PEAK TEMPERATURE: 250°C MAX)
 - PRE-HEAT TIME
 PRE-HEAT TEMPERATURE(MIN): 150°C
 PRE-HEAT TEMPERATURE(MAX): 180°C
 PRE-HEAT TIME: 90-120 sec.

6 THIS TEMPERATURE PROFILE IS PER THE CONDITIONS SHOWN ABOVE. ADDITIONAL FACTORS, SUCH AS SOLDER PASTE TYPE, PCB SIZE AND OTHER MOUNTED COMPONENTS COULD AFFECT THE PROFILE, THEREFORE, A THOROUGH EVALUATION OF MOUNTING CONDITION IS REQUIRED PRIOR TO PRODUCTION. TEMPERATURE IS MEASURED AT CONTACT LEAD.

HRS	DRAWING NO.	EDC3-355558-01
	PART NO.	BM15FR0.8-22DP-0.35V<51>
	CODE NO.	CL673-1224-2-51

ENBOSSED CARRIER TAPE PACKAGING (5:1)

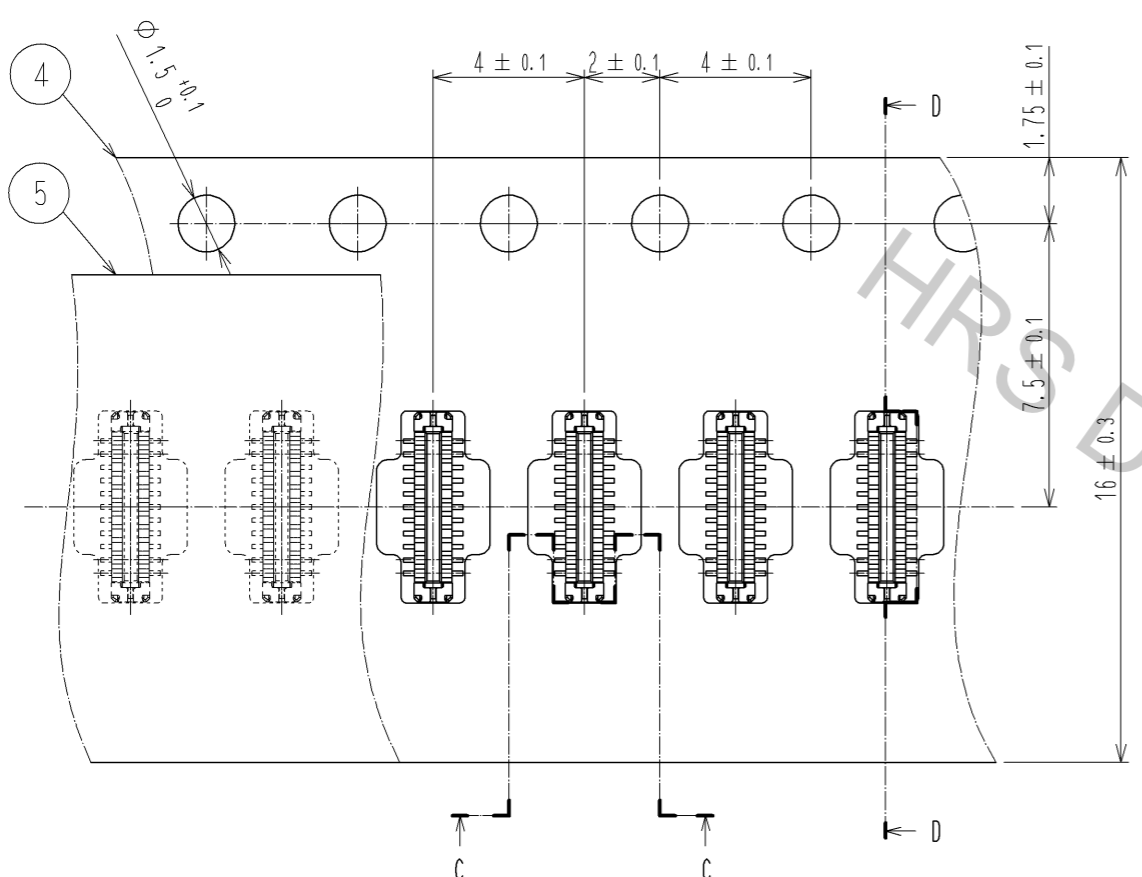

C-C (5:1)

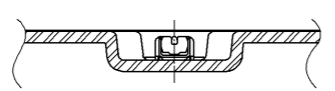

DIRECTION OF UNREELING \rightarrow

D-D (5:1)

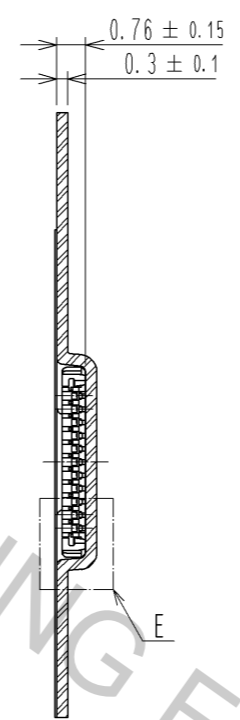

STYLE AND DIMENTION OF REEL (FREE)

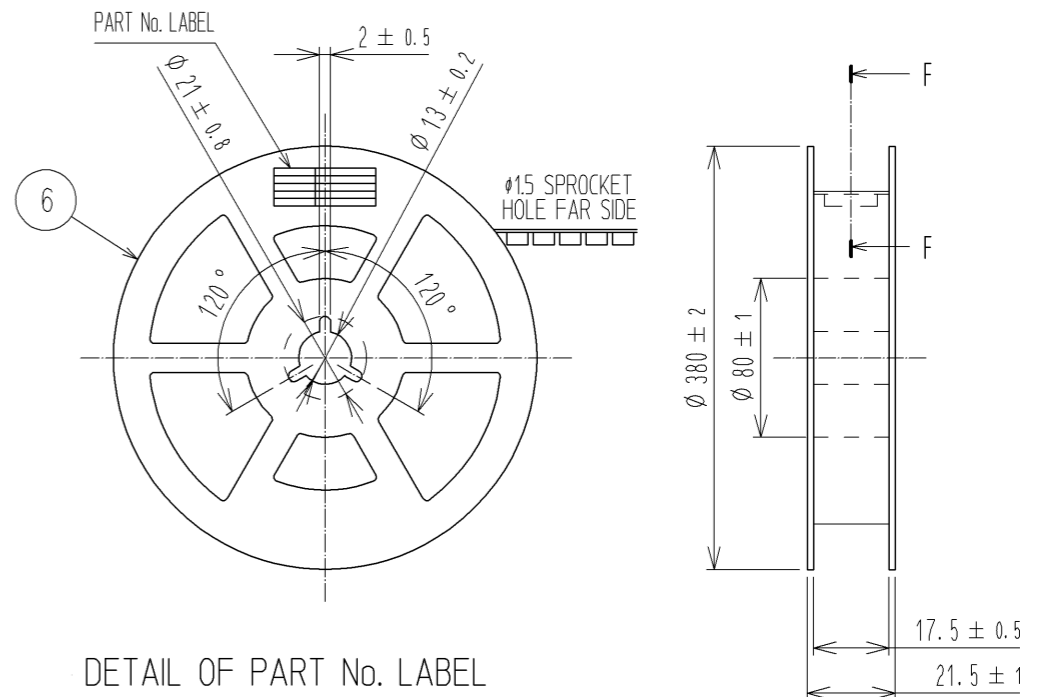

DETAIL OF PART No. LABEL

SUPPLIER	
QUANTITY	
PART No.	
CODE No.	
DATE OF MANUFACTURED	
製造年月日	** ** *
製品コード	CL673-1224-2-51
製品名	BM15FR0. 8-22DP-0.35V(51)
数量	15,000
納入者	ヒロセ電機(株)

F-F (FREE)

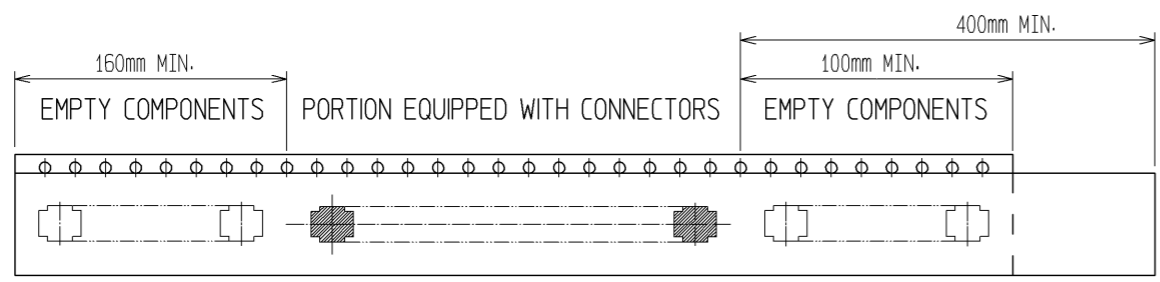
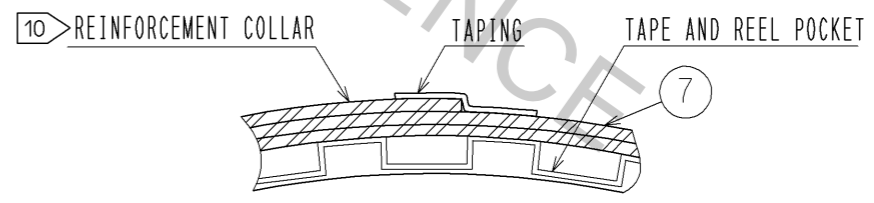

TAPING (FREE)

E(10:1)

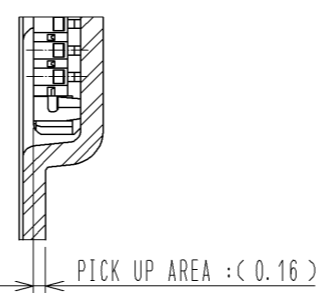

- 7. PER REEL 15000 CONNECTORS.
- 8. THE DIMENSIONS IN PARENTHESSES ARE FOR REFERENCE.
- 9 REFER TO JIS C 0806 AND IEC 60286-3 (PACKAGING OF COMPONENTS FOR AUTOMATIC HANDLING)
- 10 AFTER PACKAGING, ROLL 2 METERS OF THE REINFORCEMENT COLLAR TO OUTER CIRCUMFERENCE OF TAPE AND REEL POCKET, AND TAPE DOWN AT THE END THE COLLAR.

HRS	DRAWING NO.	EDC3-355558-01
	PART NO.	BM15FR0. 8-22DP-0.35V(51)
	CODE NO.	CL673-1224-2-51
		\triangle 3/3