

S P E C I F I C A T I O N

A X I A L L E A D I N D U C T O R S

L A L 0 3 T Y P E

.....

.....

.....

.....

(1 / 7)	Specifications
	AXIAL LEAD INDUCTORS

1. Scope

These specifications apply to automatically inserting small axial lead inductor, LAL03 Type.

2. Naming method

Example of Our Naming Method:

<u>LA</u>	<u>L</u>	<u>03</u>	<u>TA</u>	<u>101</u>	<u>K</u>
(1)	(2)	(3)	(4)	(5)	(6)

- (1) Basic classifications of type name
- (2) Specified characteristic "L"
- (3) Guide for outer dimensions
- (4) Shape of lead
- (5) Inductance value
- (6) Tolerance of inductance

3. Electrical performance

Standards

Refer to Table 1 and 3

Measurement Methods

Inductance	: LCR meter	(Equivalent to HP 4285A+42851A)
Q	: LCR meter	(Equivalent to HP 4285A+42851A)
Self-resonance frequency	: Network analyzer	(Equivalent to Anritsu MS620J)
DC resistance	: Low ohm meter	(Equivalent to A&D AD-5812)

Inductance and Q are in accordance with our standard measurement figures.

Standard test conditions

Unless specified, all tests shall be conducted under the conditions of 20 ± 15 °C temperature and 65 ± 20 % humidity as specified.

Should any doubt arise in determination of test results, a further test shall be conducted under the condition of 20 ± 2 °C temperature and 65 ± 5 % humidity. Also, unless specified, the shape of lead shall be the straight-type.

4. Appearance, dimensions and shape of lead

Standard: Refer to table 2

5. Mechanical performances

Standard: Refer to table 3

6. Environment test performances

Standard: Refer to table 3

7. Structural diagram

Standard: Refer to table 4

8. Color code

Standard: Refer to table 5

※ Please don't wash with supersonic waves.

(2/7)	Table 1
	AXIAL LEAD INDUCTORS

ITEM	INDUC-TANCE (μ H)	TOLE-RANCE (%)	Q min	S.R.FREQ (MHz) min	D.C. RESISTANCE (Ω) max	RATED CURRENT (mA) max	MEASURING FREQUENCY (MHz)
R22M	0.22	± 20	35	450	0.40	400	25.2
R27M	0.27	"	"	410	0.43	380	"
R33M	0.33	"	"	360	0.48	370	"
R39M	0.39	"	"	300	0.51	350	"
R47M	0.47	"	"	230	0.56	330	"
R56M	0.56	"	40	210	0.61	320	"
R68M	0.68	"	"	190	0.67	310	"
R82M	0.82	"	"	170	0.74	290	"
1R0M	1.0	"	"	150	0.80	270	"
1R2M	1.2	± 20	50	144	0.90	260	7.96
1R5M	1.5	"	"	131	1.0	250	"
1R8M	1.8	"	"	121	1.1	240	"
2R2M	2.2	"	"	110	1.2	230	"
2R7M	2.7	"	"	100	1.3	220	"
3R3K	3.3	± 10	"	94	1.4	210	"
3R9K	3.9	"	"	65	1.6	200	"
4R7K	4.7	"	"	56	1.7	190	"
5R6K	5.6	"	"	48	1.9	180	"
6R8K	6.8	"	"	37	2.0	175	"
8R2K	8.2	"	"	25	2.2	165	"
100K	10	"	"	21	2.5	160	"
120K	12	± 10	50	19	2.5	150	2.52
150K	15	"	"	17	2.8	145	"
180K	18	"	"	13	3.1	140	"
220K	22	"	"	9.6	3.4	130	"
270K	27	"	"	7.2	3.8	125	"
330K	33	"	"	6.3	4.1	120	"
390K	39	"	"	6.3	4.5	115	"
470K	47	"	"	6.3	4.9	110	"
560K	56	"	"	6.2	5.3	105	"
680K	68	"	"	5.7	5.8	100	"
820K	82	"	"	5.3	6.3	95	"
101K	100	"	"	4.8	7.0	90	"
121K	120	± 10	50	3.8	13	90	0.796
151K	150	"	"	3.5	15	85	"
181K	180	"	"	3.3	16	80	"
221K	220	"	"	3.0	17	75	"
271K	270	"	"	2.8	19	65	"
331K	330	"	"	2.6	20	60	"
391K	390	"	"	2.4	22	55	"
471K	470	"	"	2.25	24	55	"
561K	560	"	"	2.10	26	50	"
681K	680	"	"	1.95	28	45	"
821K	820	"	"	1.85	30	40	"
102K	1000	"	"	1.40	33	40	"

(3/7)	Table 2
	AXIAL LEAD INDUCTORS

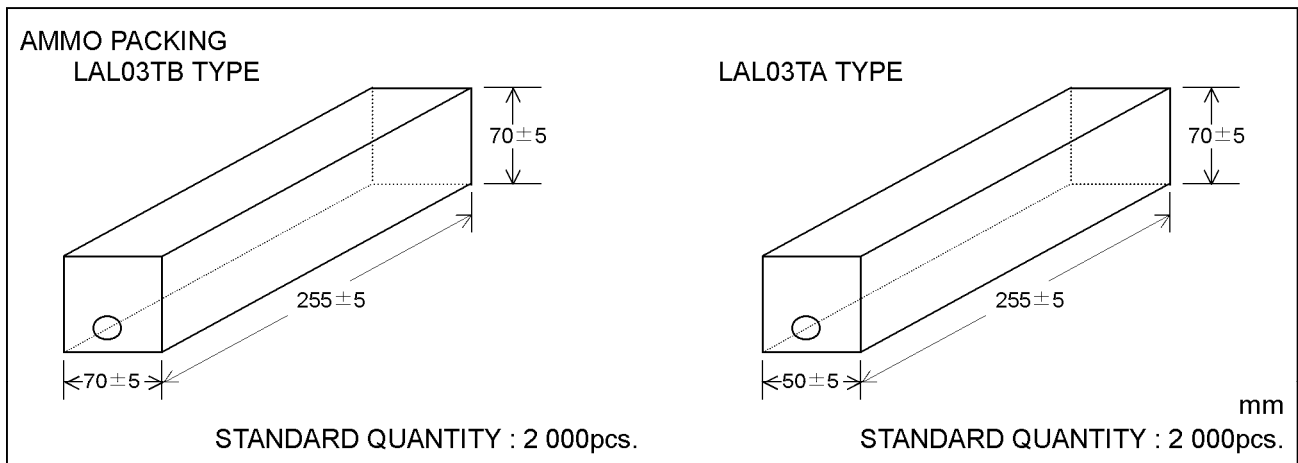
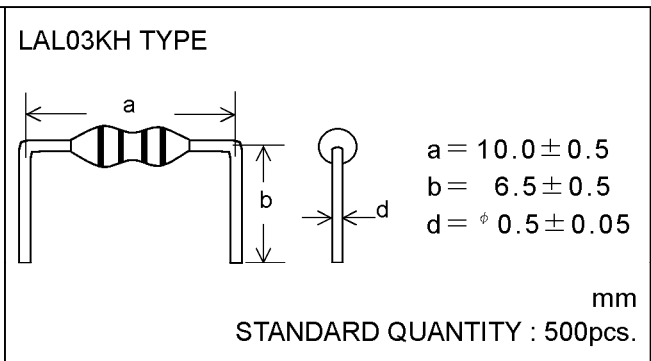
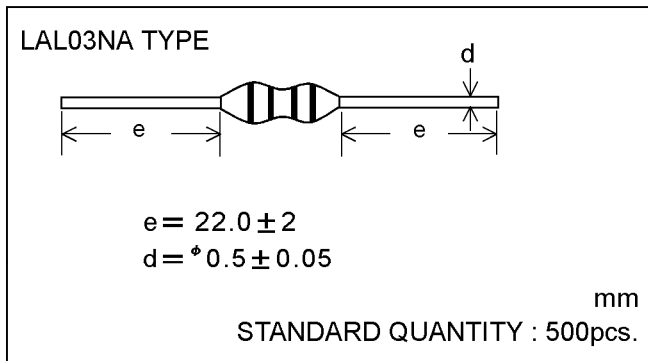
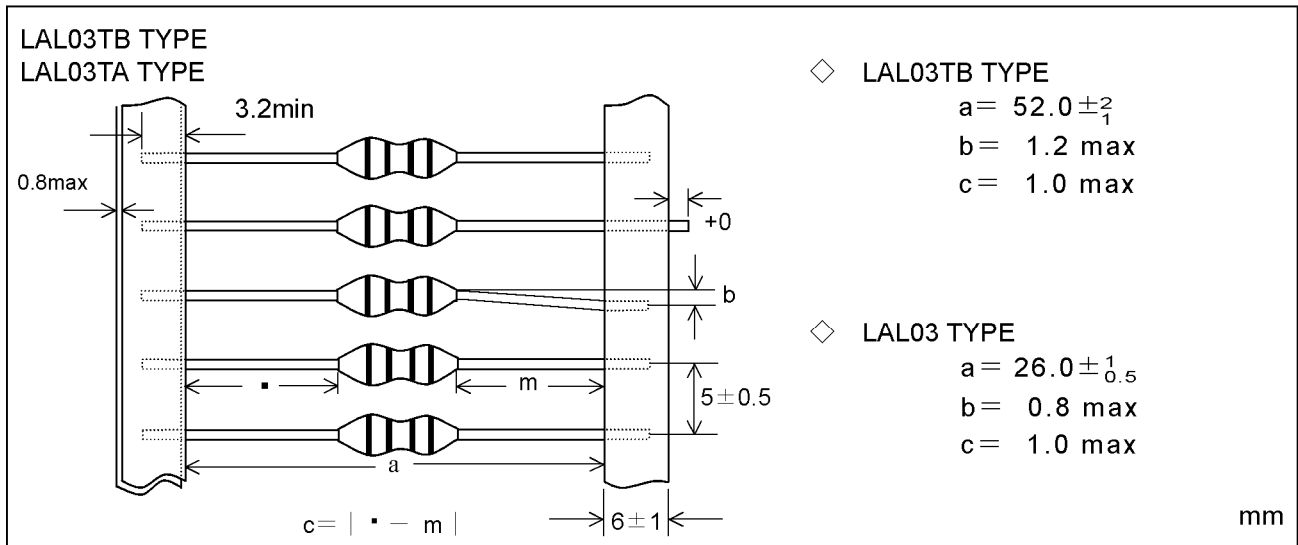
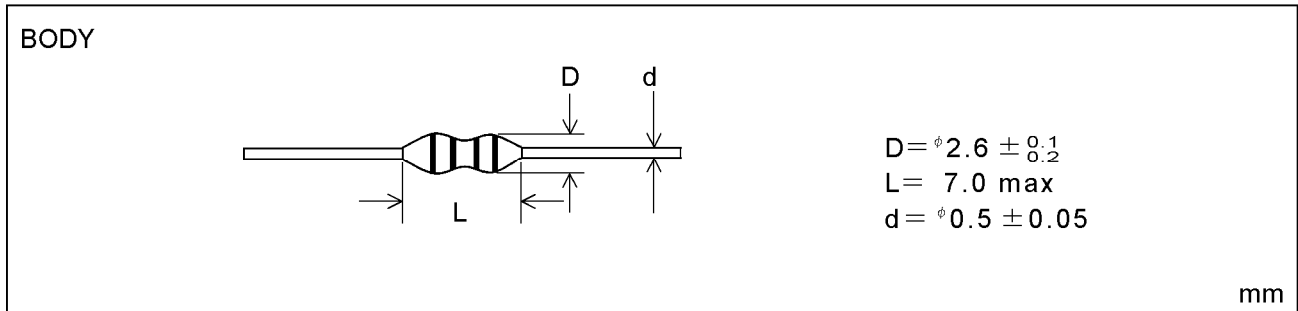
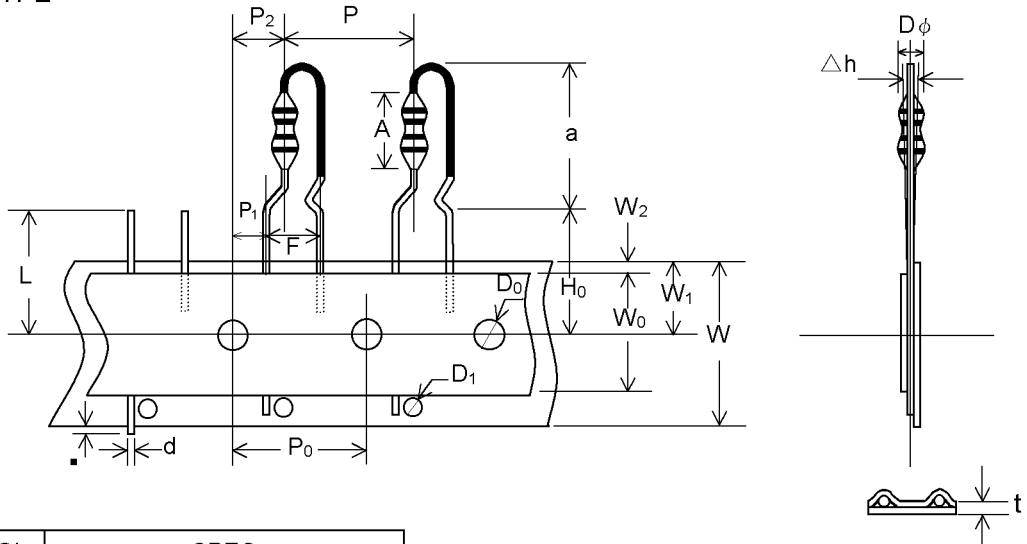

Table 2

AXIAL LEAD INDUCTORS

(4/7)

LAL03VB TYPE



SYMBOL	SPEC
P	12.7 ± 1.0
P ₀	12.7 ± 0.3
P ₁	3.85 ± 0.7
P ₂	6.35 ± 1.0
d	φ 0.6 ± 0.05
F	5.0 ± 1.0
Δh	0 ± 2.0
W	18.0 ^{+1.0} / _{-0.5}
W ₀	12.5 min
W ₁	9.0 ^{+0.75} / _{-0.50}
W ₂	3.0 max
H ₀	16.0 ± 0.5
▪	1.0 max
D ₀	φ 4.0 ± 0.2
D ₁	φ 3.5 max
t	0.7 ± 0.2
L	11.0 max
a	12.5 max
A	7.0 max
Dφ	φ 2.7 max

PACKING

- ◇ AMMO PACKING
LAL03VB TYPE

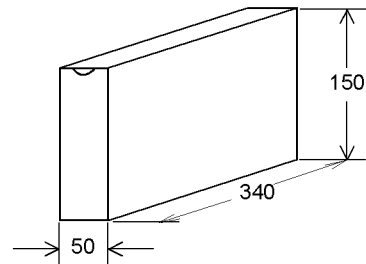

STANDAARD QUANTITY : 2 000 pcs.

- ◇ BAGGED PACKING
LAL03VS TYPE

STANDAARD QUANTITY : 500 pcs.

LAL03VS TYPE

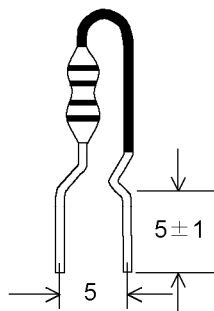

mm

(5 / 7)	Table 3
	AXIAL LEAD INDUCTORS

	Item	Standards	Test methods
	Operating Temperature Range	-25 °C to +85 °C	
ELECTRICAL CHARACTERISTIC	DC superposition characteristic	△L/L→Within -10 %	The inductance at the time of applying the rated current is measured by LCR meter, and the result is compared with initial value.
	Temperature rise	Within 20 °C	After applying the rated current for 30 minutes, the rise in temperature is measured by the resistance substitution method.
	Temperature characteristic	△L/L→Within ±5 %	To be measured in the range of -25 °C to +85 °C. The value at 20 °C is used as the standard.
	Over current test	No emission of smoke nor firing.	A current in the size of twice as much as the rated current is applied for 5 minutes.
	Solder heat resistance	The appearance should not be very abnormal.	Immersed in H63A solder at 270±5 °C for 5±0.5 seconds. P:t=1.6 mm
	Solderability	3/4 or greater part in the circumference direction should be soldered.	Immersed in H63A solder at 230±5 °C for 2±0.5 seconds.
MECHANICAL CHARACTERISTICS	Tensile strength test	Should not be disconnected.	One side of the lead is held firmly and a 25 N load is gradually applied to the other side in the axial direction for 5 seconds.
	Bending test	Should not be disconnected.	90° bending and straightening movement are given twice applying a load of 2.5 N.
	Body strength test	Should not be broken.	50 N load is applied for 10 seconds.
	Falling test	The appearance should not be very abnormal.	To drop from a height of 1 m onto a concrete or polyvinyl tile floor, 10 times.
	Vibration test	△L/L → Within ±5 % Q → 30 or greater	2 hours each in the X, Y and Z directions with the sample attached to PC board. Sweeping for one minute in the range of 10-55-10 Hz and 1.5 mm amplitude.
ENVIRONMENT TEST	Humidity test	△L/L → Within ±10 % Q → 30 or greater	40±2 °C, 90~95 % relative humidity, 1 000 hours.
	Humidity loading test	△L/L → Within ±10 % Q → 30 or greater	Applying the rated current for 1 000 hours, under the atmosphere of 40±2 °C, 90~95 % RH.
	Low temperature test	△L/L → Within ±10 % Q → 30 or greater	-25±2 °C, 1 000 hours.
	Temperature cycle	△L/L → Within ±10 % Q → 30 or greater	-25 °C to +85 °C, to be retained for 30 minutes, 5 cycles.
	High temperature loading test	△L/L → Within ±10 % Q → 30 or greater	Applying the rated current for 1 000 hours at 85±2 °C.

* Unless specified, all samples must be left at the normal temperature for one hour or longer and measured within 2 hours.

(6 / 7)	Specifications	
	AXIAL LEAD INDUCTORS	

Table 4
Structural Diagram

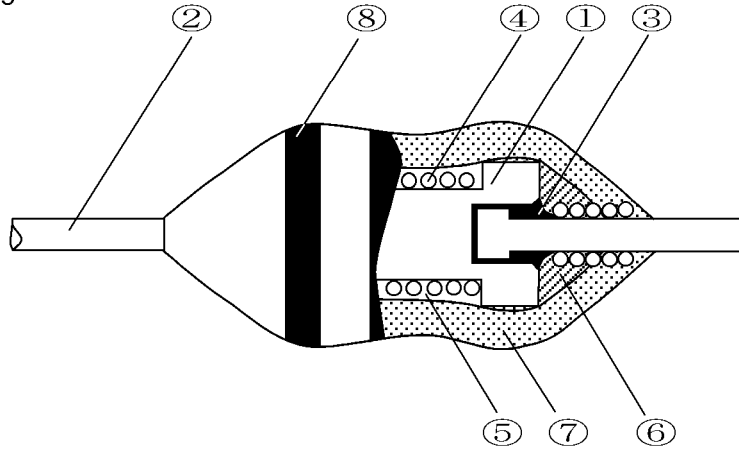

- | | | |
|---|---------------------|--|
| ① | Ferrite Core | Material A: $0.22 \mu H \sim 10 \mu H$
Material B: $12 \mu H \sim 1\,000 \mu H$ |
| ② | Lead wire | Solder coating (Lead plating composition : Sn or Sn / Cu
Joint solder : Sn / Ag / Cu
or lead plating and joint solder : Sn / Pb) |
| ③ | Adhesive | Epoxy resin |
| ④ | Coil material | Polyurethane-copper wire |
| ⑤ | Under-coating resin | Butadiene resin |
| ⑥ | Side-coating resin | Epoxy resin |
| ⑦ | Over-coating resin | Epoxy resin |
| ⑧ | Color code | Melamine resin |

Table 5
Color Code

Color Code	1st Color belt (1st numeric)	2nd Color belt (2nd numeric)	3rd Color belt (Multiplier)	4th Color belt (Tolerance)
Black	0	0	$\times 1$	$\pm 20 \%$
Brown	1	1	$\times 10$	_____
Red	2	2	$\times 10^2$	_____
Orange	3	3	_____	_____
Yellow	4	4	_____	_____
Green	5	5	_____	_____
Blue	6	6	_____	_____
Violet	7	7	_____	_____
Gray	8	8	_____	_____
White	9	9	_____	_____
Gold	_____	_____	$\times 10^{-1}$	$\pm 5 \%$
Silver	_____	_____	$\times 10^{-2}$	$\pm 10 \%$

Guarantee · Precautions

(7 / 7)

1. Handling

- Keep the inductors away from all magnets and magnetic objects.
- Please don't wash with supersonic waves.

2. Storage

To maintain the solderability of terminal electrodes and to keep the packing material in good condition, temperature and humidity in the storage area should be controlled..

Recommended conditions

Ambient temperature	Below 40 °C
Humidity	Below 70 % RH

The ambient temperature must be kept below 30 °C. Even under ideal storage conditions, solderability of inductor's electrodes may decrease as time passes. For this reason, inductors should be used within one year from the time of delivery.

3. Regulations

- No ozone-depleting substances, which are defined as Class- I and Class- II in the US Federal Clean Air Act, are used in the production processes, nor contained in the product.
- No flame-resistant bromides are used.
- The product and the specifications described above are not included in the list of export regulations in Japan and USA.

4. Production Sites

- KOREA TAIYO YUDEN CO.,LTD. 【KOREA】
BG-4 Masan Free Export Zone 974-13 Yang Duck Dong Masan Korea
- TAIYO YUDEN (SINGAPORE) PTE. LTD. 【SINGAPORE】
19 Joo Koon Circlr, Jurong Town, Singapore 629051
- TAIYO YUDEN (SARAWAK) SDN. BHD. 【MALAYSIA】
Lot 977, Block 12, Sama Jaya Free Industrial Zone 93450 Kuching Sarawak Malaysia

5. Guarantee

The operating conditions for the guarantee of this product are as shown in the drawing for specification.

Please note that Taiyo Yuden Co., Ltd. shall not be responsible for a failure and/or abnormality which is caused by use under conditions other than the aforesaid operating conditions.

6. Precautions

- The products described in this specification are intended for use in general electronic equipment, (office supply equipment, telecommunications systems, measuring equipment, and household equipment). They are not intended for use in mission-critical equipment or systems requiring special quality and high reliability (traffic systems, safety equipment, aerospace systems, nuclear control systems and medical equipment including life-support systems,) where product failure might result in loss of life, injury or damage. For such uses, contact TAIYO YUDEN Sales Department in advance.
- At using TAIYO YUDEN products of this specification and in case of using the lead free soldering, We request to use them after confirming of adhesion, temperature of resistance to soldering heat, solderability and soldering shape situation etc sufficiently.