

THIS DRAWING IS UNPUBLISHED. RELEASED FOR PUBLICATION  
 © COPYRIGHT - By - ALL RIGHTS RESERVED.

LOC		DIST		REVISIONS			
P	LTR	DESCRIPTION	DATE	DWN	APVD		
AD	39						
	E3	REVISED PER ECO-11-004917	11MAR11	RK	HMR		

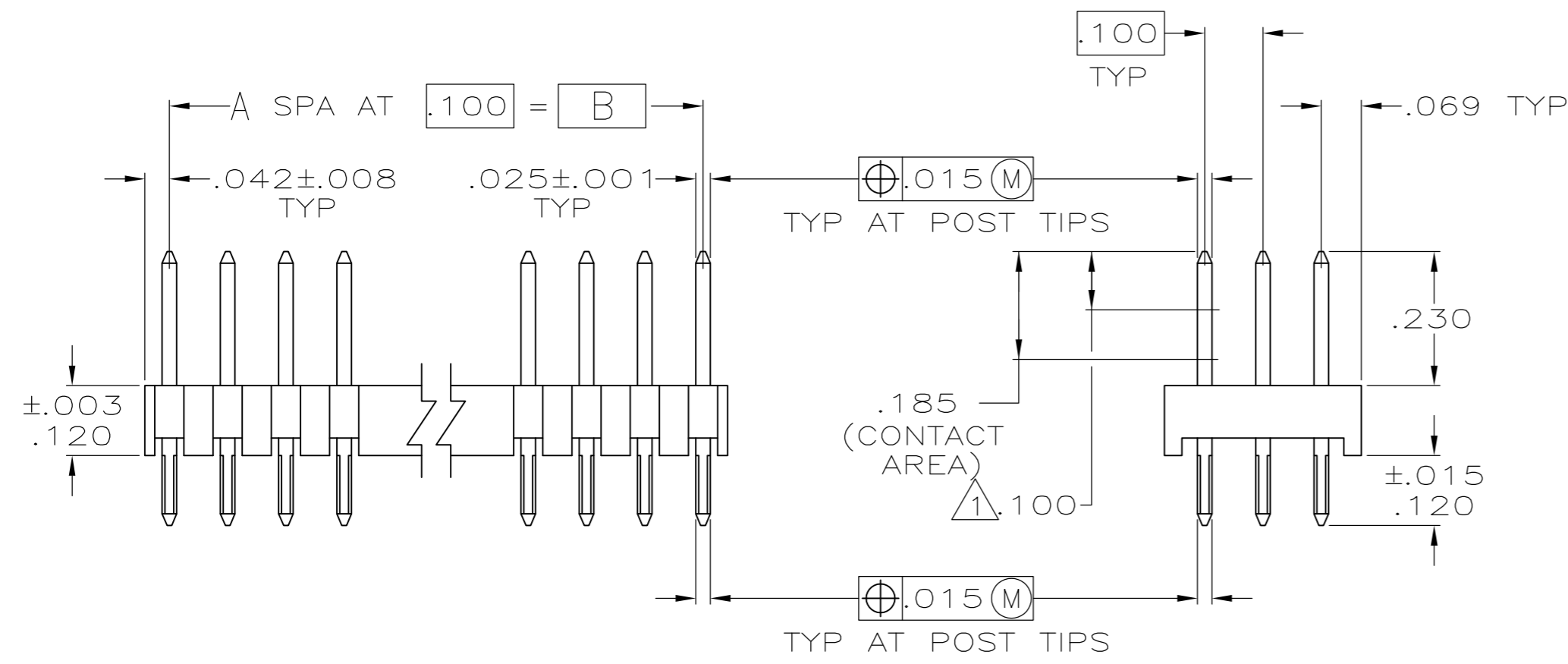
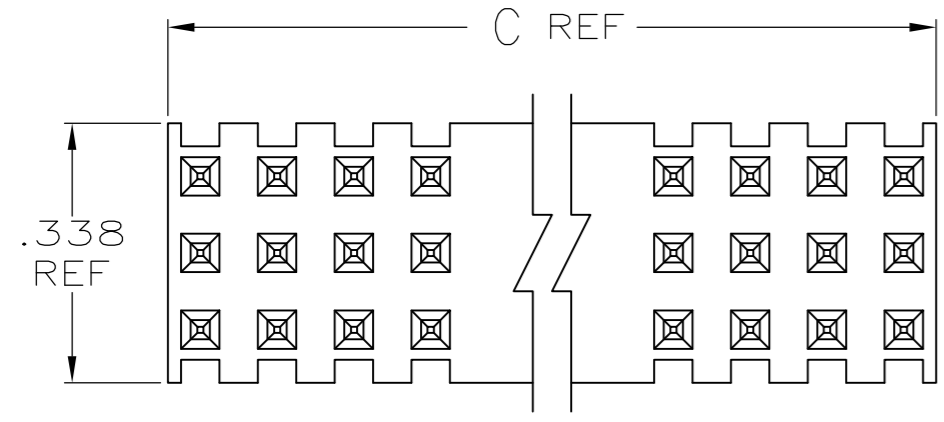

- 1 POINT OF MEASUREMENT FOR PLATING THICKNESS
- 2 TRUE POSITION TOLERANCE OF THE POST TIPS APPLIES WHEN THE HEADERS ARE HELD FLAT AGAINST THE PRINTED CIRCUIT BOARDS
- 3 .000030 GOLD ON THE CONTACT AREA, .000100-.000200 BRIGHT TIN-LEAD ON THE SOLDER TAIL ALL OVER .000050 NICKEL
- 4 .000030 GOLD ON THE CONTACT AREA, .000100-.000200 MATTE TIN ON THE SOLDER TAIL ALL OVER .000050 NICKEL
- 5 HOUSING- FLAME RETARDANT THERMOPLASTIC, COLOR-BLACK POSTS-PHOS BRONZE
- 6 OBSOLETE PARTS: OBSOLETE CIS STREAMLINING PER D.RENAUD/D.SINISI

FINISH	C	B	A	NO OF POS	ASSEMBLY PART NUMBER
	3.984	3.900	39	120	8-103817-8
	3.184	3.100	31	96	6-103817-0
	2.384	2.300	23	72	6-103817-2
	2.284	2.200	22	69	6-103817-1
	1.984	1.900	19	60	6-103817-8
	1.484	1.400	14	45	6-103817-3
	1.384	1.300	13	42	6-103817-2
	1.084	1.000	10	33	6-103817-9
	.984	.900	9	30	5-103817-8
	.884	.800	8	27	6-103817-7
	.784	.700	7	24	5-103817-6
	.684	.600	6	21	6-103817-5
	.584	.500	5	18	6-103817-4
	.484	.400	4	15	6-103817-3
	.384	.300	3	12	5-103817-2
	.284	.200	2	9	6-103817-1

FINISH	C	B	A	NO OF POS	ASSEMBLY PART NUMBER
	3.984	3.900	39	120	3-103817-8
	3.884	3.800	38	117	3-103817-7
	3.784	3.700	37	114	3-103817-6
	3.684	3.600	36	111	3-103817-5
	3.584	3.500	35	108	3-103817-4
	3.484	3.400	34	105	3-103817-3
	3.384	3.300	33	102	3-103817-2
	3.284	3.200	32	99	3-103817-1
	3.184	3.100	31	96	3-103817-0
	3.084	3.000	30	93	2-103817-9
	2.984	2.900	29	90	2-103817-8
	2.884	2.800	28	87	2-103817-7
	2.784	2.700	27	84	2-103817-6
	2.684	2.600	26	81	2-103817-5
	2.584	2.500	25	78	2-103817-4
	2.484	2.400	24	75	2-103817-3
	2.384	2.300	23	72	2-103817-2
	2.284	2.200	22	69	2-103817-1
	2.184	2.100	21	66	2-103817-0
	2.084	2.000	20	63	1-103817-9
	1.984	1.900	19	60	1-103817-8
	1.884	1.800	18	57	1-103817-7
	1.784	1.700	17	54	1-103817-6
	1.684	1.600	16	51	1-103817-5
	1.584	1.500	15	48	1-103817-4
	1.484	1.400	14	45	1-103817-3
	1.384	1.300	13	42	1-103817-2
	1.284	1.200	12	39	1-103817-1
	1.184	1.100	11	36	1-103817-0
	1.084	1.000	10	33	1-103817-9
	.984	.900	9	30	1-103817-8
	.884	.800	8	27	1-103817-7
	.784	.700	7	24	103817-6
	.684	.600	6	21	103817-5
	.584	.500	5	18	103817-4
	.484	.400	4	15	1-103817-3
	.384	.300	3	12	103817-2
	.284	.200	2	9	103817-1

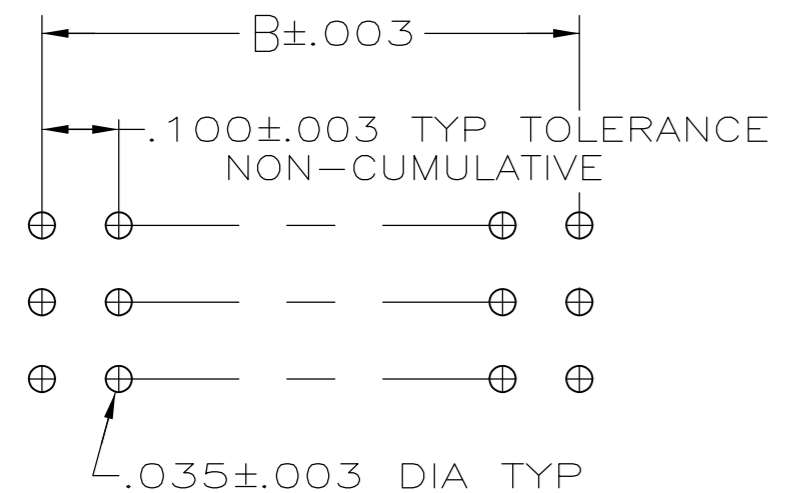

RECOMMENDED HOLE LAYOUT

THIS DRAWING IS A CONTROLLED DOCUMENT.

DIMENSIONS: INCHES	TOLERANCES UNLESS OTHERWISE SPECIFIED:	DWN K HELM 1-22-91	TE Connectivity
		CHK R. FEIDT 1-22-91	
		APVD -	ASSEMBLY, MOD II, HEADER, TRIPLE ROW, .100X.100X.100
		PRODUCT SPEC -	SIZE CAGE CODE DRAWING NO RESTRICTED TO
		APPLICATION SPEC -	A2 00779 C=103817
MATERIAL 5	FINISH SEE TABLE	WEIGHT -	SCALE 1:1 SHEET 1 OF 1 REV E3
		CUSTOMER DRAWING	