

THIS DRAWING IS UNPUBLISHED. RELEASED FOR PUBLICATION  
 © COPYRIGHT - A1 ALL RIGHTS RESERVED.

LOC		DIST		REVISIONS			
P	LTR	DESCRIPTION		DATE	DWN	APVD	
	A1	REVISED PER ECO-11-004820		11MAR11	RK	HMR	

- 1 ALL DIMENSIONS ARE IN MM.
- 2 RECOMMENDED PC-BOARD HOLES DIAMETER:  $\phi 1.20$  to  $\phi 1.40$ .
- 3 BUCHANAN LOGO TO APPEAR ON HOUSING LOCATION OPTIONAL WHERE SPACE PERMITS.
- 4 NON CUMULATIVE
- 5 PARTS TO BE MARKED WITH PERMANENT BLACK MARKING.
- 6 POSITIONS 1-2, 3-4, AND 7-8 COMMONED. POSITIONS 9-10 NOT LOADED.
- 7 POSITIONS 1-2, 7-8, AND 9-10 COMMONED.
- 8 PRELIMINARY PART NUMBER.

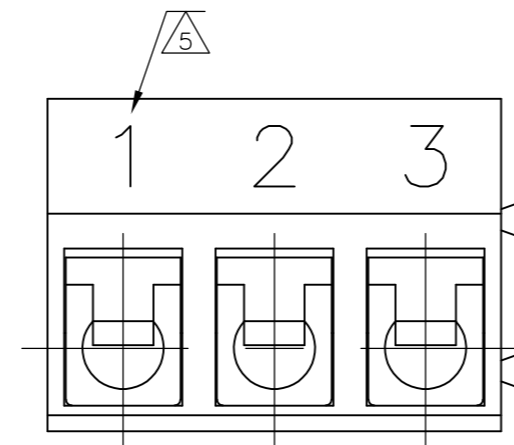
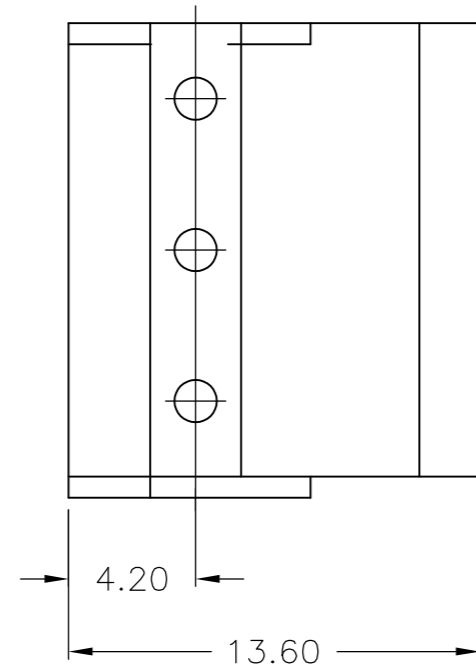
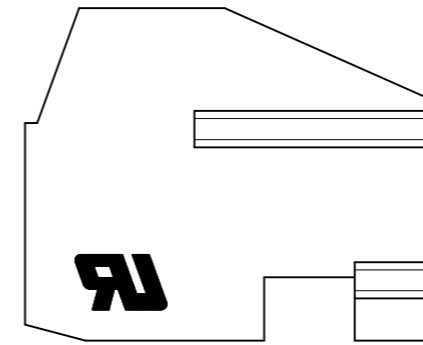
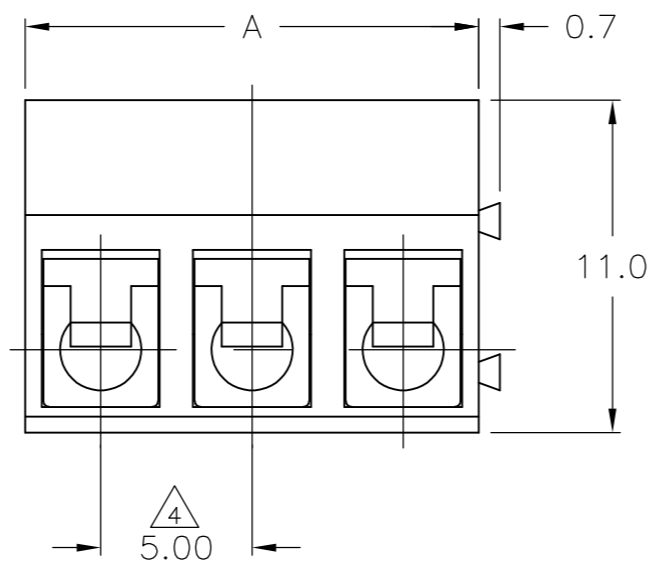
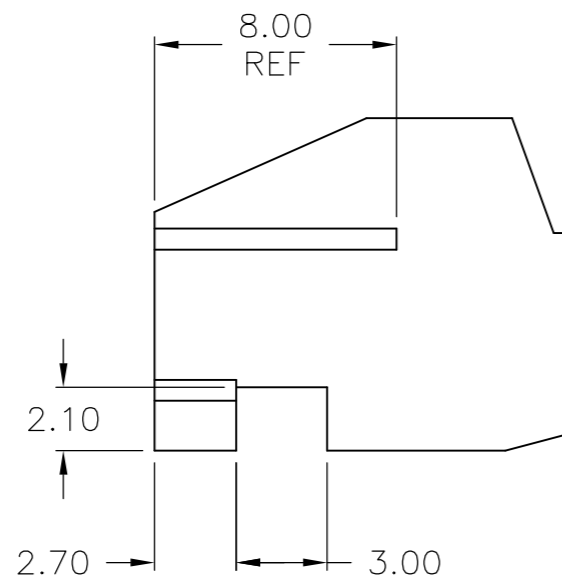
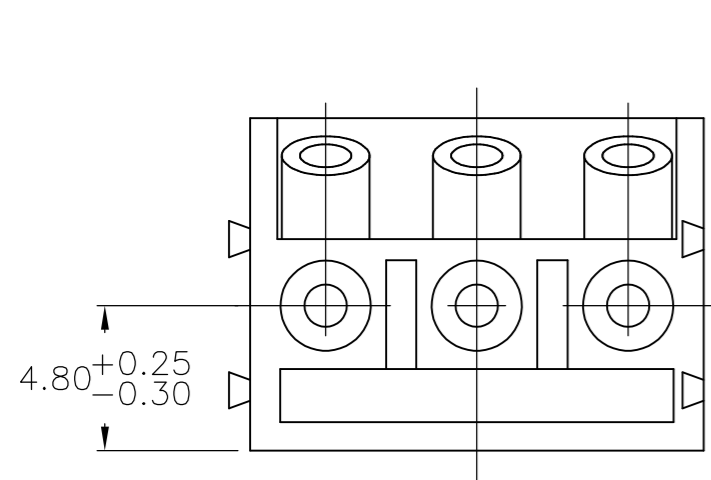
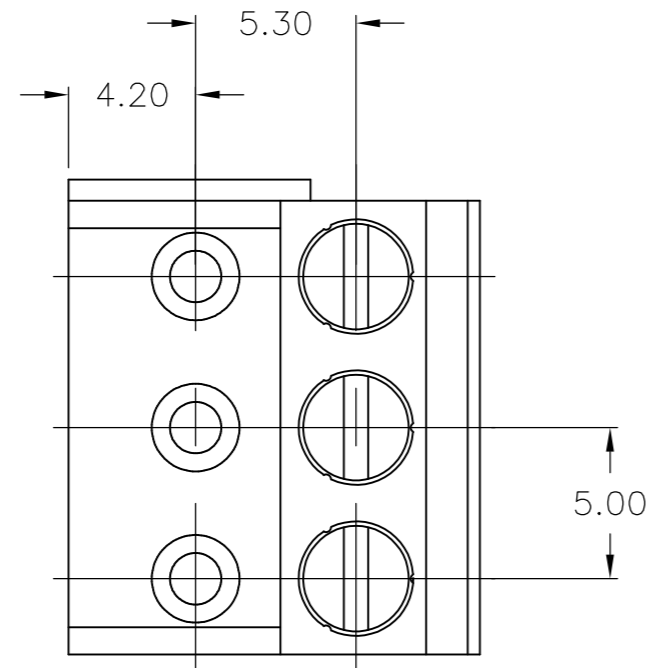

DETAIL C

NO	DESCRIPTION	FINISH	QTY	UNIT	PART NUMBER
7-8	DETAIL F	TIN	50.00	10	5-1776263-2
6-8	DETAIL E	TIN	50.00	10	5-1776263-1
8	DETAIL D	TIN	45.00	9	5-1776263-0
8	-	0.254um GOLD	10.00	2	4-1776263-9
8	DETAIL C	TIN	15.00	3	4-1776263-8
8	-	GOLD FLASH	35.00	7	4-1776263-7
8	-	GOLD FLASH	30.00	6	4-1776263-6
8	-	GOLD FLASH	15.00	3	4-1776263-3
8	-	0.381um GOLD	35.00	7	3-1776263-7
8	-	0.381um GOLD	30.00	6	3-1776263-6
8	-	0.381um GOLD	15.00	3	3-1776263-3
OBSOLETE	-	TIN	120.00	24	2-1776263-4
OBSOLETE	-	TIN	115.00	23	2-1776263-3
OBSOLETE	-	TIN	110.00	22	2-1776263-2
OBSOLETE	-	TIN	105.00	21	2-1776263-1
OBSOLETE	-	TIN	100.00	20	2-1776263-0
OBSOLETE	-	TIN	95.00	19	1-1776263-9
OBSOLETE	-	TIN	90.00	18	1-1776263-8
OBSOLETE	-	TIN	85.00	17	1-1776263-7
OBSOLETE	-	TIN	80.00	16	1-1776263-6
OBSOLETE	-	TIN	75.00	15	1-1776263-5
OBSOLETE	-	TIN	70.00	14	1-1776263-4
OBSOLETE	-	TIN	65.00	13	1-1776263-3
-	-	TIN	60.00±0.40	12	1-1776263-2
-	-	TIN	55.00±0.40	11	1-1776263-1
-	-	TIN	50.00±0.35	10	1-1776263-0
-	-	TIN	45.00±0.30	9	1776263-9
-	-	TIN	40.00±0.30	8	1776263-8
-	-	TIN	35.00±0.25	7	1776263-7
-	-	TIN	30.00±0.25	6	1776263-6
-	-	TIN	25.00±0.25	5	1776263-5
-	-	TIN	20.00±0.25	4	1776263-4
-	-	TIN	15.00±0.25	3	1776263-3
-	-	TIN	10.00±0.25	2	1776263-2
DETAIL	FINISH	DIM A	NO OF POS	PART NUMBER	

THIS DRAWING IS A CONTROLLED DOCUMENT.

DWN	S SCHLEGEL	5/6/05
CHK	C RICHARD	5/6/05
APVD	C RICHARD	5/6/05
PRODUCT SPEC	-	-
APPLICATION SPEC	-	-
WEIGHT	-	-

TE Connectivity

TERMINAL BLOCK, 90 DEGREE, STACKING W/ WIRE PROTECTION, 5.0mm PITCH, HIGH TEMP

SCALE: A2 00779 C=1776263

CUSTOMER DRAWING SCALE 6:1 SHEET 1 OF 2 REV A1

THIS DRAWING IS UNPUBLISHED. RELEASED FOR PUBLICATION  
 © COPYRIGHT - By - ALL RIGHTS RESERVED.

LOC		DIST		REVISIONS			
P	LTR	DESCRIPTION		DATE	DWN	APVD	
-	-	SEE SHEET 1		-	-	-	

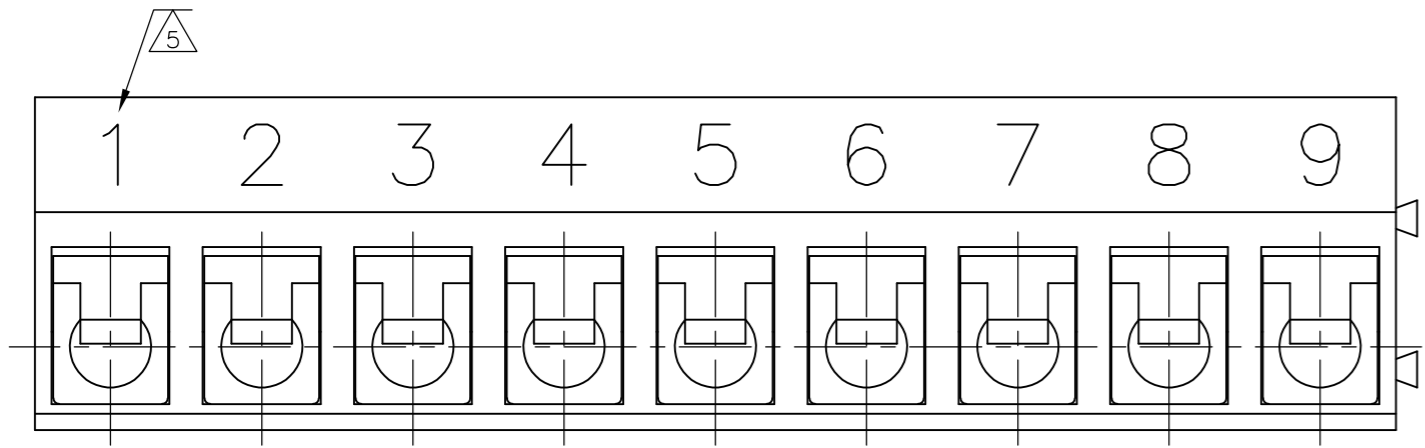

DETAIL D

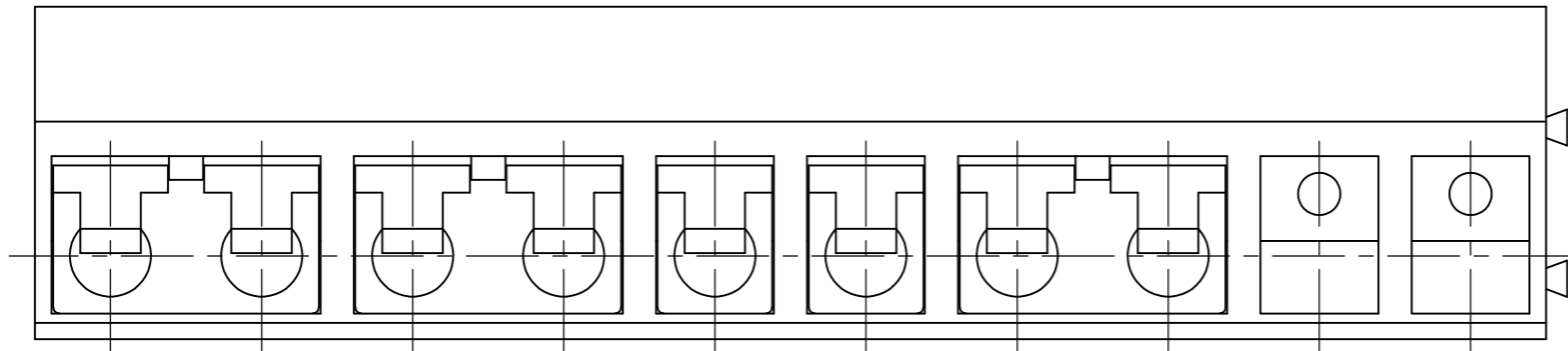

DETAIL E

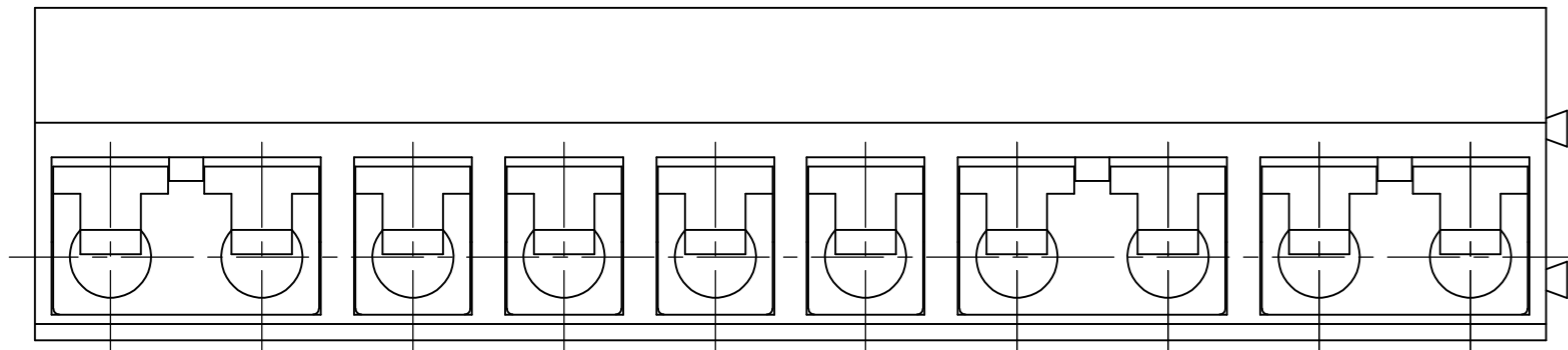

DETAIL F

1. Application and Features:

- 1-1. This terminal block is designed to plug onto loose pins or pin header strips.
- 1-2. With wire guard for wire protection so that the screw doesn't press directly on the wire.
- 1-3. Easy handling due to the pluggable system horizontally or vertically.

2. Technical Data:

- 2-1. Material(blue)
- 2-1-1. Housing: Nylon or Polyester.
- 2-1-2. Metal Housing: Brass  
Finish: see table.
- 2-1-3. Wire Guard: Phosphor Bronze
- 2-1-4. Screw: Steel galvanized and chromated, M2.6.

2-3. Electrical:

- 2-3-1. Current rating: 10 amps/way max.
- 2-3-2. Contact resistance: 20mohm (MAX).
- 2-3-3. Insulation resistance: 2000Mohm /500V.
- 2-3-4. Withstanding voltage: 1500 VAC/min, test time= 60sec/1pc.
- 2-3-5. Operation voltage: 300 VAC.
- 2-3-6. Wire Range: 16-24 AWG.

2.4 Mechanical:

- 2-4-1. Torque: 3 in-lb.
- 2-4-2. Contact retention Force: 0.2Kg/cm (min).
- 2-4-3. Operating temperature: -40°C to +105°C.
- 2-4-4. Solderability: 95% coverage (min).  
test temperature=230°C±10°C  
test time= 3sec±0.5sec.

1776263

THIS DRAWING IS A CONTROLLED DOCUMENT.		DWN	S SCHLEGEL	5/6/05	 TE Connectivity	
DIMENSIONS:		CHK	C RICHARD	5/6/05		
mm		APVD	C RICHARD	5/6/05		
		PRODUCT SPEC				
TOLERANCES UNLESS OTHERWISE SPECIFIED:		APPLICATION SPEC				
0 PLC ± -		WEIGHT				
1 PLC ± 0.3						
2 PLC ± 0.25						
3 PLC ± -						
4 PLC ± -						
ANGLES ± -						
FINISH						
-						
		SIZE	A2	CAGE CODE	00779	
		DRAWING NO	C=1776263		RESTRICTED TO	
		CUSTOMER DRAWING			SCALE	6:1
		SHEET	2 OF 2		REV	A1