

THIS DRAWING IS UNPUBLISHED. RELEASED FOR PUBLICATION, 19 .
 © COPYRIGHT 19 BY AMP INCORPORATED. ALL INTERNATIONAL RIGHTS RESERVED.

LOC	DIST	P	F	REVISIONS				
AF	50			ZONE	LTR	DESCRIPTION	DATE	APPD
					0	DRAWN	8/16/95	JR/PD

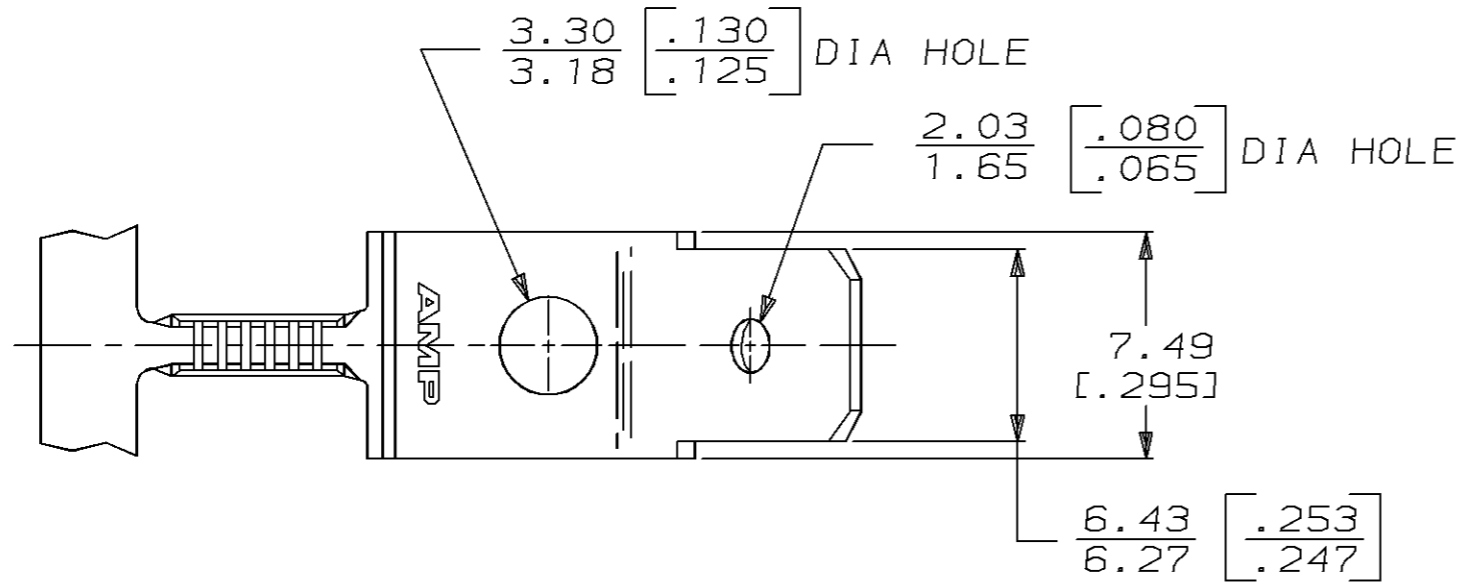

- 1 CONTINUOUS STRIP ON REELS.
- 2 TAB DIMENSIONS ARE IN ACCORDANCE WITH NEMA DC-2 STD.

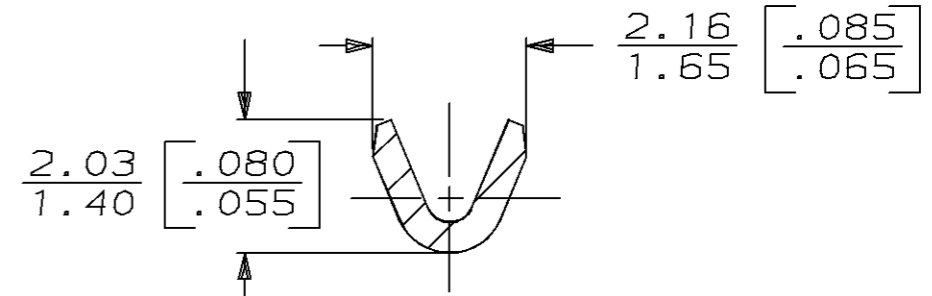
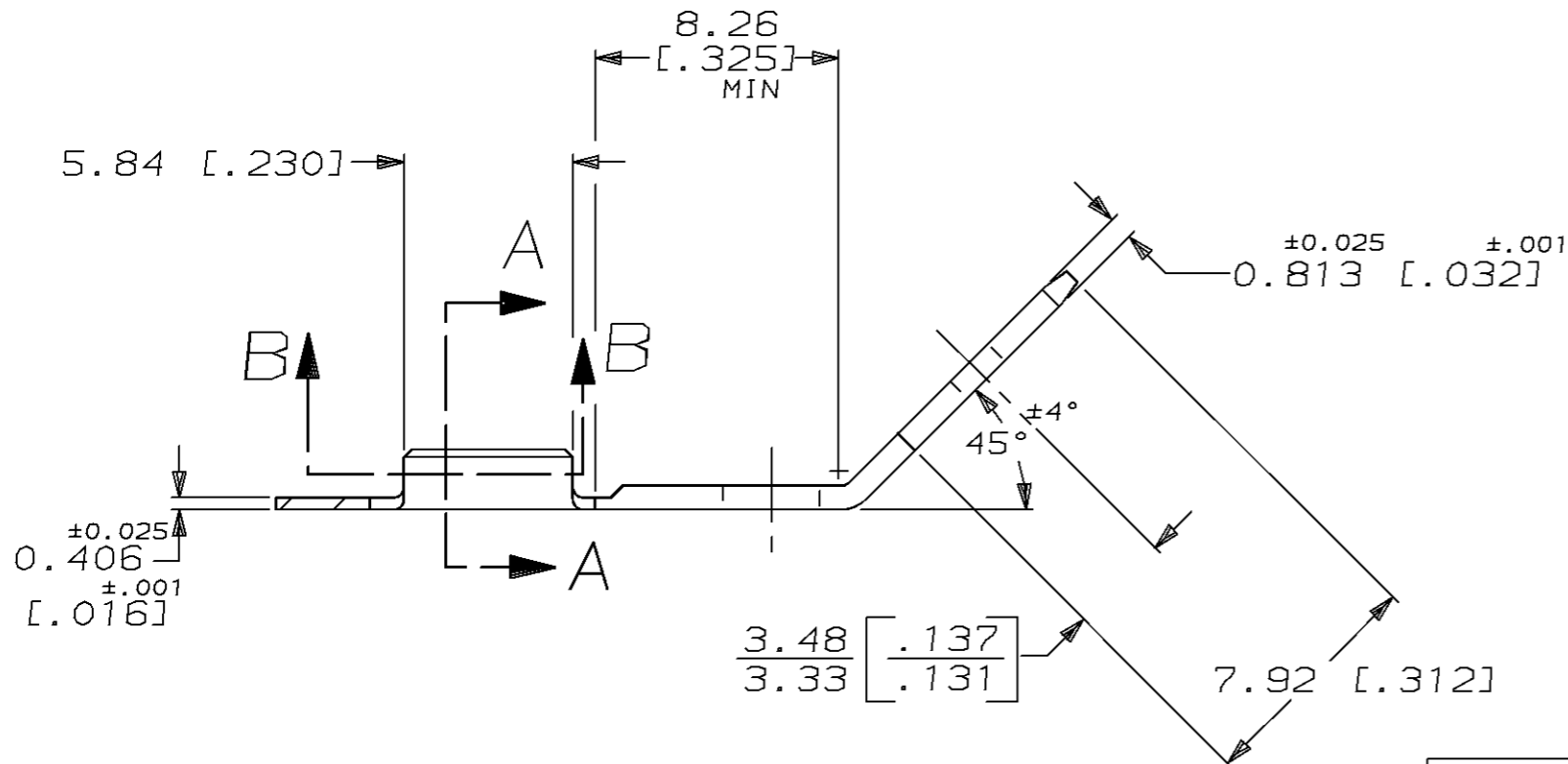

200-566 CMA	63611-1	
WIRE RANGE	PART NO	
AMP AMP Incorporated Harrisburg, PA 17105-3608		
NAME TAB, FASTON™ AMPLIVAR, 6.35 [.250] SERIES		
SIZE	CAGE CODE	DRAWING NO
B	00779	63611
SCALE	4:1	SHEET
		1 OF 1

DO NOT SCALE PRINT. UNLESS SPECIFIED DIMENSIONS IN mm [INCHES] TOLERANCES ON: 2 PLC DEC ± 0.25 [.010] 3 PLC DEC ± - ANGLES ± -	DR 8/16/95 JR RUTH
	CHK 8/16/95 MS FEHER
	APPD 8/16/95 P DESANTIS
	APPD 8/16/95 D REINER
MATERIAL PREMILLED #2H BRASS	PRODUCT SPEC -
FINISH TIN 0.002032 [.000080] MIN WITH VARNISH RESIST	APPLICATION SPEC - WEIGHT -