

THIS DRAWING IS UNPUBLISHED. RELEASED FOR PUBLICATION ,19 .
 © COPYRIGHT 19 BY AMP INCORPORATED. ALL RIGHTS RESERVED.

| LOC | DIST | REVISIONS | | | | | |
|-----|------|-----------|-----|--------------------------|---------|-----|------|
| | | P | LTR | DESCRIPTION | DATE | DWN | APVD |
| G | 14 | | C | REVISED PER 0L20-0224-97 | 150CT97 | DKS | MJS |

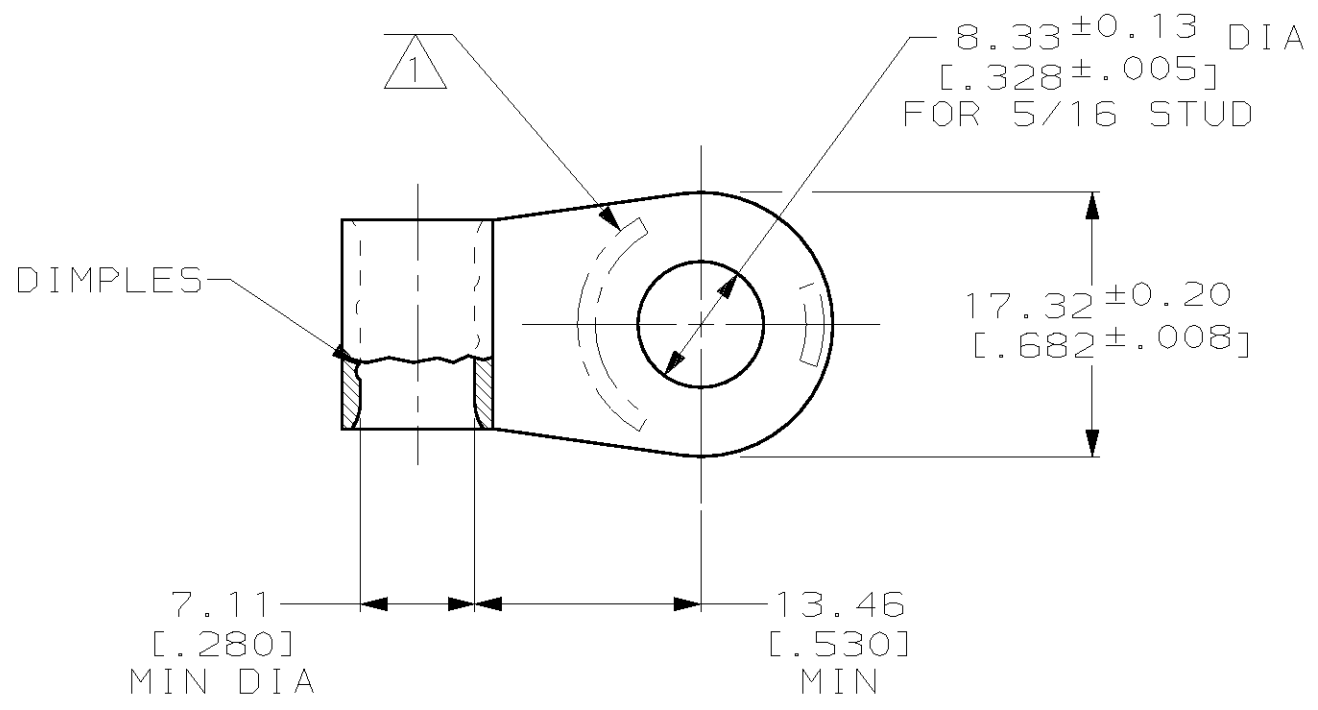

| | |
|----------------------------|-------------------------------|
| AMP WIRE RANGE | UL E13288 Listed |
| 4 AWG SOLID OR STRANDED | 4 AWG STRANDED |
| SR LR7189 Certified | MILITARY P/N AND CLASS |
| 4 AWG SOLID OR STRANDED | NOT APPLICABLE |

① STAMP AMP 4W* 40-50 APPROX AS SHOWN

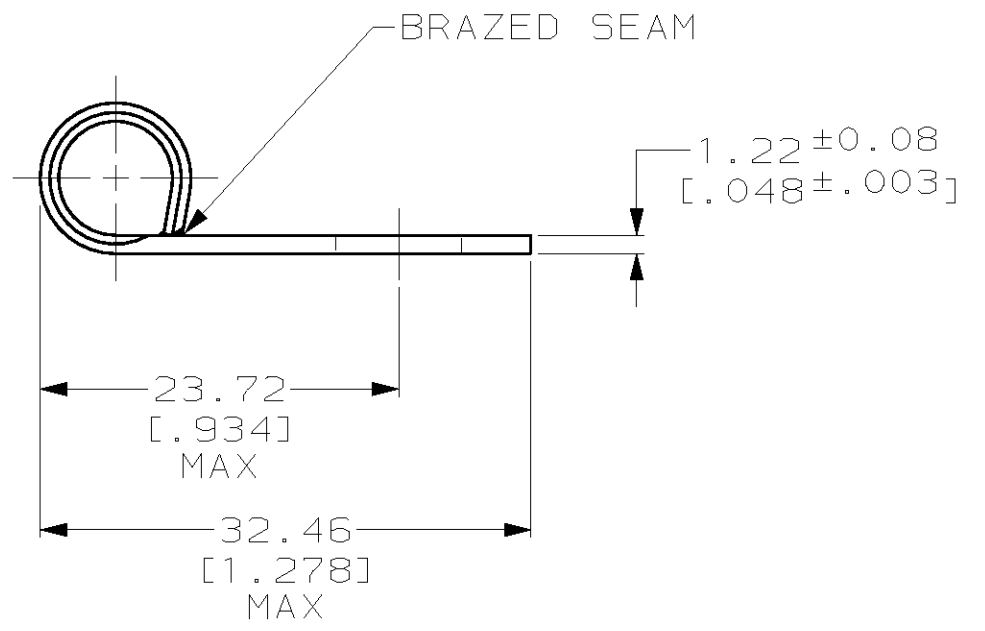

321060
AMP
PART NUMBER

AMP INCORPORATED CUSTOMER SERVICE SYSTEMS

| | | |
|--|--|--|
| FOR ADDITIONAL PRODUCT INFORMATION OR COPIES OF DRAWINGS AND TECHNICAL DOCUMENTS | PRODUCT INFORMATION CENTER 1-800-522-6752 | RECOMMENDED OPERATING TEMPERATURE: 170°C MAX |
| FOR APPLICATION TOOLING INFORMATION | TOOLING ASSISTANCE CENTER 1-800-722-1111 | VOLTAGE RATING: NOT APPLICABLE |
| FOR ORDER ENTRY | 1-800-526-5142 | WIRE CROSS SECTIONAL AREA RANGE: 16.8-26.7mm ² [33,100-52,600] CIR MILS SOLID OR STRANDED |

| | |
|---|--|
| THIS DRAWING IS A CONTROLLED DOCUMENT FOR AMP INCORPORATED. IT IS SUBJECT TO CHANGE AND THE CONTROLLING ENGINEERING ORGANIZATION SHOULD BE CONTACTED FOR THE LATEST REVISION. | |
| DIMENSIONS: mm [INCHES] | TOLERANCES UNLESS OTHERWISE SPECIFIED: |
| | 0 PLC ±- |
| | 1 PLC ±- |
| | 2 PLC ±0.20 [.008] |
| | 3 PLC ±- |
| | 4 PLC ±- |
| | ANGLES ±- |
| MATERIAL COPPER PER ASTM B-152 ANNEALED | FINISH TIN PLATE 0.00254 [.000100] MIN THK PER ASTM B-545 |

| | |
|--------------------|---------|
| DWN DK SCHRUM | 150CT97 |
| CHK MJ SPICER | 150CT97 |
| APVD JL MECKLEY | 150CT97 |
| PRODUCT SPEC | - |
| APPLICATION SPEC | - |
| WEIGHT | - |
| CUSTOMER DRAWING | |

| | |
|--|--------------------|
| AMP AMP Incorporated Harrisburg, PA 17105-3608 | |
| NAME TERMINAL, RING TONGUE, FLAG, SOLISTRAND™ | |
| SIZE A3 | CAGE CODE 00779 |
| DRAWING NO C-321060 | |
| SCALE 2:1 | SHEET 1 OF 1 |
| REV C | |