

PRODUCT NUMBER
SEE TABLE

1 | 2 | 3 | 4 | 5 | 6

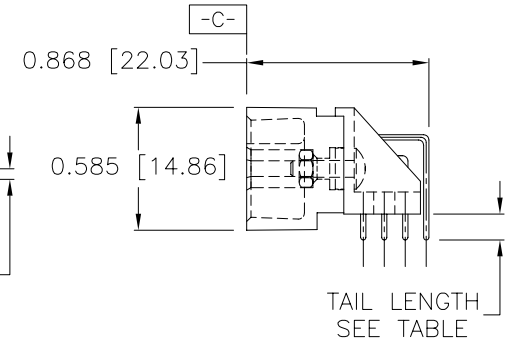
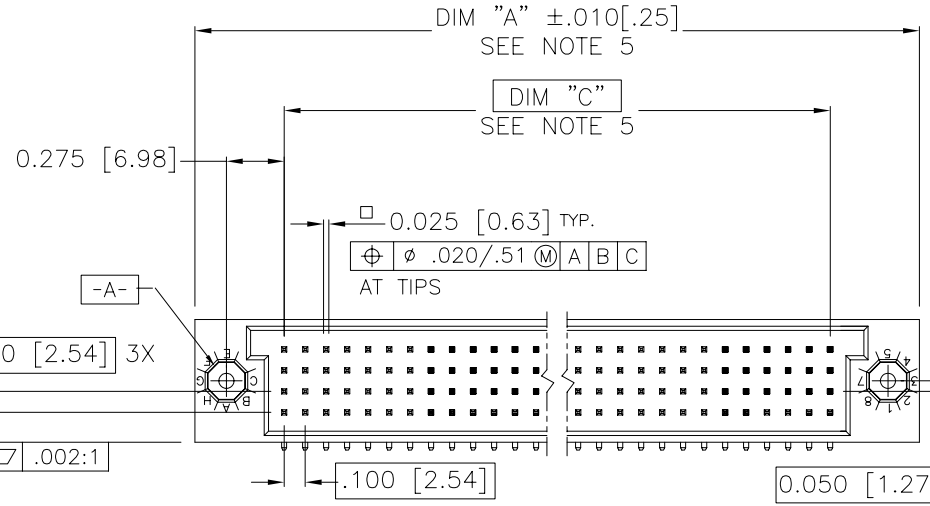
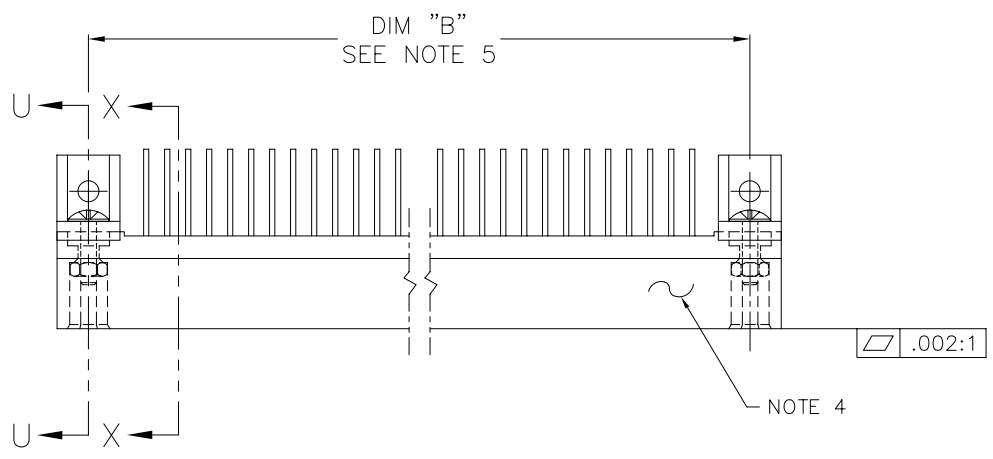

mat'l. code SEE NOTE 3		surface ISO 1302 <input checked="" type="checkbox"/>		tolerance ISO 406 ISO 1101		projection 		product family HPC	
ltr J		ecm no v90523		date HTB 3/1/99		tolerances unless otherwise specified		title	
K		v00262		JWS 1/26/00		angles linear		INCH/MM	
L		v05-0740		DAI 10/7/05		.XX \pm .01/.3 .XXX \pm .005/.13 .XXXX \pm .0020/.051		scale 1:1	
M		v05-1040		HTB 11/14/05		dr		dwg no	
N		M06-0283		MHT 7/27/06		enr		sheet 1 of 3 size	
						chr		50122	
						appd		A3	
						S.CLARK 6/5/91		type	
						S.CLARK 6/5/91		Product Customer Drawing	
sheet index		revision sheet		N 1		N 2		N 3	

form: A3 | 1 | 2 | 3 | 4 | 5 | 6

PRODUCT NO.
SEE TABLE

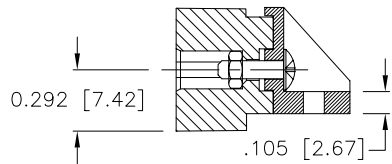

SECTION U-U

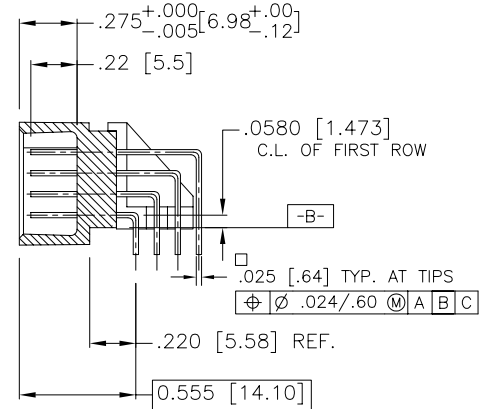

SECTION X-X

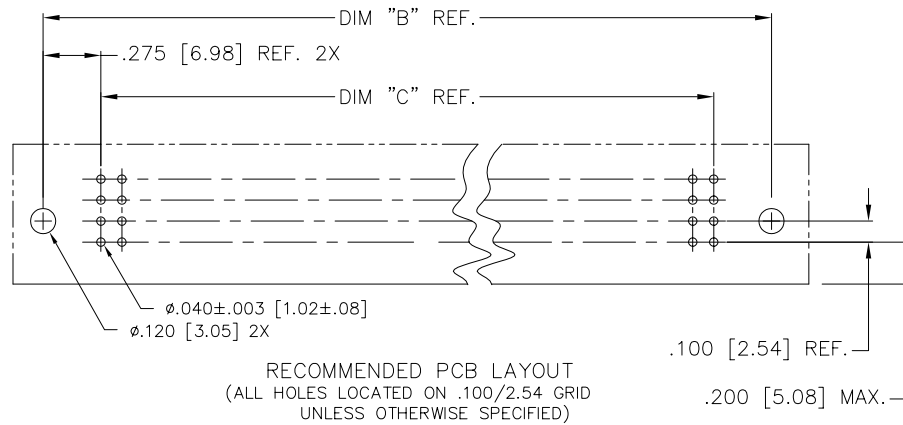

RECOMMENDED PCB LAYOUT
(ALL HOLES LOCATED ON .100/2.54 GRID
UNLESS OTHERWISE SPECIFIED)



Copyright FCI

mat'l. code SEE NOTE 3		surface ISO 1302 <input checked="" type="checkbox"/>	tolerance ISO 406 ISO 1101	projection 	product family HPC
ltr	ecn	no	dr	date	tolerances unless otherwise specified
N					angles linear .xx±.01/.3
					0°±2' .xxx±.005/.13
					.xxx±.0020/.051
			dr	D.SHEAFFER	6/5/91
			enr	S.CLARK	6/5/91
			chr	S.CLARK	6/5/91
			appd	S.CLARK	6/5/91
sheet	revision				
index	sheet				
				INCH/MM	
				scale 1:1	
				title 4 ROW R/A HEADER SOLDER TO BOARD, 0 G.P.	
				dwg no 50122	
				sheet 2 of 3 size A3	
				type Product Customer Drawing	

PRODUCT NUMBER	NUMBER OF POSITIONS SEE NOTE 2	TAIL LENGTH REF.	TERMINAL PLATING
50122 -1YYYH	YYY	.180/4.57	30μ"/.76μ GOLD
50122 -1YYYJ	YYY	.120/3.05	30μ"/.76μ GOLD
50122 -3YYYH	YYY	.180/4.57	50μ"/1.27μ GOLD
50122 -3YYYJ	YYY	.120/3.05	50μ"/1.27μ GOLD
50122 -5YYYH	YYY	.180/4.57	30μ"/.76μ GXT
50122 -5YYYHLF	YYY	.180/4.57	30μ"/.76μ GXT
50122 -5YYYJ	YYY	.120/3.05	30μ"/.76μ GXT
50122 -5YYYJLF	YYY	.120/3.05	30μ"/.76μ GXT

NOTES:

1. PRODUCT NUMBERING CODE:
 50122 - X YYY Z LF
 LEAD FREE (OPTIONAL)
 TAIL LENGTH SEE TABLE
 NO. OF POSITIONS SEE NOTE 2
 PLATING SEE TABLE
 BASE NUMBER

PRODUCT NUMBERING CODE FOR
 SELECT LOAD PART NUMBERS:
 50122 - XXYYY LF
 LEAD FREE (OPTIONAL)
 SEQUENCE NUMBER
 ALWAYS 'XX'
 BASE NUMBER

- 2. THIS PRODUCT IS CONFIGURED IN SIZES OF 6 THRU 100 COLUMNS IN INCREMENTS OF ONE. i.e.: 6,7,8,9,.....98,99,100.
- 3. HOUSING MATERIAL: GLASS AND MINERAL FILLED HIGH TEMP. THERMOPLASTIC. FLAME RETARDANT PER UL94V-0. COLOR: BLACK. PIN MATERIAL: PHOS. BRONZE
- 4. MANUFACTURE'S NAME, P/N, AND LOT CODE TO APPEAR ON THIS SURFACE PER BUS-12-108.
- 5. LENGTH FORMULAS:
 DIM "A" = .100/2.54 x NO. OF COLUMNS + .75/19.1
 DIM "B" = .100/2.54 x NO. OF COLUMNS + .450/11.43
 DIM "C" = .100/2.54 x NO. OF COLUMNS - .100/2.54

- 6. THIS PRODUCT (WITH "LF" SUFFIX) MEETS EUROPEAN UNION DIRECTIVES AND OTHER COUNTRY REGULATIONS AS DESCRIBED IN GS-22-008.
- 7. THIS HOUSING WILL WITHSTAND EXPOSURE TO 260° C PEAK TEMPERATURE FOR 10-30 SECONDS IN A CONVECTION, INFRA-RED OR VAPOR PHASE REFLOW OVEN.

mat'l. code SEE NOTE 3		surface ISO 1302 <input checked="" type="checkbox"/>	tolerance ISO 406 ISO 1101	projection 	product family HPC
ltr	ecn	no	dr	date	tolerances unless otherwise specified
N					angles linear .XX±.01/.3 .XXX±.005/.13 0'±2' .XXXX±.0020/.051
					INCH/MM scale 1:1
					title 4 ROW R/A HEADER SOLDER TO BOARD, 0 G.P.
					dwg no 50122
					sheet 3 of 3 size A3
					type Product Customer Drawing
sheet index	revision sheet				

Copyright FCJ
 FCJconnect.com