

**UNCONTROLLED DOCUMENT
WILL NOT BE UPDATED**

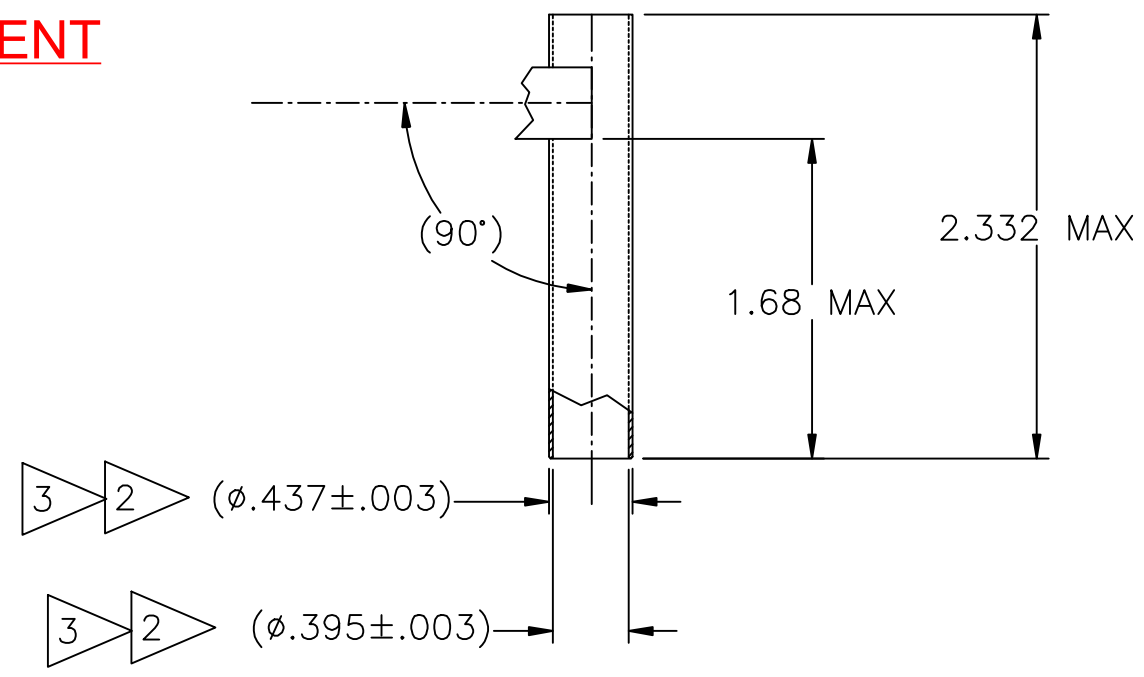

- 3. CHECK I.D. WITH GAGE PINS AND RING GAGE OVER TIP AND MINIMAL HAND PRESSURE APPLIED.
- 2. WITH TIPS CLOSED AROUND .390/.391 ϕ PIN, TIP SHALL ENTER A RING GAGE OF .442/.441 ϕ .

NOTES: 1. THIS IS AN AUTOCAD DRAWING DO NOT CHANGE MANUALLY.

THESE DRAWINGS, SPECIFICATIONS OR OTHER DATA ARE AND REMAIN THE PROPERTY OF ASTRO TOOL CORP. AND MUST BE RETURNED UPON REQUEST. THEY CONTAIN INFORMATION OWNED AND/OR DEVELOPED BY ASTRO AT ITS OWN PRIVATE EXPENSE AND MAY NOT BE USED, DUPLICATED OR DISCLOSED TO OTHERS, IN WHOLE OR IN PART FOR DESIGN, MANUFACTURE OR PROCUREMENT WITHOUT THE WRITTEN PERMISSION OF ASTRO TOOL CORP. EACH AND EVERY TIME.					SCALE:	UNLESS OTHERWISE SPECIFIED: DECIMALS: .XXX \pm .005 .XX \pm .010 .X \pm .030 ANGLES: \pm 1°	21615 S.W. TUALATIN VALLEY HWY., BEAVERTON OR 97006	CAGE 58164
					N.T.S.			DWN BY: DY0 DATE: 05-28-10 APPROVED:
REV.	DESCRIPTION	BY	DATE	APR.				
A	NEW RELEASE	DY0	05-28-10	MMK				