

Apr.1.2017 Copyright 2017 HIROSE ELECTRIC CO., LTD. All Rights Reserved.

COUNT	DESCRIPTION OF REVISIONS	BY	CHKD	DATE	COUNT	DESCRIPTION OF REVISIONS	BY	CHKD	DATE
△					△				
△					△				
△					△				

RECOMMENDED LAND PATTERN DIMENSION OF PCB (MOUNTING SIDE)

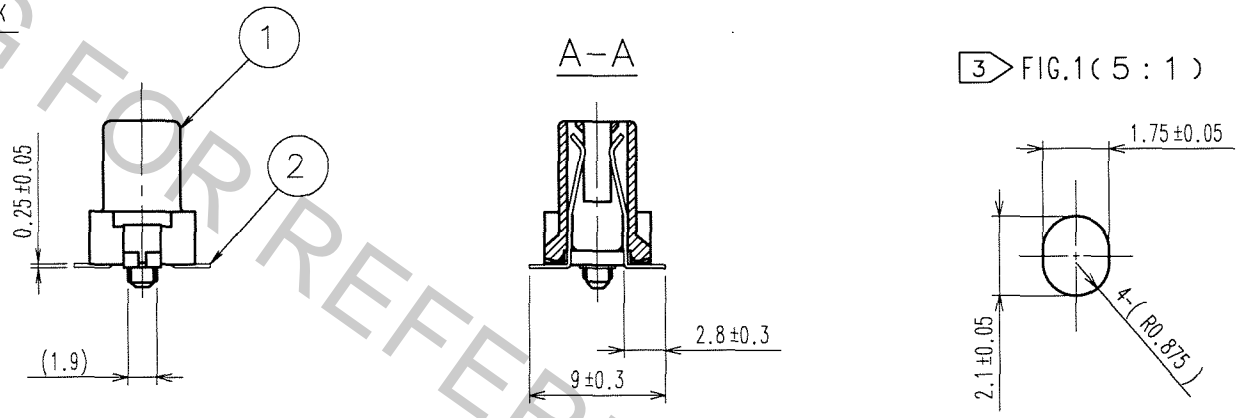
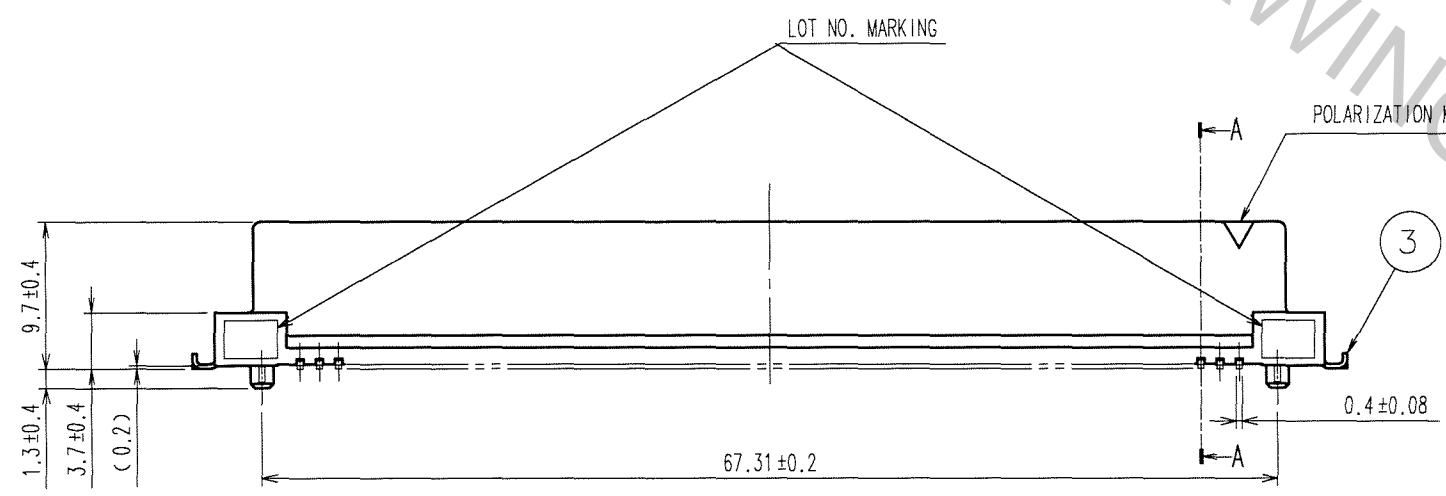
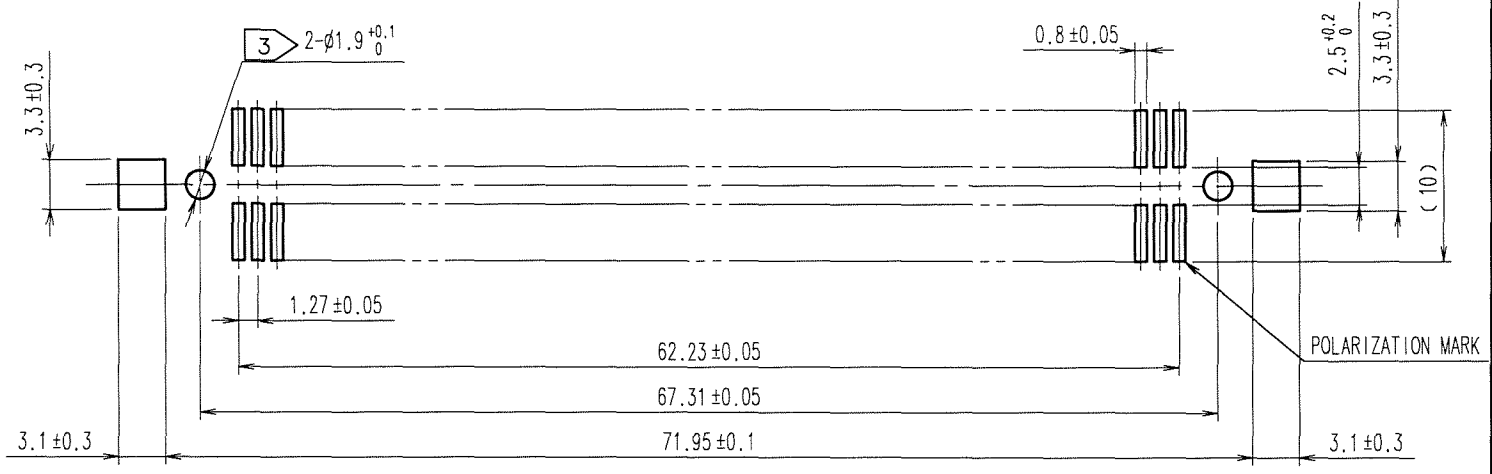
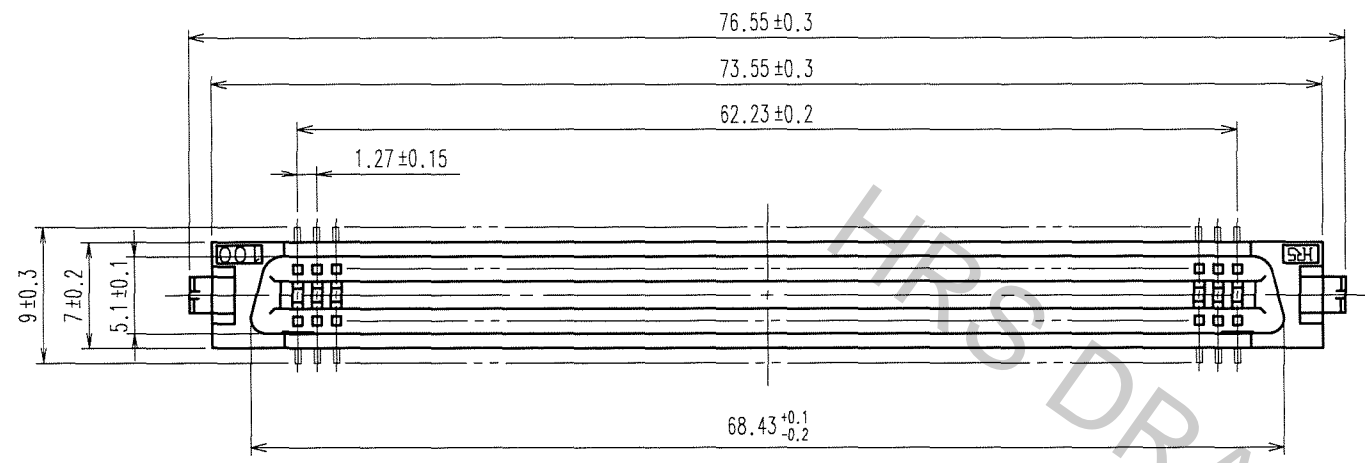

- NOTES
- 1 LEAD CO-PLANARITY SHALL BE 0.15 MAX.
 - 2 THE DIMENSIONS IN PARENTHESES ARE FOR REFERENCE.
 - 3 IN CASE OF THE AUTOMATED MOUNTING, RECOMMENDED HOLE DIAMETER OF BOSS IS SHOWN IN FIG.1.

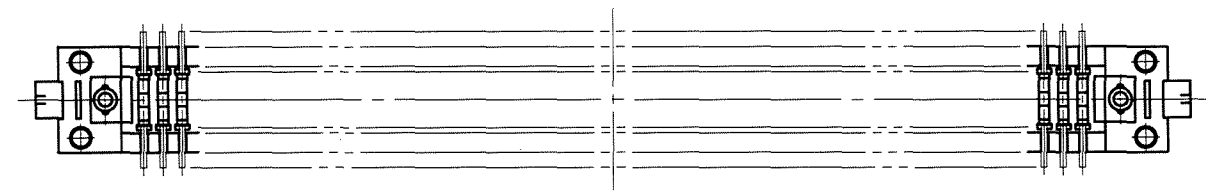

1	PPS	LIGHT BROWN (UL94V-0)	3	BRASS	TIN-PLATING
			2	PHOSPHOR BRONZE	CONTACT AREA:GOLD 0.2μ m min.
					LEAD AREA:TIN-PLATING 2μ m min.
					UNDER PLATING:NICKEL 1.5μ m min.
NO.	MATERIAL	FINISH, REMARKS	NO.	MATERIAL	FINISH, REMARKS

CODE NO. (OLD) CL	DRAWN S.KAMIGA '06.10.02	DESIGNED H. Nakamura '06.10.02	CHECKED H. Ogawa '06.10.02	APPROVED H. Okawa '06.10.02	RELEASED ..
----------------------	--------------------------------	--------------------------------------	----------------------------------	-----------------------------------	----------------

SCALE 2 : 1	DRAWING NO. EDC3-082425-21	PART NO. FX2-100S-1.27SVL(71)
UNITS mm	HRS HIROSE ELECTRIC CO., LTD	CODE NO. CL572-2158-0-71

TO
PCK

1/1