

**DESCRIPTION: HIGH DENSITY FEMALE - CRIMP AND LOAD**

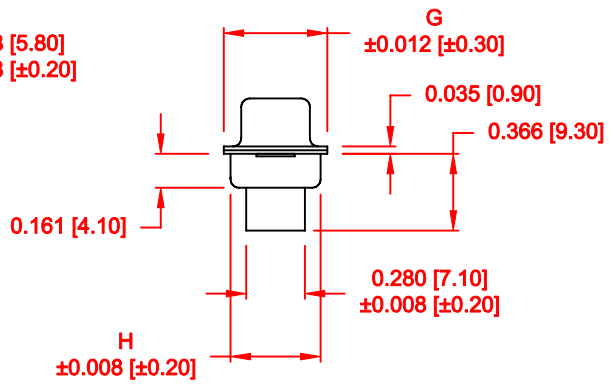
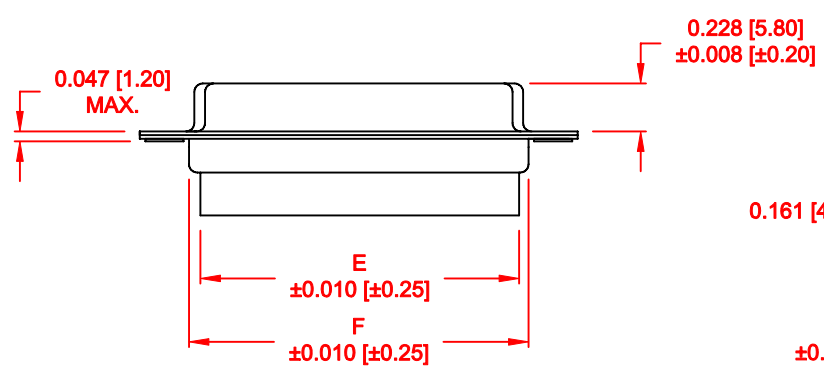

No. OF PINS	DIMENSIONS							
	B	C	D	E	F	G	H	
15	1.213	0.984	0.643	0.311	0.606	0.756	0.426	0.429
	30.80	24.99	16.34	7.90	15.40	19.20	12.60	10.90
26	1.541	1.312	0.966	0.311	0.954	1.091	0.426	0.429
	39.15	33.32	24.53	7.90	24.22	27.70	12.60	10.90
44	2.087	1.852	1.512	0.311	1.499	1.618	0.426	0.429
	53.00	47.04	38.40	7.90	38.08	41.10	12.60	10.90
62	2.728	2.500	2.156	0.311	2.147	2.256	0.426	0.429
	69.30	63.50	54.76	7.90	54.54	57.30	12.60	10.90
78	2.638	2.406	2.057	0.429	2.043	2.169	0.606	0.526
	67.00	61.10	52.26	10.90	51.90	55.10	15.40	13.35

4 ROWS

**180-YYY-27YLYY0**

- SERIES \_\_\_\_\_
- POSITIONS \_\_\_\_\_
- 015 \_\_\_\_\_
- 026 \_\_\_\_\_
- 044 \_\_\_\_\_
- 062 \_\_\_\_\_
- 078 \_\_\_\_\_
- GENDER \_\_\_\_\_
- 2 = FEMALE
- TERMINATION \_\_\_\_\_
- 7 = CRIMP & LOAD
- SHELL PLATING \_\_\_\_\_
- 2 = TIN
- 3 = NICKEL
- RoHS COMPLIANT (230°C) \_\_\_\_\_
- HARDWARE OPTIONS \_\_\_\_\_
- 00 = NO HARDWARE
- 01 = .098" CLINCH NUT (BOARD SIDE)
- 02 = .236" CLINCH NUT (BOARD SIDE)
- 03 = .236" CLINCH NUT (MATING SIDE)
- PLATING OPTIONS \_\_\_\_\_
- 0 = NO CONTACTS

**MATERIAL:**

- SHELL: STEEL, TIN OR NICKEL PLATED
- INSULATOR: PBT, UL 94V-O RATED, +30% FIBER-GLASS OR NYLON-66
- CONTACT: BRASS, GOLD PLATED OVER NICKEL

**ELECTRICAL:**

- CURRENT RATING: 5 AMPS
- CONTACT RESISTANCE: 15 mOhms Max.
- INSULATION RESISTANCE: 1,000 MOhms min.
- VOLTAGE: 500VAC FOR 1 MINUTE
- TEMPERATURE: -50° C TO 100° C

**RoHS COMPLIANT**

**DO NOT SCALE FROM DRAWING**

	THESE DRAWINGS AND SPECIFICATIONS ARE THE PROPERTY OF NorComp AND SHALL NOT BE REPRODUCED, COPIED OR USED AS THE BASIS FOR THE MANUFACTURE OF SALE OF APPARATUS WITHOUT WRITTEN PERMISSION.		DRAWN: <b>PAM JENKINS</b>	DATE: <b>7-19-05</b>
			CHECKED:	DATE:
<b>NorComp</b>		SCALE:	SHEET <b>1</b> OF <b>2</b>	REV <b>13</b>
		DWG NO. <b>180-YYY-27YLYY0</b>		

**TOLERANCE:**  
ALL DIMENSIONS ARE ±0.010

**ALL CLINCH-NUTS ARE 4-40 INTERNAL THREADS**

01X ..... 0.065" (BOARD SIDE) - CN1



02X ..... 0.236" (BOARD SIDE) - CN2

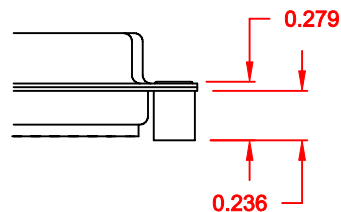

03X..... 0.236" (MATING SIDE) - CN8

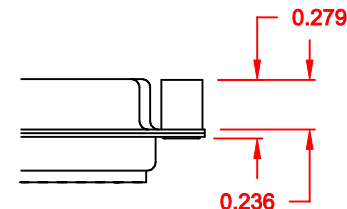

**DO NOT SCALE FROM DRAWING**

**RoHS COMPLIANT**

	THESE DRAWINGS AND SPECIFICATIONS ARE THE PROPERTY OF NorComp AND SHALL NOT BE REPRODUCED, COPIED OR USED AS THE BASIS FOR THE MANUFACTURE OF SALE OF APPARATUS WITHOUT WRITTEN PERMISSION.		DRAWN: <b>WAYNE ROBBINS</b>	DATE: <b>11-28-05</b>	
			CHECKED:	DATE:	
<h1>NorComp</h1>			SCALE:	SHEET <b>2</b> OF <b>2</b>	REV <b>13</b>
			DWG NO. <b>180-YYY-27YLYY0</b>		