

REVISIONS				
REV	ECN	DESCRIPTION	DATE	APPROVED
F		MATING END POSITION ADDED	APR 20/06	ZLJ
G		PIN LABELS ADDED	APR 06/10	SLJ
H		CORRECTION TO HOUSING CONFIGURATION DISPLAYED	APR 26/10	SLJ

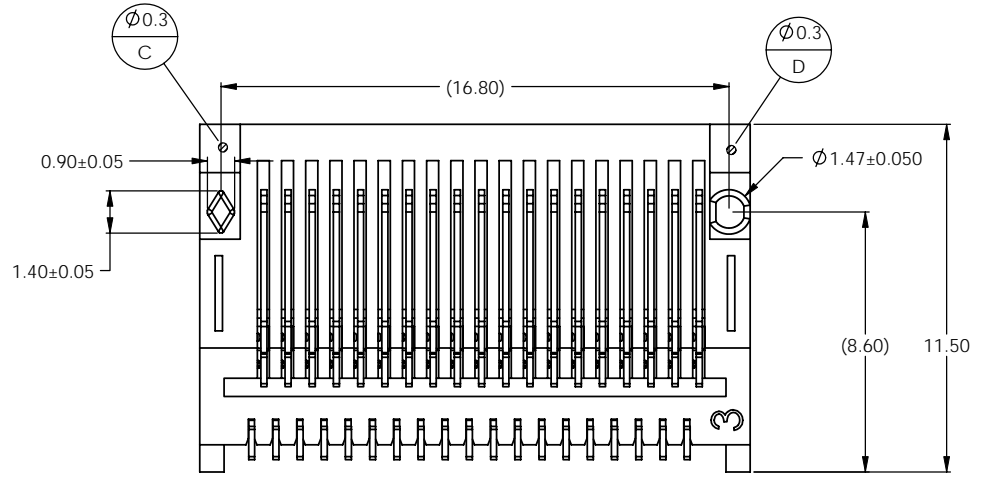

PART NUMBER	PACKAGING	CONTACT PLATING
FS1-R38-2000	TAPE AND REEL	30µ" GOLD OVER 50µ" NICKEL IN CONTACT AREAS 100µ" MATTE TIN OVER 50µ" NICKEL IN SOLDER AREAS
FS1-R38-3000		15µ" GOLD OVER 50µ" NICKEL IN CONTACT AREAS 100µ" MATTE TIN OVER 50µ" NICKEL IN SOLDER AREAS

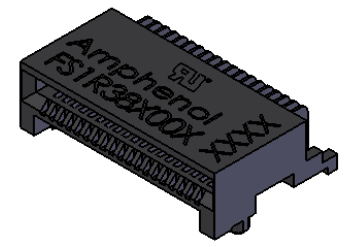
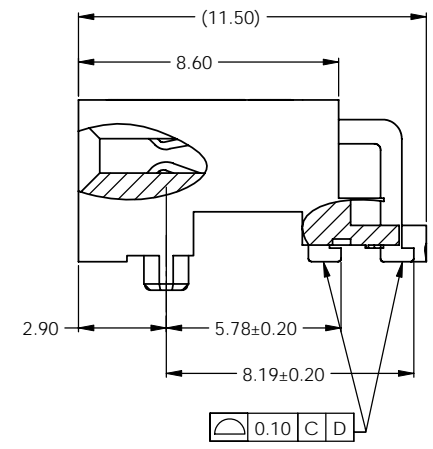
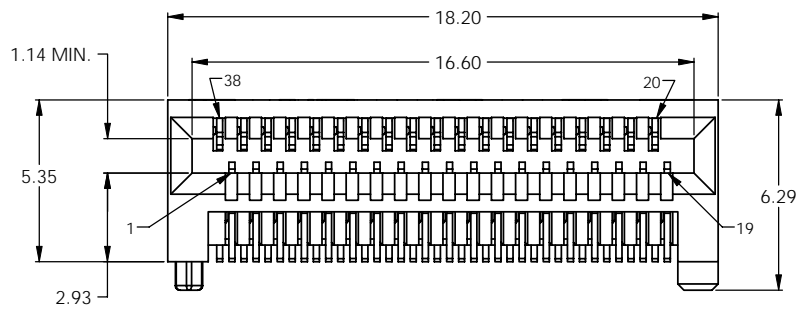
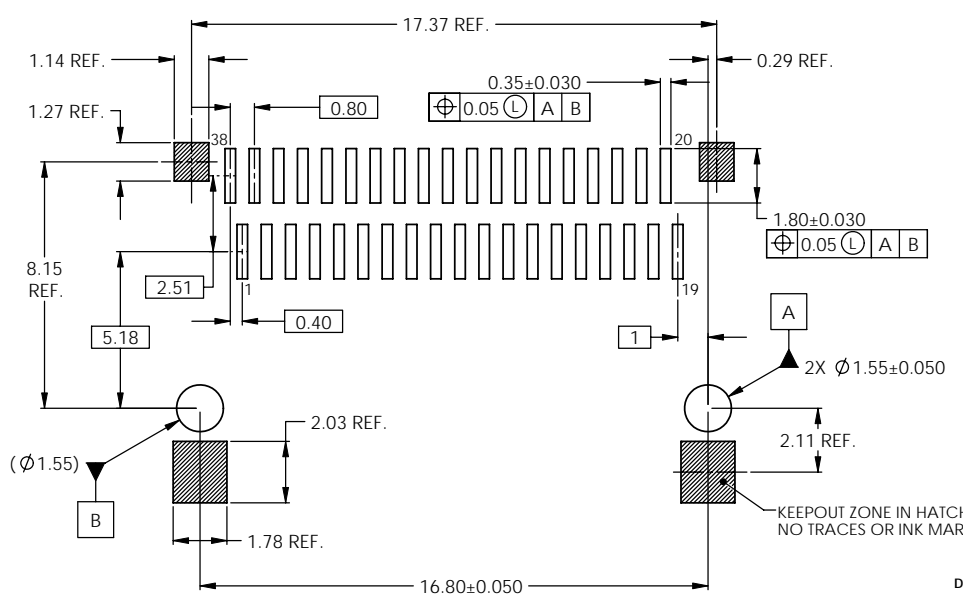

- NOTES:
- MATERIAL:
HOUSING: SOLDER REFLOW PROCESS COMPATIBLE LCP, UL94V-0
CONTACTS: PHOSPHOR BRONZE
 - ROHS COMPLIANT
 - PERFORMANCE:
ELECTRICAL: 0.5 AMPS MAX. PER CONTACT
MECHANICAL: 250 MATING CYCLES MINIMUM
 - COMPLIES WITH SFF 8436.

DO NOT SCALE DRAWING

RECOMMENDED PCB LAYOUT

THIS DOCUMENT CONTAINS PROPRIETARY INFORMATION AND SUCH INFORMATION MAY NOT BE DISCLOSED TO OTHERS FOR ANY PURPOSE OR USED FOR MANUFACTURING PURPOSES WITHOUT PERMISSION FROM AMPHENOL CANADA CORP.

UNLESS OTHERWISE SPECIFIED DIMENSIONS ARE IN MILLIMETERS		APPROVALS	DATE	Amphenol Canada Corp.	
DECIMALS	ANGLES	DRAWN	21/APR/06	TITLE	
.X ± 0.25	± 2°	DESIGNED	21/APR/06	38 POSITION RIGHT ANGLE HIGH SPEED CONNECTOR	
.XX ± 0.13		CHECKED		SCALE	
MATERIAL AND FINISH		DR. APP'D		PROJECT	
ENG. REL. NO.		ENG. APP'D		DRAWG. NO.	
EAR 12923				P-FS1-R38-X000	REV. H
CODE IDENT. NO.	03554	DRG. APP'D		SCALE	
				NTS	SHEET 1 OF 1