

REVISIONS				
REV.	ECO. NO	DESCRIPTION	DATE	BY
B	2617	ADD 03-POSITION & RJ TERMINATION OPTIONS, UPDATE DIM 'F' TOLERANCE & DWG FORMAT	6/13/2012	JH
C	2511	ADDED S38, S81 & S328 OPTIONS	2/6/2013	KV
D	3088	ADD 'C' AND 'F' MATERIAL CODES TO S328 MODIFICATION	10/24/2014	JHSU
E	3232	ADD 14 POSITION TO DIM TABLE, ADD 'X' MATERIAL, S1098, S1860 OPTIONS, UPDATE BOM ON PRODUCTION DWG	5/21/2015	MG

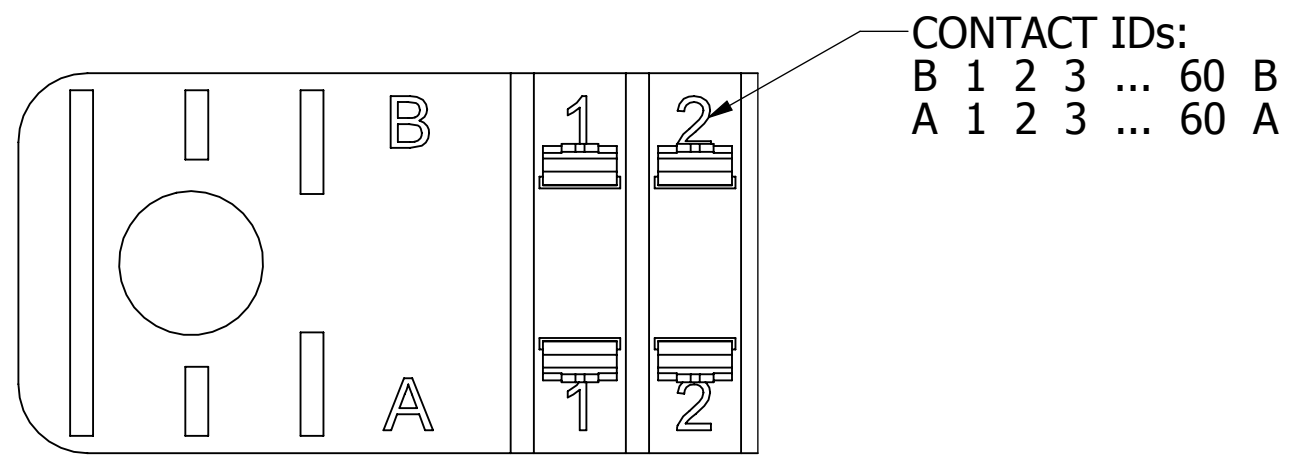

- NOTES:**
- INSULATOR MATERIAL: SEE PART NUMBER CODING
 - CONTACT MATERIAL: SEE PART NUMBER CODING
 - PLATING: SEE PART NUMBER CODING
 - OPERATING TEMPERATURE: SEE PART NUMBER CODING
 - PROCESSING TEMP: SEE PART NUMBER CODING
 - UL FLAMMABILITY RATING: 94V-0
 - OPERATING VOLTAGE: 700 VAC
 - CURRENT RATING: 3 AMP
 - CONTACT RESISTANCE: 30 MILLI OHMS MAX
 - INSULATION RESISTANCE: 5000 MEGA OHMS
 - DURABILITY: 500 CYCLES MIN
 - CONNECTOR IDENTIFICATION: THE PART SHALL BE MARKED WITH A PART NUMBER AND LOT CODE
 - BOARD THICKNESS ACCOMMODATED: $.062 \pm .008 [1.57 \pm 0.20]$
 - INSERTION FORCE: 16 OZ MAX PER CONTACT PAIR WHEN USING A $.062 [1.57]$ TEST BLADE
INTERNAL INSPECTION TO BE PER SULLINS WORK INSTRUCTION WI7.3-01
 - WITHDRAWAL FORCE: 1 OZ MIN PER CONTACT PAIR USING $.062 [1.57]$ PCB
 - MODIFICATION: SEE PART NUMBER CODING

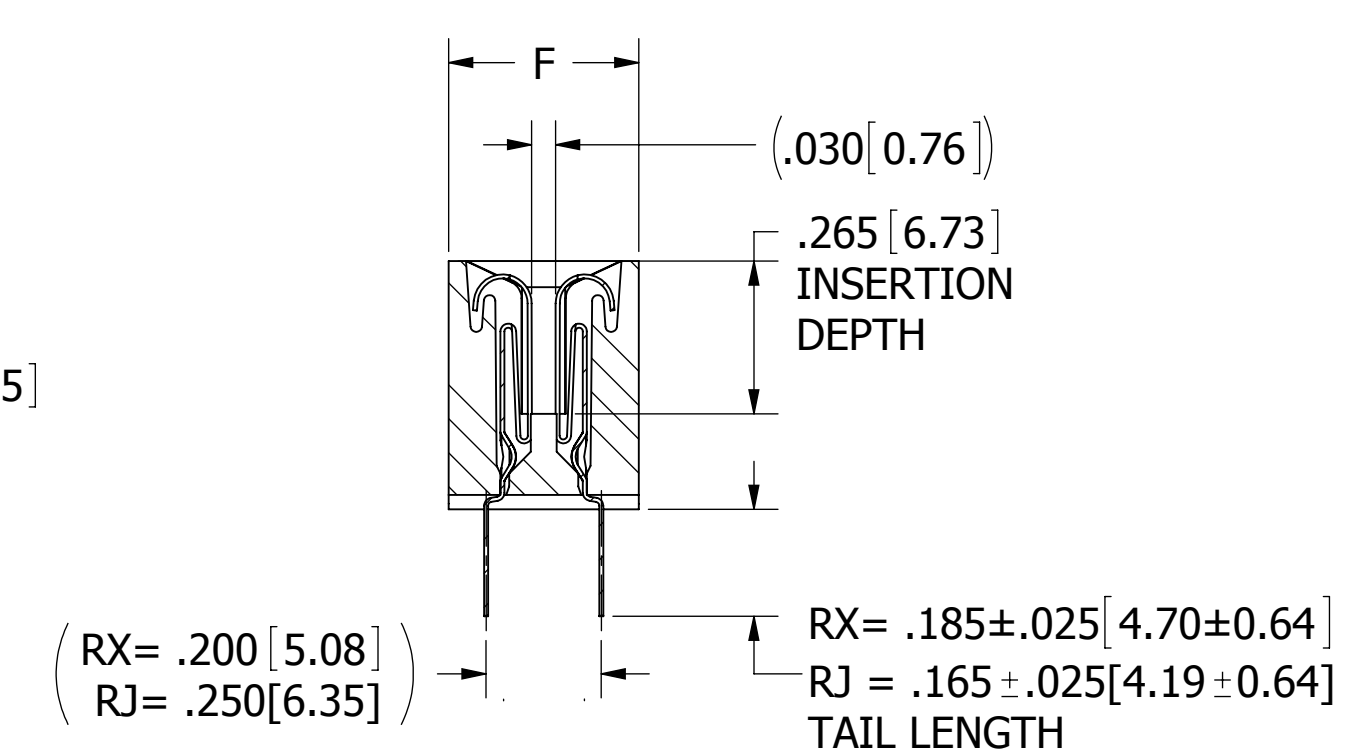
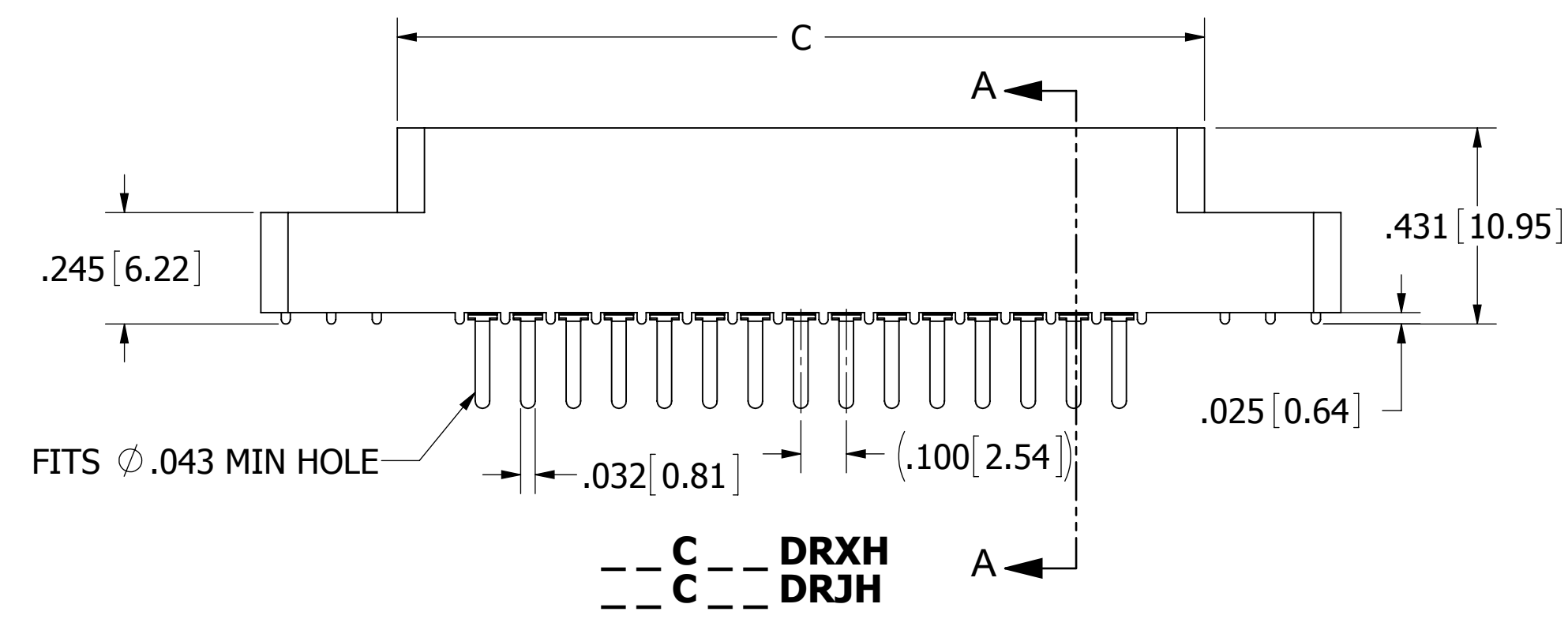
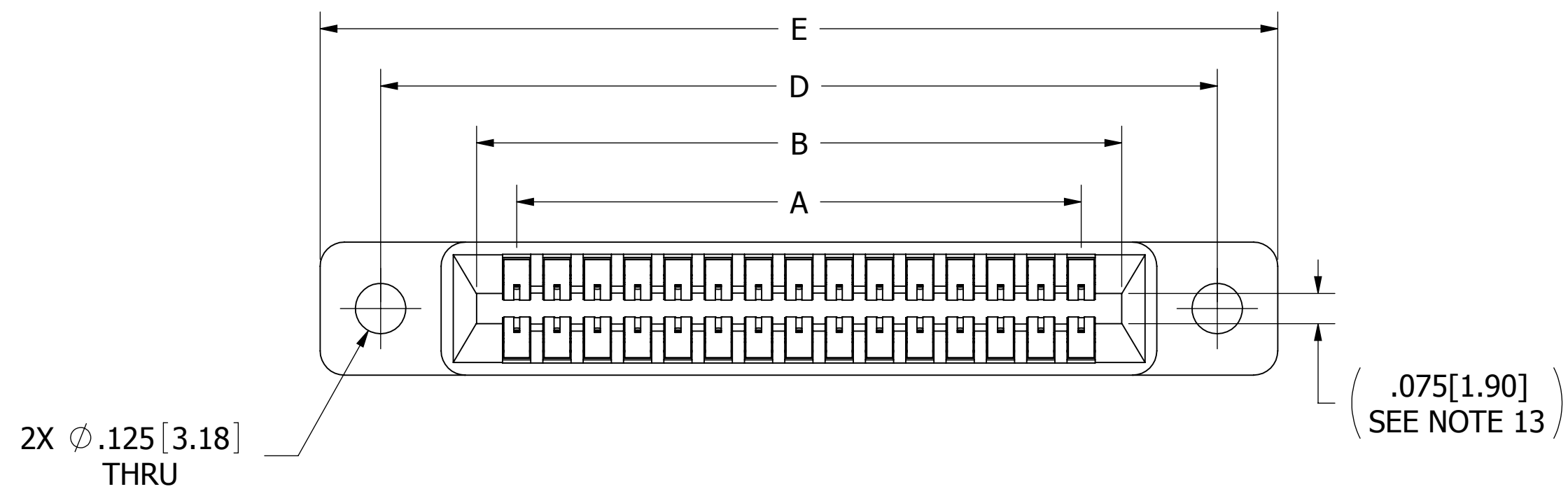

UNLESS OTHERWISE SPECIFIED: DIMENSIONS ARE IN INCHES [MM]

TOLERANCES:
ANGULAR: $\pm 1^\circ$
DECIMALS
.XX = $\pm .02 [.5]$
.XXX = $\pm .005 [.13]$
.XXXX = $\pm .0005 [.013]$

DRAWN	DATE	NAME		
	6/14/2012	JH		
<small>THE INFORMATION HEREIN CONTAINS PROPRIETARY INFORMATION OF SULLINS ELECTRONICS AND IS NOT TO BE REPRODUCED, USED OR DISCLOSED TO OTHERS FOR ANY PURPOSE EXCEPT AS SPECIFICALLY AUTHORIZED IN WRITING BY AN OFFICER OF SULLINS ELECTRONICS.</small>			TITLE CONNECTOR, .100 CC LP	
PART NUMBER C --- DRX (RJ) _(-S38, S81, S328, S1098, S1860)			SIZE C	CAGE CODE 54453
SCALE: 2:1			DWG. NO. C10881	REV E
			SHEET 1 OF 3	

CUSTOMER COPY

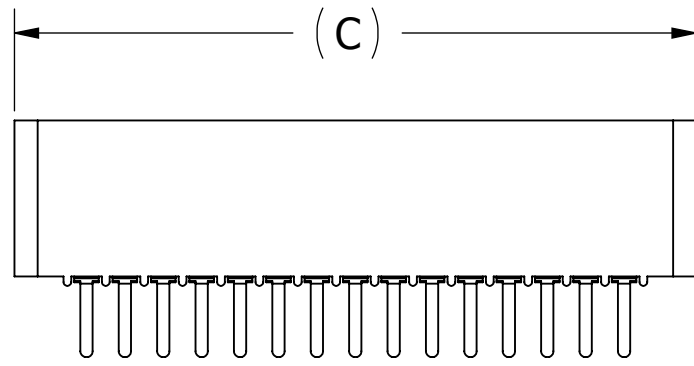
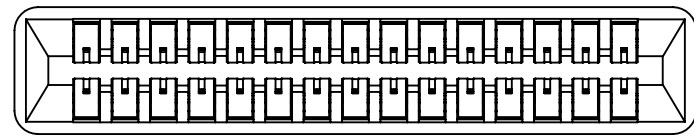

--- C --- DRXN
--- C --- DRJN

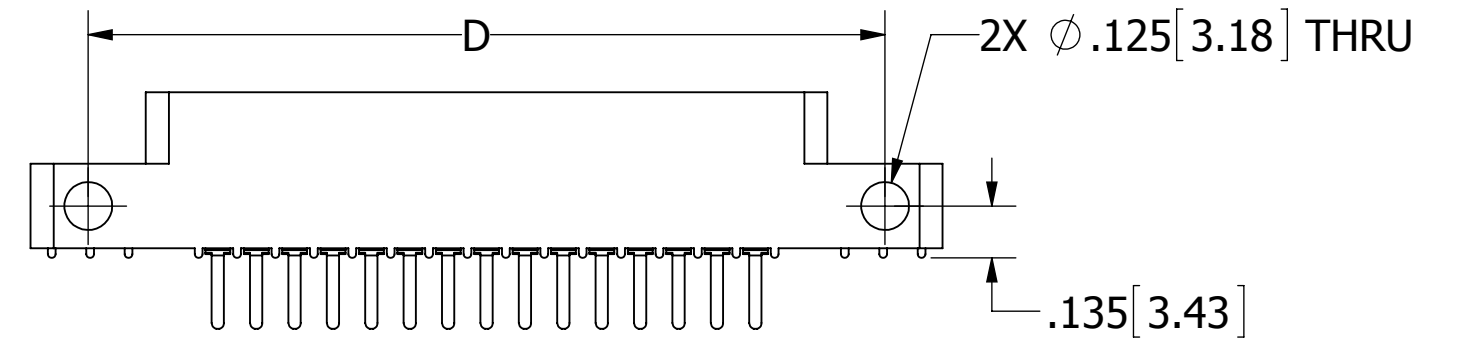
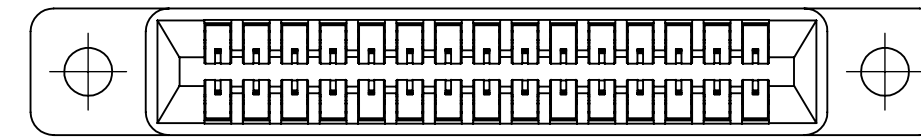

--- C --- DRXS
--- C --- DRJS

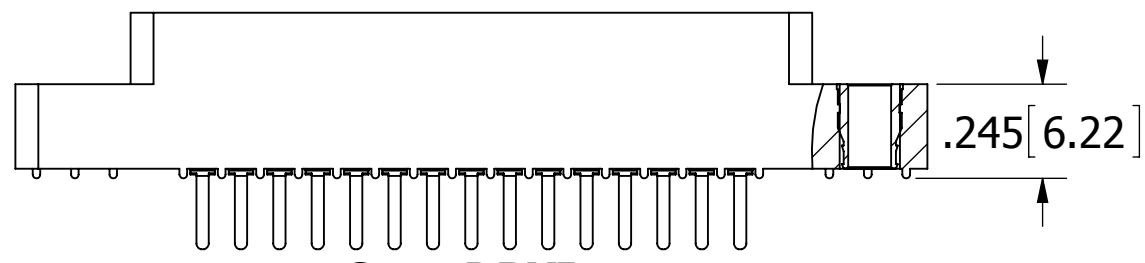
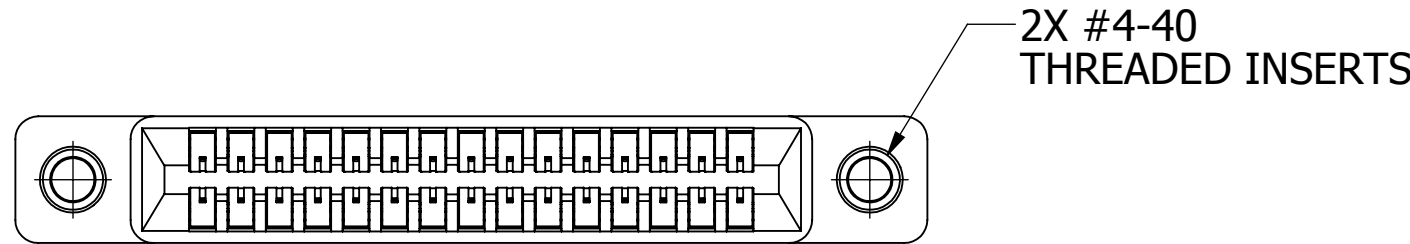

--- C --- DRXI
--- C --- DRJI

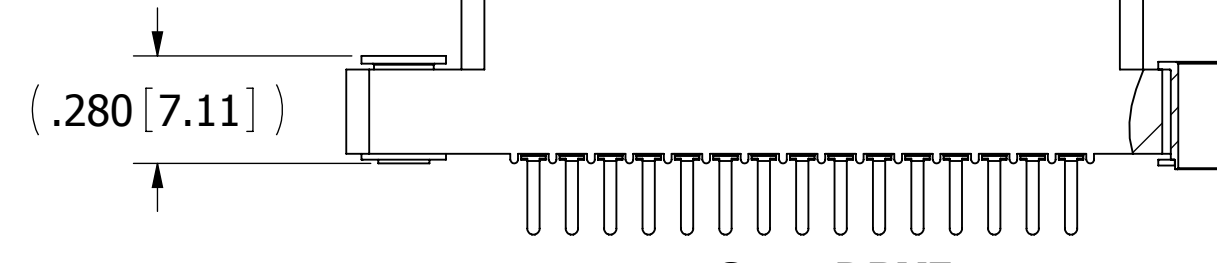
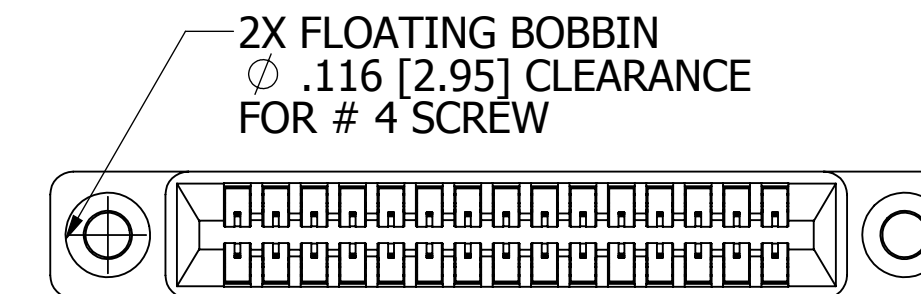

--- C --- DRXF
--- C --- DRJF

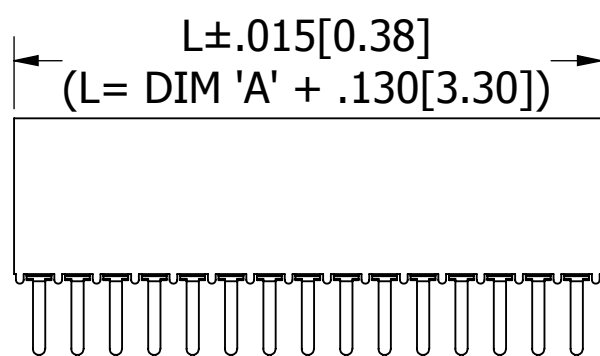
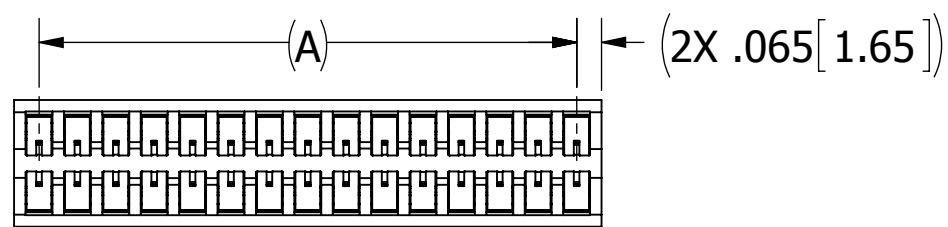

--- C --- DRXB
--- C --- DRJB

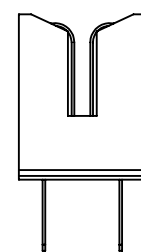

CUSTOMER COPY



UNLESS OTHERWISE SPECIFIED: DIMENSIONS ARE IN INCHES [MM]	DRAWN	DATE	NAME	
		6/14/2012	JH	
TOLERANCES: ANGULAR: ± 1° DECIMALS .XX = ± .02 [.5] .XXX = ± .005 [.13] .XXXX = ± .0005 [.013]	<small>THE INFORMATION HEREIN CONTAINS PROPRIETARY INFORMATION OF SULLINS ELECTRONICS AND IS NOT TO BE REPRODUCED, USED OR DISCLOSED TO OTHERS FOR ANY PURPOSE EXCEPT AS SPECIFICALLY AUTHORIZED IN WRITING BY AN OFFICER OF SULLINS ELECTRONICS.</small>			TITLE CONNECTOR, .100 CC LP
	PART NUMBER --- C --- DRX (RJ) _(-S38, S81, S328, S1098, S1860)			
	SIZE	CAGE CODE	DWG. NO.	
	C	54453	C10881	
SCALE: 2:1			SHEET 2 OF 3	

PART NUMBER	NO. OF POS.	A±.008[0.20]		B±.008[0.20]		C±.015[0.38]		D±.010[0.25]		E±.020[0.51]		F+.005/- .015[+0.13/-0.38]	
		IN	MM	IN	MM	IN	MM	IN	MM	IN	MM	IN	MM
__C03DRX (RJ) B	3	0.200	5.08	'B' MOUNTING ONLY									
__C04DRX (RJ) __	4	0.300	7.62	0.500	12.70	0.675	17.15	0.975	24.77	1.275	32.39	0.330	8.38
__C05DRX (RJ) __	5	0.400	10.16	0.600	15.24	0.775	19.69	1.075	27.31	1.375	34.93		
__C06DRX (RJ) __	6	0.500	12.70	0.700	17.78	0.875	22.23	1.175	29.85	1.475	37.47		
__C07DRX (RJ) __	7	0.600	15.24	0.800	20.32	0.975	24.77	1.275	32.39	1.575	40.01		
__C08DRX (RJ) __	8	0.700	17.78	0.900	22.86	1.075	27.31	1.375	34.93	1.675	42.55		
__C10DRX (RJ) __	10	0.900	22.86	1.100	27.94	1.275	32.39	1.575	40.01	1.875	47.63		
__C12DRX (RJ) __	12	1.100	27.94	1.300	33.02	1.475	37.47	1.775	45.09	2.075	52.71		
__C13DRX (RJ) __	13	1.200	30.48	1.400	35.56	1.575	40.01	1.875	47.63	2.175	55.25		
__C14DRX (RJ) __	14	1.300	33.02	1.500	38.10	1.675	42.55	1.975	50.17	2.275	57.79		
__C15DRX (RJ) __	15	1.400	35.56	1.600	40.64	1.775	45.09	2.075	52.71	2.375	60.33		
__C17DRX (RJ) __	17	1.600	40.64	1.800	45.72	1.975	50.17	2.275	57.79	2.575	65.41		
__C18DRX (RJ) __	18	1.700	43.18	1.900	48.26	2.075	52.71	2.375	60.33	2.675	67.95		
__C19DRX (RJ) __	19	1.800	45.72	2.000	50.80	2.175	55.25	2.475	62.87	2.775	70.49		
__C20DRX (RJ) __	20	1.900	48.26	2.100	53.34	2.275	57.79	2.575	65.41	2.875	73.03		
__C22DRX (RJ) __	22	2.100	53.34	2.300	58.42	2.475	62.87	2.775	70.49	3.075	78.11		
__C23DRX (RJ) __	23	2.200	55.88	2.400	60.96	2.575	65.41	2.875	73.03	3.175	80.65		
__C25DRX (RJ) __	25	2.400	60.96	2.600	66.04	2.775	70.49	3.075	78.11	3.375	85.73		
__C26DRX (RJ) __	26	2.500	63.50	2.700	68.58	2.875	73.03	3.175	80.65	3.475	88.27		
__C28DRX (RJ) __	28	2.700	68.58	2.900	73.66	3.075	78.11	3.375	85.73	3.675	93.35		
__C30DRX (RJ) __	30	2.900	73.66	3.100	78.74	3.275	83.19	3.575	90.81	3.875	98.43		
__C31DRX (RJ) __	31	3.000	76.20	3.200	81.28	3.375	85.73	3.675	93.35	3.975	100.97		
__C35DRX (RJ) __	35	3.400	86.36	3.600	91.44	3.775	95.89	4.075	103.51	4.375	111.13	0.400	10.16
__C36DRX (RJ) __	36	3.500	88.90	3.700	93.98	3.875	98.43	4.175	106.05	4.475	113.67		
__C40DRX (RJ) __	40	3.900	99.06	4.100	104.14	4.275	108.59	4.575	116.21	4.875	123.83		
__C43DRX (RJ) __	43	4.200	106.68	4.400	111.76	4.575	116.21	4.875	123.83	5.175	131.45		
__C44DRX (RJ) __	44	4.300	109.22	4.500	114.30	4.675	118.75	4.975	126.37	5.275	133.99		
__C49DRX (RJ) __	49	4.800	121.92	5.000	127.00	5.175	131.45	5.475	139.07	5.775	146.69		
__C50DRX (RJ) __	50	4.900	124.46	5.100	129.54	5.275	133.99	5.575	141.61	5.875	149.23		
__C52DRX (RJ) __	52	5.100	129.54	5.300	134.62	5.475	139.07	5.775	146.69	6.075	154.31		
__C60DRX (RJ) __	60	5.900	149.86	6.100	154.94	6.275	159.39	6.575	167.01	6.875	174.63		
__C65DRX (RJ) __	65	6.400	162.56	6.600	167.64	6.775	172.09	7.075	179.71	7.375	187.33		

PART NUMBER CODING

MATERIAL (INSULATOR/CONTACT)

E = BLUE PBT/PHOSPHOR BRONZE
 OPERATING TEMP: -65°C TO +125°C
 PROCESSING TEMP: WAVE/ MANUAL SOLDERING ONLY

R = GREEN PPS/PHOSPHOR BRONZE
 OPERATING TEMP: -65°C TO +125°C
 PROCESSING TEMP: 260°C MAX FOR 20 SECONDS

G = BLACK PA9T/PHOSPHOR BRONZE
 OPERATING TEMP: -65°C TO +125°C
 PROCESSING TEMP: 260°C MAX FOR 20 SECONDS

H = BLUE PBT/BERYLLIUM COPPER
 OPERATING TEMP: -65°C TO +125°C
 PROCESSING TEMP: WAVE/ MANUAL SOLDERING ONLY

A = GREEN PPS/BERYLLIUM COPPER
 OPERATING TEMP: -65°C TO +150°C
 PROCESSING TEMP: 260°C MAX FOR 20 SECONDS

J = BLACK PA9T/BERYLLIUM COPPER
 OPERATING TEMP: -65°C TO +150°C
 PROCESSING TEMP: 260°C MAX FOR 20 SECONDS

F = GREEN PPS/SPINODAL (CONSULT FACTORY)
 OPERATING TEMP: -65°C TO +200°C
 PROCESSING TEMP: 260°C MAX FOR 20 SECONDS
 AVAILABLE IN OVERALL GOLD ONLY (S OR M PLATING CODE)
 (CONSULT FACTORY FOR SPECIAL SOLDERING GUIDELINES)

C = GREEN PPS/BERYLLIUM NICKEL (CONSULT FACTORY)
 OPERATING TEMP: -65°C TO +200°C
 PROCESSING TEMP: 260°C MAX FOR 20 SECONDS
 AVAILABLE IN OVERALL GOLD ONLY (S OR M PLATING CODE)

X = NATURAL BROWN PEEK/SPINODAL (CONSULT FACTORY)
 OPERATING TEMP: -65°C TO +200°C
 PROCESSING TEMP: 260°C MAX FOR 20 SECONDS
 AVAILABLE IN OVERALL GOLD ONLY (S OR M PLATING CODE)
 (CONSULT FACTORY FOR SPECIAL SOLDERING GUIDELINES)

W = NATURAL BROWN PEEK/BERYLLIUM NICKEL (CONSULT FACTORY)
 OPERATING TEMP: -65°C TO +250°C
 PROCESSING TEMP: 260°C MAX FOR 20 SECONDS
 AVAILABLE IN OVERALL M PLATING ONLY

MODIFICATION CODE
 OMIT FOR STANDARD, EX: 'EBC22DRXH'
 S38 = BLACK PBT (MATERIAL CODES 'E' OR 'H' ONLY)
 S81 = GREEN PBT (MATERIAL CODES 'E' OR 'H' ONLY)
 S328 = BROWN PPS (MATERIAL CODES 'R', 'A', 'F', OR 'C' ONLY)
 S1098 = BLACK PPS (MATERIAL CODES 'R', 'A', 'F', OR 'C' ONLY)
 S1860 = GREEN PPS (MATERIAL CODES 'R', 'A', 'F', OR 'C' ONLY)

MOUNTING STYLE
 H = .125" DIA. CLEARANCE HOLES
 N = NO MOUNTING EARS
 S = .125" DIA. SIDE MOUNTING
 I = #4-40 THREADED INSERT
 F = FLOATING BOBBIN
 B = OPEN CARDSLOT

TERMINATION
 RX = .200" [5.08] ROW SPACING X .185" [4.70] DIP SOLDER TAIL LENGTH
 RJ = .250" [6.35] ROW SPACING X .165" [4.19] DIP SOLDER TAIL LENGTH
 (SEE SECTION A-A ON PAGE 1)

NUMBER OF POSITIONS
 (CONTACTS PER ROW)

PLATING
 ALL PLATINGS HAVE .000050" NICKEL UNDERPLATE

CONTACT SURFACE	TERMINATION
B = .000010" GOLD	.000100" PURE TIN, MATTE
C = .000030" GOLD	.000100" PURE TIN, MATTE
G = .000010" GOLD	.000005" GOLD
Y = .000030" GOLD	.000005" GOLD
M = .000030" GOLD	.000010" GOLD OVERALL
S = .000010" GOLD OVERALL	
*E = .000100" PURE TIN, MATTE OVERALL	

*OVERALL TIN ONLY AVAILABLE ON MATERIAL CODES E, R, & G

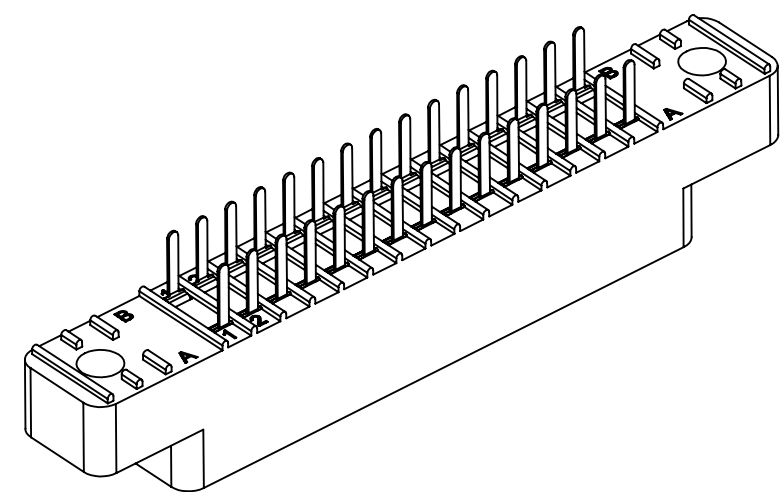

CUSTOMER COPY

UNLESS OTHERWISE SPECIFIED: DIMENSIONS ARE IN INCHES [MM]		DRAWN	DATE	NAME	
TOLERANCES: ANGULAR: ± 1° DECIMALS .XX = ± .02 [.5] .XXX = ± .005 [.13] .XXXX = ± .0005 [.013]			6/14/2012	JH	
THE INFORMATION HEREIN CONTAINS PROPRIETARY INFORMATION OF SULLINS ELECTRONICS AND IS NOT TO BE REPRODUCED, USED OR DISCLOSED TO OTHERS FOR ANY PURPOSE EXCEPT AS SPECIFICALLY AUTHORIZED IN WRITING BY AN OFFICER OF SULLINS ELECTRONICS.					PART NUMBER __C__DRX (RJ) _(-S38, S81, S328, S1098, S1860)
SIZE	CAGE CODE	DWG. NO.	REV		
C	54453	C10881	E		
SCALE: 2:1		SHEET 3 OF 3			

