

Aug.1.2018 Copyright 2018 HIROSE ELECTRIC CO., LTD. All Rights Reserved.
 In case that the application demands a high level of reliability, such as automotive,
 please contact a company representative for further information.

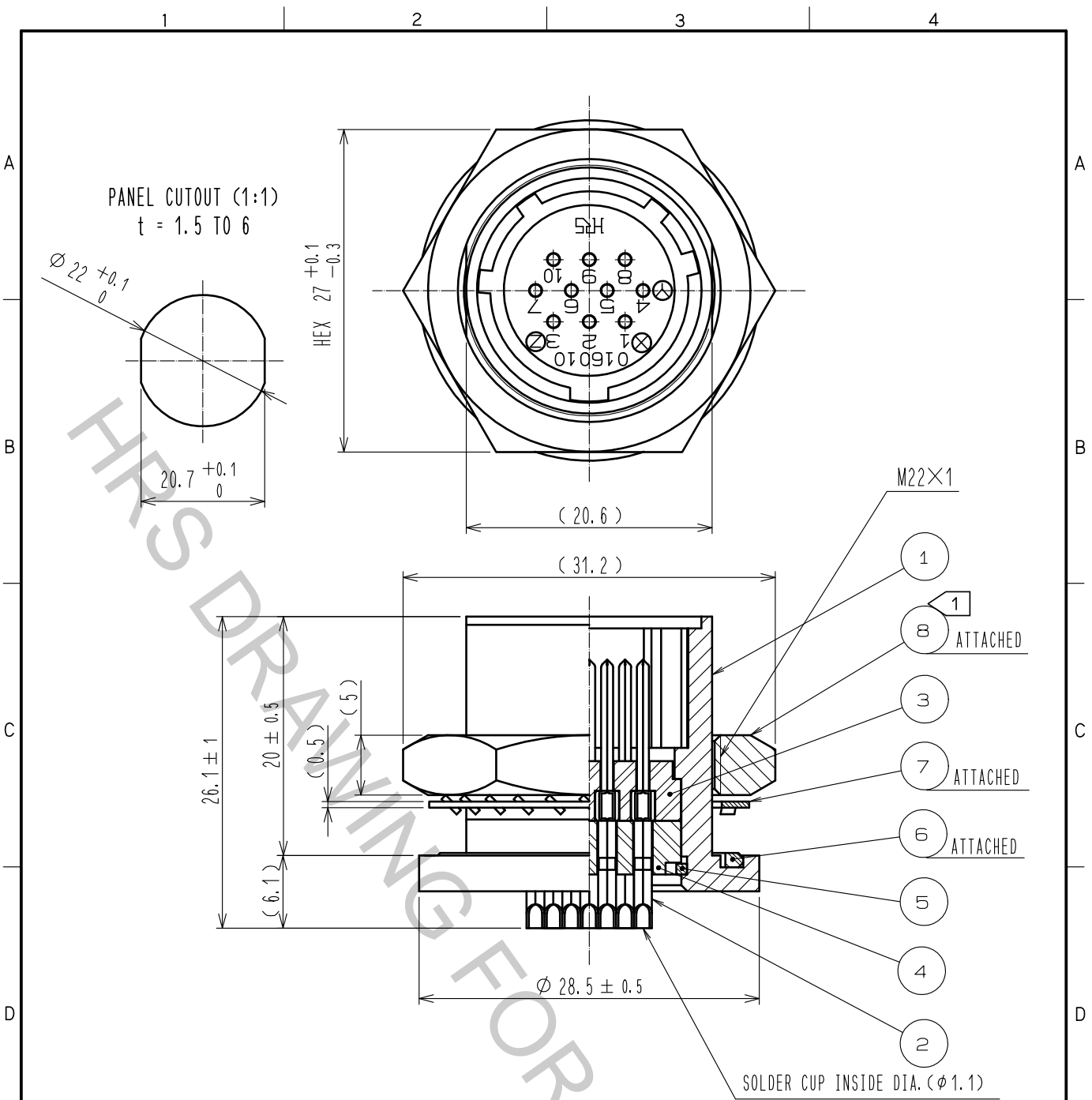

NOTE ① THE RECOMMENDED TIGHTENING TORQUE OF REF. NO. ⑧ : 3 TO 3.5 N · m.
 THREAD LOCKER TO THE THREADED PORTION OF REF. NO. ① IS RECOMMENDED TO
 PREVENT REF. NO. ⑧ FROM LOSING.
 RECOMMENDED THREAD LOCKER: LOCTITE 263, HENKEL JAPAN CO. LTD.

4	PHENOL-FORMALDEHYDE	(BLACK) UL94V-0	8	BRASS	BLACK CHROME PLATING
3	PHENOL-FORMALDEHYDE	(BLACK) UL94V-0	7	PHOSPHOR BRONZE	BLACK CHROME PLATING
2	COPPER ALLOY	SILVER PLATING 3 μ m min.	6	ACRYLONITRILE BUTADIENE RUBBER	(BLACK)
1	ALUMINUM ALLOY	BLACK CHROME PLATING	5	PHOSPHOR BRONZE	NICKEL PLATING
NO.	MATERIAL	FINISH . REMARKS	NO.	MATERIAL	FINISH . REMARKS

UNITS mm		SCALE 2 : 1	COUNT 	DESCRIPTION OF REVISIONS	DESIGNED	CHECKED	DATE
HRS HIROSE ELECTRIC CO., LTD.		APPROVED :HY. KOBAYASHI	18.02.26	DRAWING NO.	EDC-110499-31-00		
		CHECKED :HY. KOBAYASHI	18.02.26	PART NO.	JR16WRA-10P(31)		
		DESIGNED :TH. KAMEYA	18.02.24	CODE NO.	CL114-2096-1-31		
		DRAWN :MK. INOUE	18.02.14				1/1