

© 1967 BY AMP INCORPORATED. ALL RIGHTS RESERVED. AMP PRODUCTS COVERED BY PATENTS AND/OR PATENTS PENDING. APPROVED PER GOVT CONTRACT NO.

LOCATION FOR AMP-TAB FEMALE CONTACT

CAVITY IDENTIFICATION ON P/N (I)-582587-T ONLY.

(I)-582587-1. SAME AS -1 EXCEPT TO HAVE CAVITY IDENT. ON TOP SURFACE OF HOUSING.

ZONE		LTR		DESCRIPTION	DATE	APPROVED
				ECO-08-020973	PY 11-08	JW

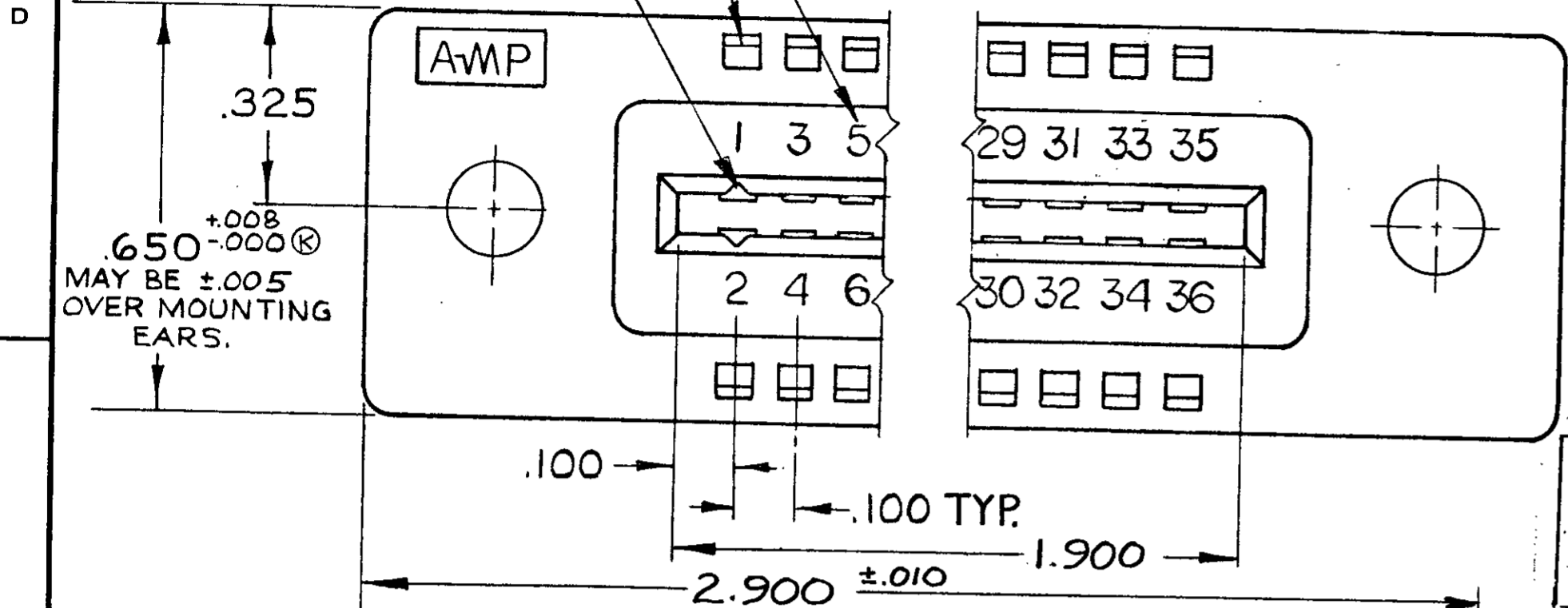

582587-1 1. AS SHOWN "J" DIA. HOLES = .128
 OBS 582587-2 1. SAME AS -1 EXCEPT: "J" DIA. HOLES = .156

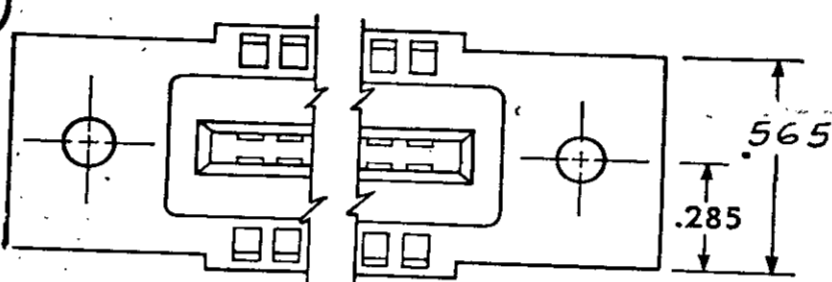

ALTERNATE MOUNTING EAR CONFIGURATION

4. SAME AS -1 EXCEPT: OBSOLETE FLOATING BUSHINGS. (SEE DETAIL "B")
 5. SAME AS -1 EXCEPT: FLOATING BUSHINGS. (SEE DETAIL "C")

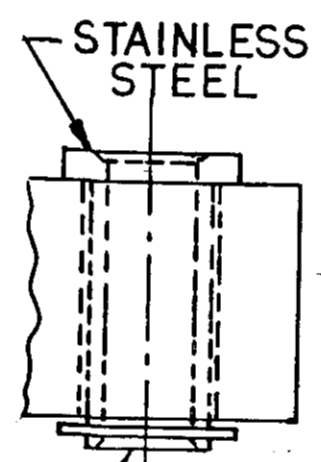
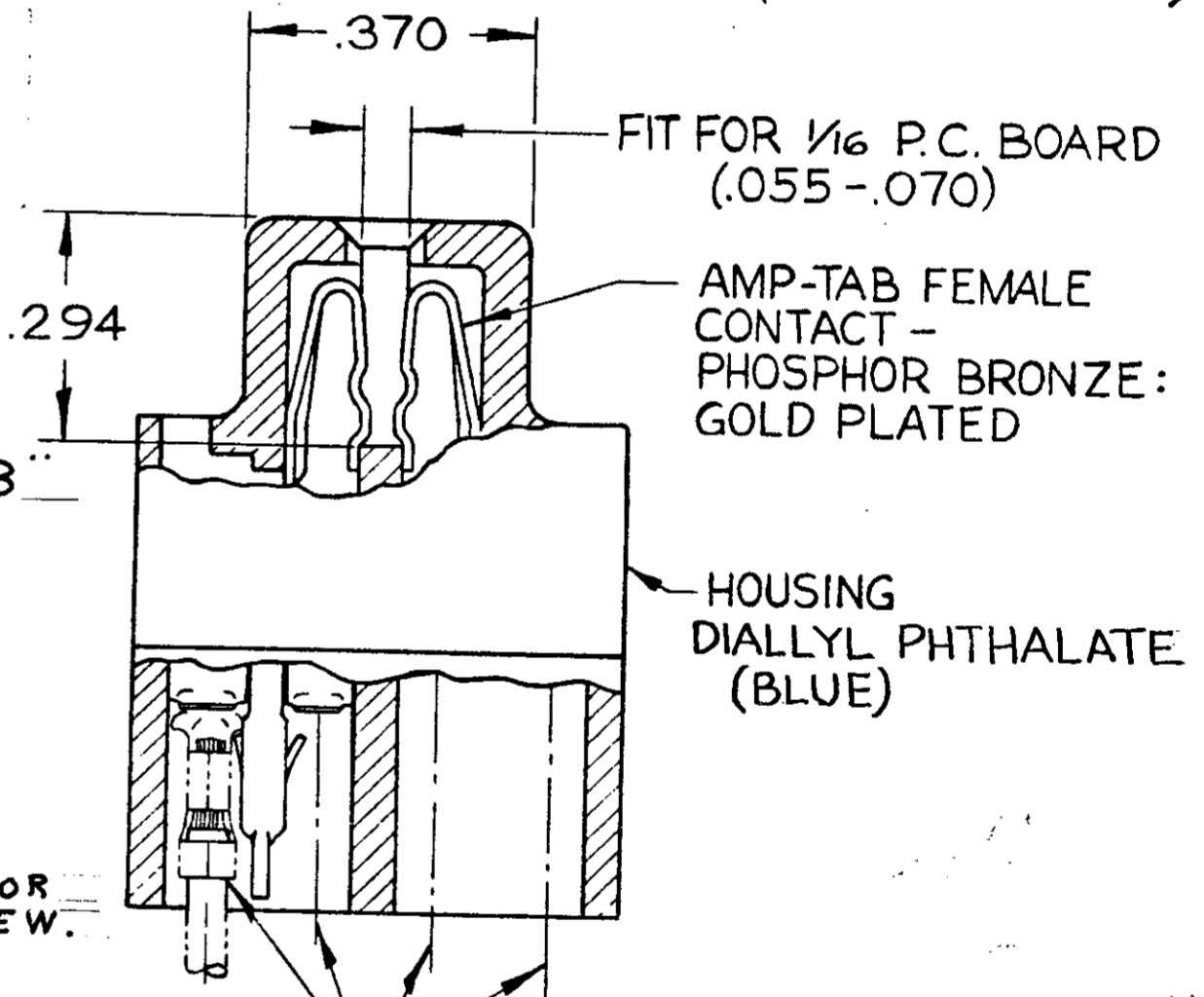
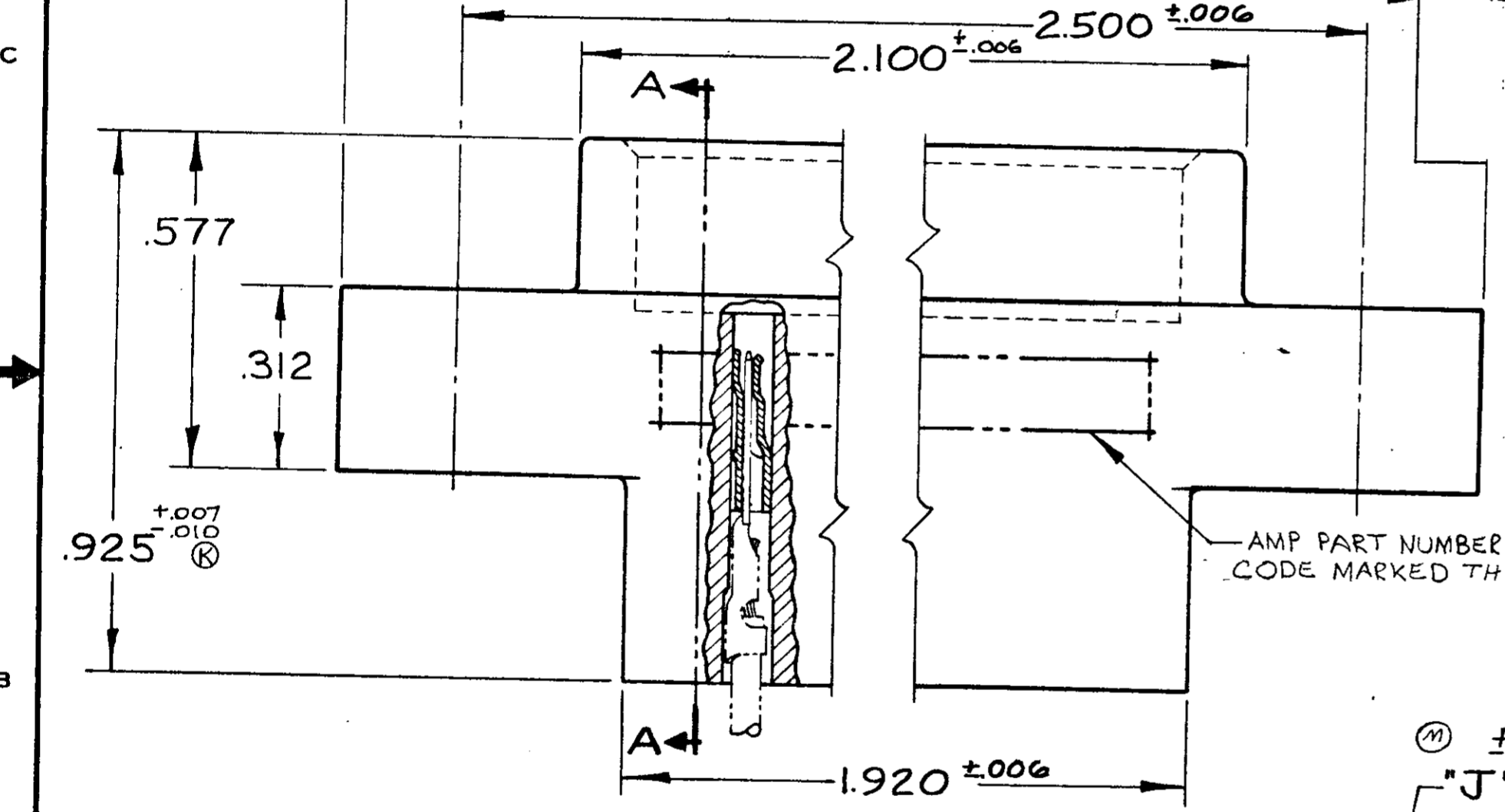

DETAIL "B"

FIT FOR #4-40 SCREW -4 ONLY

CLEARANCE FOR #4-40 SCREW.

±.003 "J" DIA. HOLES

DETAIL "C" -5 ONLY

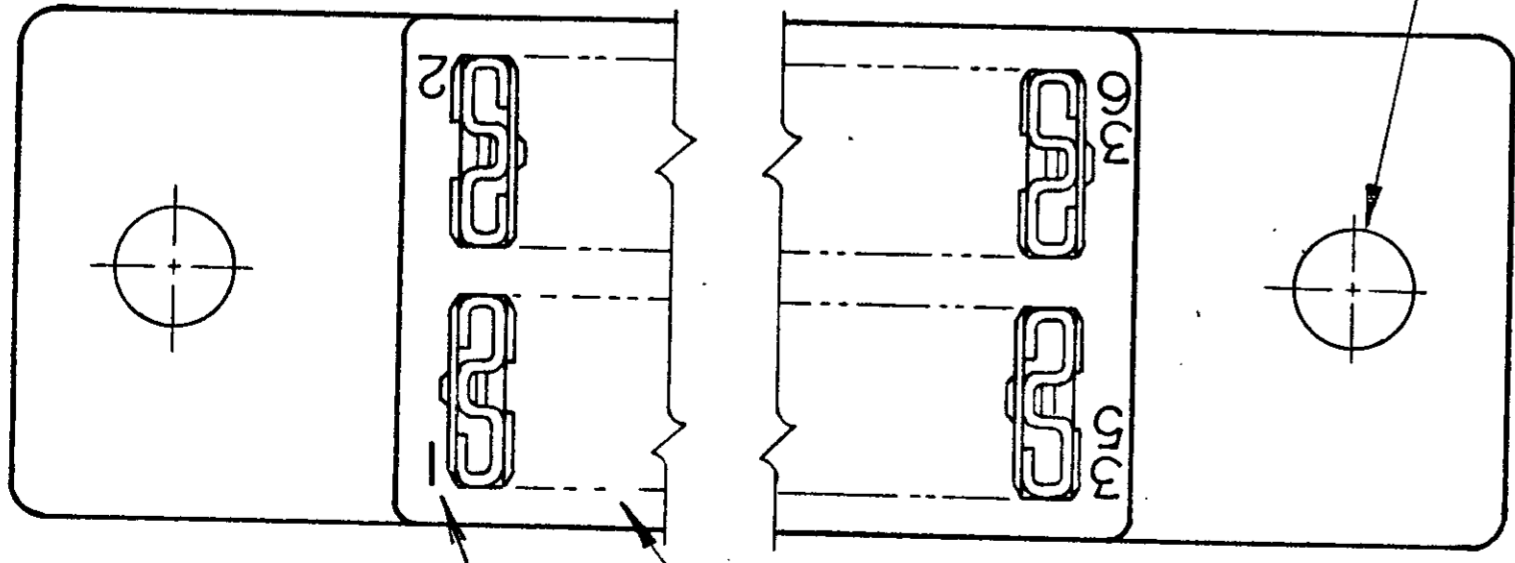

CIRCUIT CAVITY IDENTIFICATION MARKING PER MIL-C-21097 MARK FIRST 5 POSITIONS NEXT 5 POSITIONS PLAIN

3. LASER MARKING ACCEPTABLE FOR ALL MARKING

▲ GROOVES FOR "ON CONTACT KEYING" AMP'S OPTION DEPENDING ON METHOD OF MANUFACTURE. FOR "ON CONTACT" KEYING USE KEYING PLUG P/N 583487-1. (MUST BE ORDERED SEPARATELY.)
 ▲ MOUNTING EAR CONFIGURATION AMP'S OPTION DEPENDS ON METHOD OF MANUFACTURE.

UNLESS OTHERWISE SPECIFIED DIMENSIONS ARE IN INCHES TOLERANCES ON		CONTRACT NO.		AMP INCORPORATED HARRISBURG, PENNSYLVANIA	
FRACTIONS	DECIMALS	DR	DATE	AMP TRADEMARK	
\pm	$\pm .005$	<i>J. Asick</i>	12-16-66	18 POSITION AMP-TAB CONNECTOR .100 CENTERS QUAD.	
ANGLES		CHK	DATE	SIZE	CODE IDENT NO
\pm		<i>W. Burns</i>	1-5-67	C	00779
MATERIAL		DSGN ENGR	DATE	NUMBER	582587
SEE CALLOUT		APPD	DATE	REV	T
HEAT TREAT		<i>S. Kaufman</i>	1-10-67	SCALE	4-1
SEE CALLOUT		DSGN APPD	DATE	WT	CALC
		<i>R. Showman</i>	1/10/67	ACTUAL	SHEET
		OTHER APPD			

NUMBER CUS. 582587