

THIS DRAWING IS UNPUBLISHED. RELEASED FOR PUBLICATION  
 © COPYRIGHT - By - ALL RIGHTS RESERVED.

| LOC | DIST | REVISIONS |     |                           |         |     |      |
|-----|------|-----------|-----|---------------------------|---------|-----|------|
| G   | 14   | P         | LTR | DESCRIPTION               | DATE    | DWN | APVD |
|     |      |           | K2  | REVISED PER ECO-11-004820 | 11MAR11 | RK  | HMR  |

|                                |                                |                                |
|--------------------------------|--------------------------------|--------------------------------|
| <b>AMP</b><br>WIRE RANGE       | Listed<br>FILE E13288          | LR7189<br>Certified            |
| 22-16 AWG<br>SOLID OR STRANDED | 22-16 AWG<br>SOLID OR STRANDED | 22-16 AWG<br>SOLID OR STRANDED |

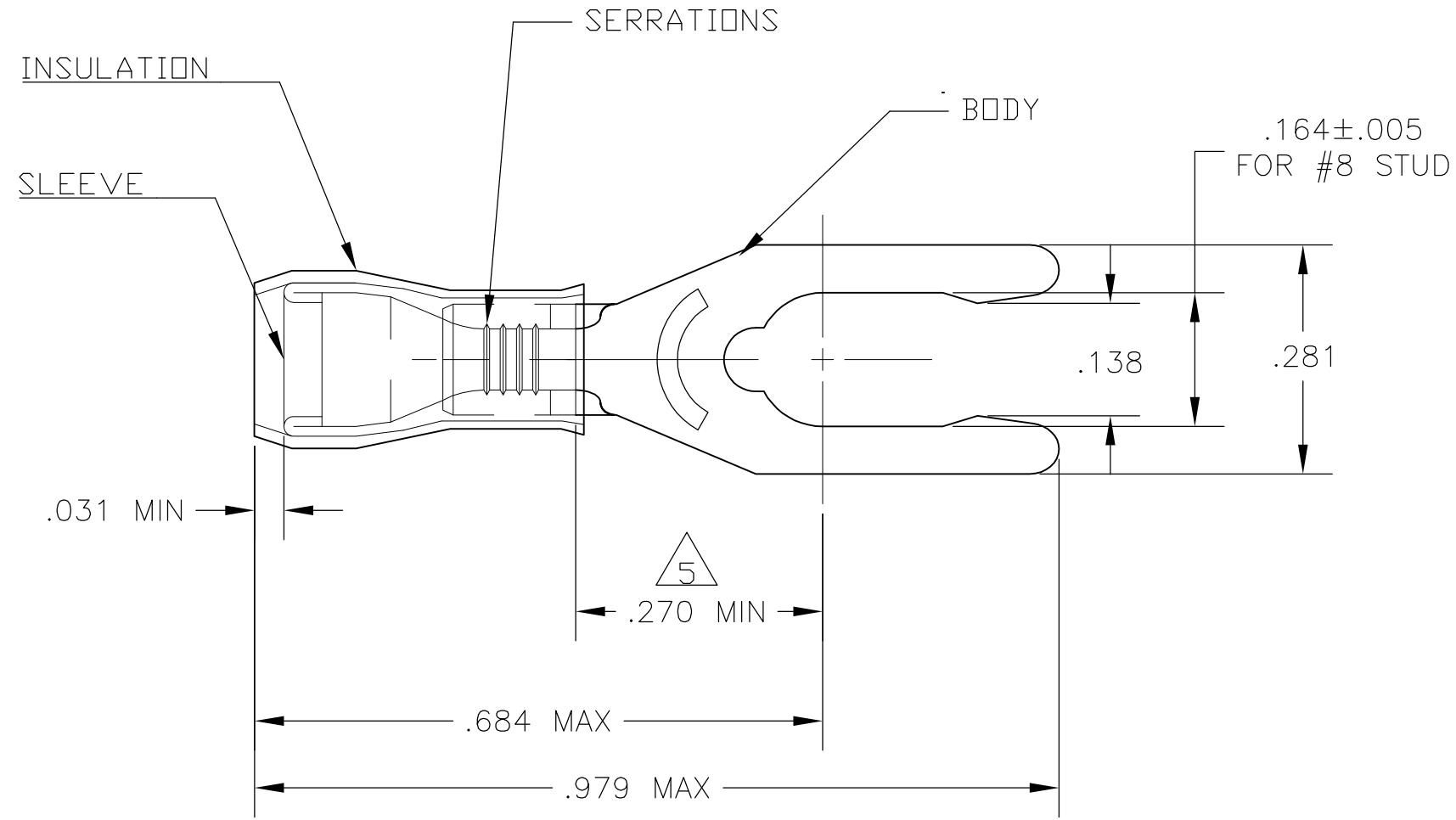

- 1 STAMP AMP 22-18\* APPROX AS SHOWN  
22-16 TERMINALS ARE STAMPED 22-18 IN  
ACCORDANCE WITH MILITARY SPEC MIL-T-7928  
COMMERCIAL WIRE RANGE IS 22-16
- 2 WIRE INSULATION DIA: .080-.125
- 3 TONGUE MATERIAL THK: .031±.002
- 4 MATERIAL: BODY - PHOS BRONZE PER ASTM B103  
TIN PLATE PER ASTM B545  
SLEEVE - CU PER ASTM B152  
TIN PLATE PER ASTM B545  
INSULATION - NYLON, COLOR - SEE TABLE
- 5 APPLIES FROM THE METAL EDGE OF BARREL TO  
CENTERLINE OF STUD.

| RED                 | 100  | LOOSE PIECE,<br>BOX    | 8-52410-1 |
|---------------------|------|------------------------|-----------|
| NATURAL             | 1000 | LOOSE PIECE            | 1-52410-0 |
| RED                 | 5000 | 52410 ON TAPE,<br>REEL | 52410-1   |
| RED                 | 1000 | LOOSE PIECE            | 52410     |
| INSULATION<br>COLOR | QTY  | PACKAGING TYPE         | PART NO.  |

|   |  |  |  |  |                                    |                          |                    |                       |                         |
|---|--|--|--|--|------------------------------------|--------------------------|--------------------|-----------------------|-------------------------|
| <b>CUSTOMER SERVICE SYSTEMS</b>   |  | MAX RECOMMENDED OPERATING<br>TEMPERATURE:<br>105°C [221°F]         | THIS DRAWING IS A CONTROLLED DOCUMENT. |  | DWN<br>JR RUTH<br>10DEC09          | TE Connectivity          |                    |                       |                         |
| FOR ADDITIONAL<br>PRODUCT INFORMATION OR<br>COPIES OF DRAWINGS<br>AND TECHNICAL DOCUMENTS | PRODUCT INFORMATION CENTER<br>1-800-522-6752 | VOLTAGE RATING:<br>300 V MAX                                       | DIMENSIONS:<br>INCHES                  | TOLERANCES UNLESS<br>OTHERWISE SPECIFIED:                                      | CHK<br>TOM MICHIELUTTI<br>10DEC09  |                          |                    |                       | NAME<br>TOM MICHIELUTTI |
| FOR APPLICATION<br>TOOLING INFORMATION  | TOOLING ASSISTANCE CENTER<br>1-800-722-1111  | CIRCULAR MIL AREA:<br>0.26-1.65mm² [509-3260]<br>SOLID OR STRANDED |  | 0 PLC ± -<br>1 PLC ± -<br>2 PLC ± .008<br>3 PLC ± -<br>4 PLC ± -<br>ANGLES ± - | APVD<br>TOM MICHIELUTTI<br>10DEC09 | PRODUCT SPEC<br>108-1034 |                    |                       |                         |
| FOR ORDER ENTRY   | 1-800-526-5142                               |  | MATERIAL                               | FINISH   | APPLICATION SPEC<br>NOT AVAILABLE  | SIZE<br>A3               | CAGE CODE<br>00779 | DRAWING NO<br>C-52410 | RESTRICTED TO<br>-      |
|   |  |  |  |  | CUSTOMER DRAWING                   | SCALE<br>4:1             | SHEET<br>1 OF 1    | REV<br>K2             |                         |