

LOC		DIST		P		F		ZONE		LTR		REVISIONS		DATE	APPD
AF	50											C	REVISED PER 063A-0451-00	24JUL00	MF-KR

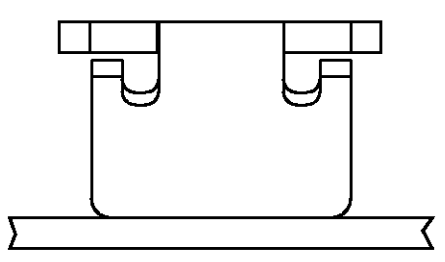

- 1 CONTINUOUS STRIP ON REELS WITH TERMINALS LOCATED ON 5.59±0.08 [.220±.003] CENTERS.
- 2 SLOT ACCEPTS 0.36-0.57mm [#27-#23] AWG COPPER MAGNET WIRE. SINGLE OR DOUBLE WIRE OF THE SAME SIZE AND TYPE.
- 3 REELED ON PLASTIC REELS WITHOUT PAPER.

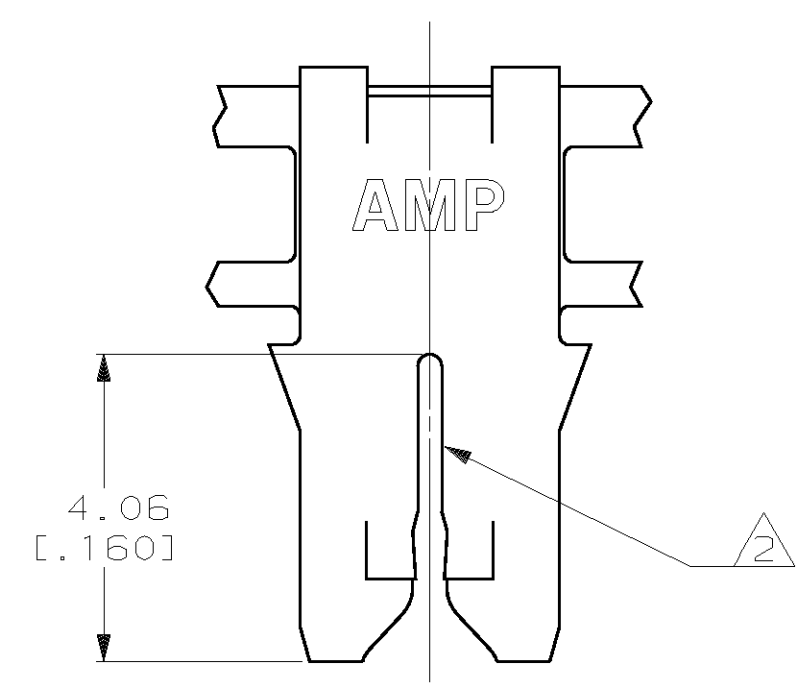
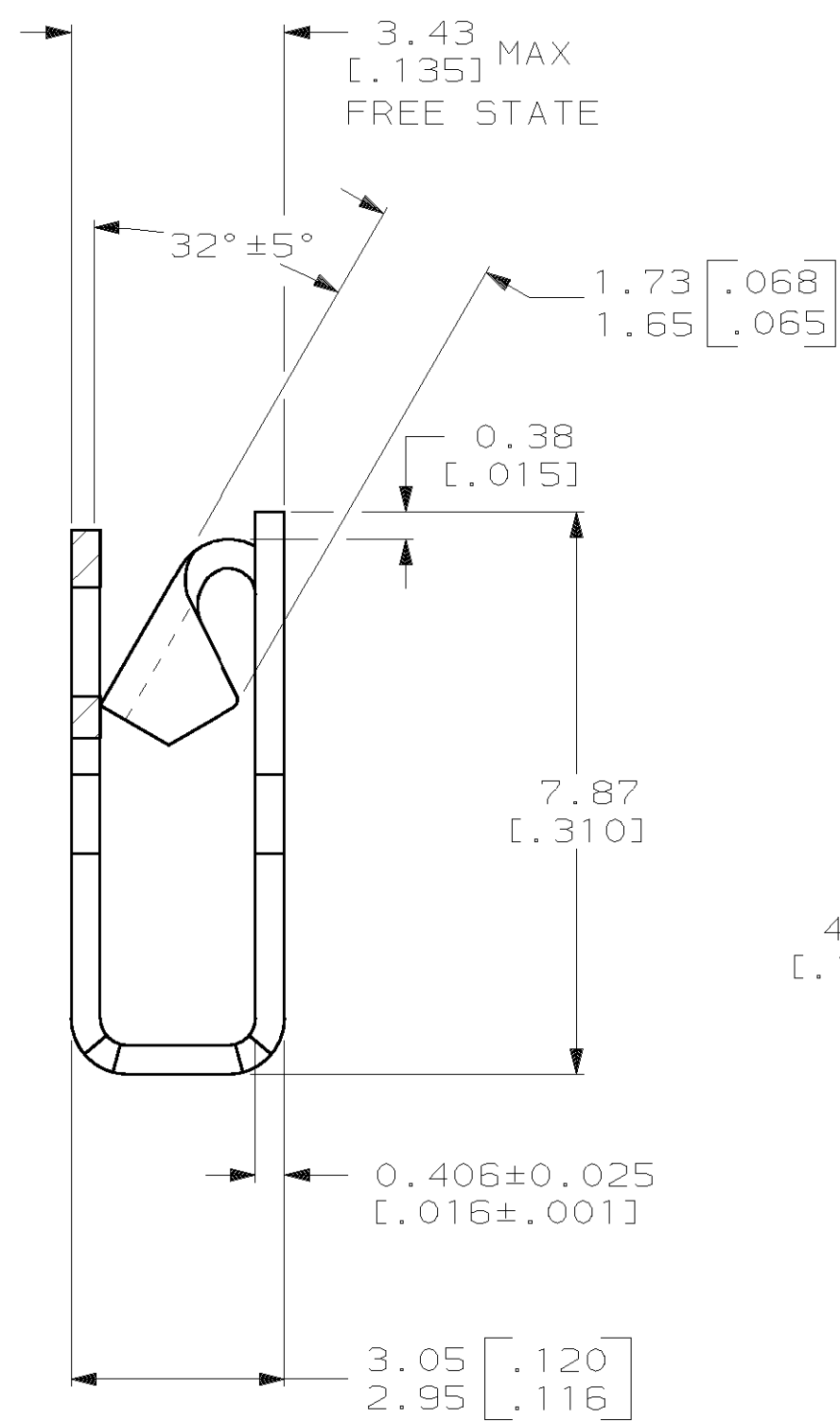
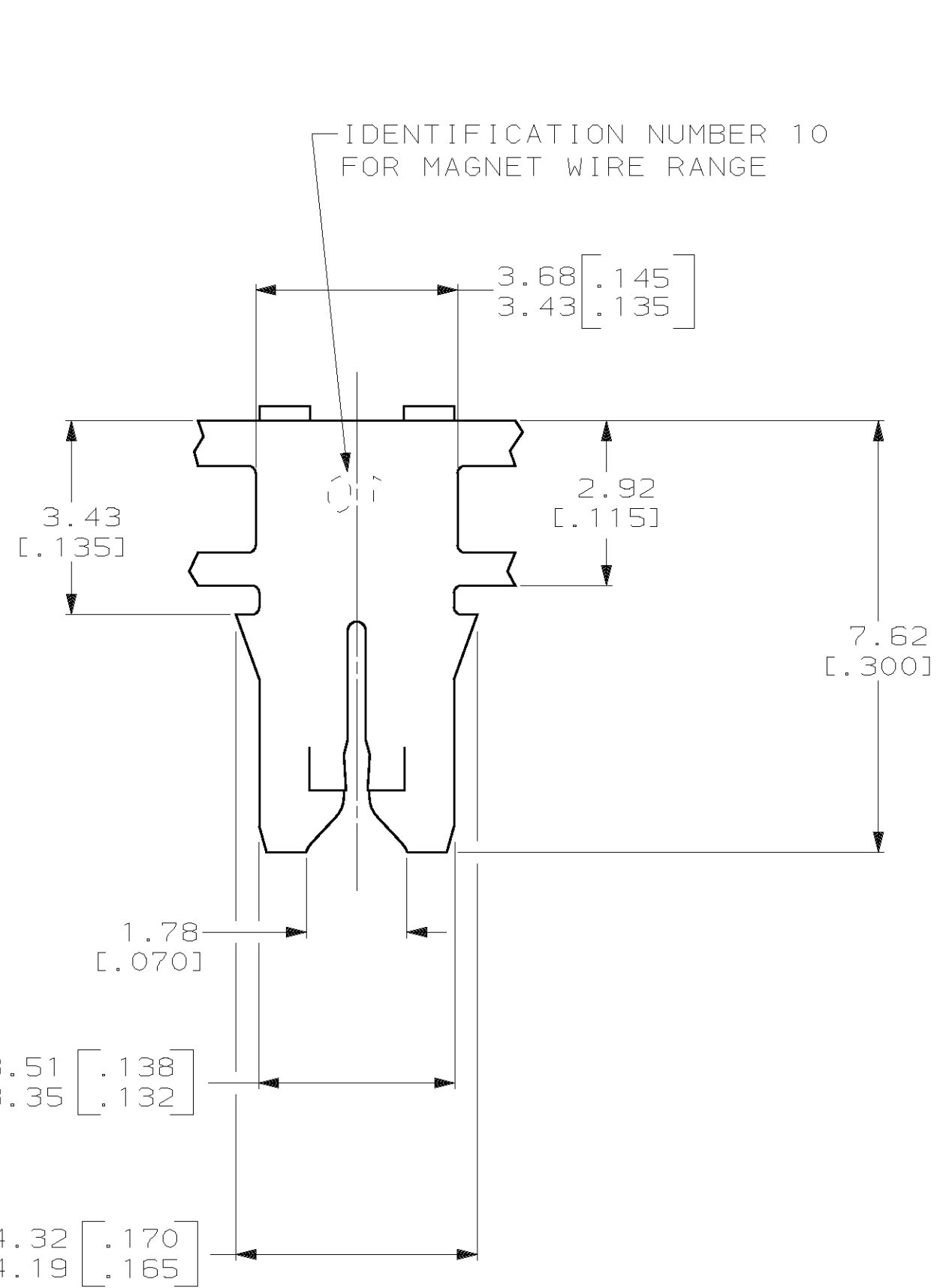

SPLICE FREE	3	63754-1
SPLICE	REELING	PART NO

DO NOT SCALE PRINT. UNLESS SPECIFIED DIMENSIONS IN mm [INCHES] TOLERANCES ON : 2 PLC DEC ± 0.25 [.010] 3 PLC DEC ± - ANGLES ± -	DR 10/22/93 MICHAEL S. FEHER	AMP Incorporated Harrisburg, PA 17105-3608	
	CHK 10/25/93 JEFF R. RUTH		
MATERIAL 4M BRASS	APPD 10/26/93 NELSON E. NEFF	NAME TERMINAL, POKE-IN, 300 SERIES MAG-MATE™	
FINISH 0.002032 [.000080] MIN TIN PLATE	APPD 10/26/93 TERRY L. SHUTTER	PRODUCT SPEC 108-2012	SIZE C
THIS DRAWING IS A CONTROLLED DOCUMENT FOR AMP INCORPORATED. IT IS SUBJECT TO CHANGE AND THE CONTROLLING ENGINEERING ORGANIZATION SHOULD BE CONTACTED FOR THE LATEST REVISION.	APPLICATION SPEC 114-2046	CAGE CODE 00779	DRAWING NO C=63754
	WEIGHT -	SCALE 10:1	SHEET 1 OF 1