

NUMBER 35627

© 1966 BY AMP INCORPORATED. ALL RIGHTS RESERVED. AMP PRODUCTS COVERED BY PATENTS AND/OR PATENTS PENDING.

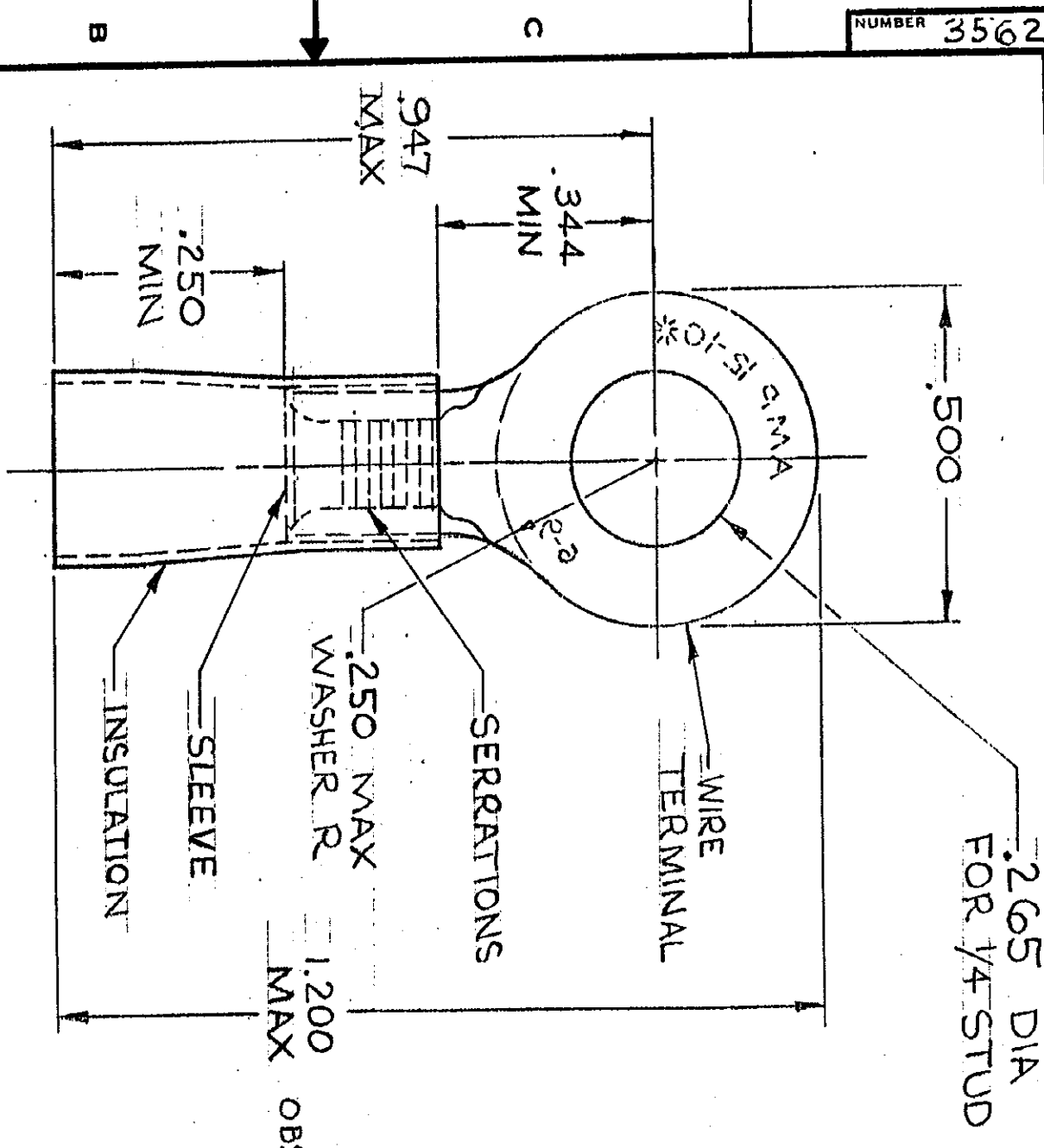

FOR .150 TO .230 WIRE INS. DIA.
TONGUE MATERIAL THK.: .039 ±.002

ZONE	LTR	DESCRIPTION	DATE	APPROVED
A		REDRAWN ADDED 2-35627-1	2-25-66	TC
B		REMOVED 2-35627-1 PER G-1078	4-3-73	RG
C		ADDED TAPE NO. PER P-7000	6-7-73	Shue
D		INACTIVATED 35627 P-7052		
E		REACTIVATED 35627 PER ECN P8704	1-28-82	Jim
F		OES 2--2 G-2407	3-28-87	Jim
G		REV PER G-2541	2-11-87	Jim
		REV/G-005591	7/91	W.D.K.S.

QTY	NOMENCLATURE	PART OR IDENTIFYING NO.	CONTRACT NO.	OTHER INFO
1	WIRE TERMINAL	35627	2-35627-2	35627

INSULATION: PVC
COLOR: BLACK
SLEEVE: COPPER (QQ-C-576) ANNEALED
WIRE TERMINAL: COPPER (QQ-G-576) TIN PL (MIL-T-10727) TYPE I ANNEALED

MATERIAL & FINISH

AMP AMP INCORPORATED
HARRISBURG, PENNSYLVANIA

WIRE TERMINAL
PLASTI-BOND, RING TONGUE
WIRE SIZE: 12-10

SCALE 4:1
WT CALC ACTUAL SHEET 1 OF 1

CUSTOMER DRAWING

AMP INFO
LOC PRINT DIST
FINISH TABLE

HEAT TREAT
OTHER APPD

DESIGN APPD
OTHER APPD

SIZE CODE IDENT NO. NUMBER
B 00779 35627