

THIS DRAWING IS UNPUBLISHED.

RELEASED FOR PUBLICATION

ALL RIGHTS RESERVED.

© COPYRIGHT - By -

| LOC | DIST | REVISIONS   |                           |         |        |
|-----|------|-------------|---------------------------|---------|--------|
| P   | LTR  | DESCRIPTION | DATE                      | DWN     | APVD   |
| AF  | 50   | A1          | REVISED PER ECR-12-007832 | 30APR12 | HMR PD |

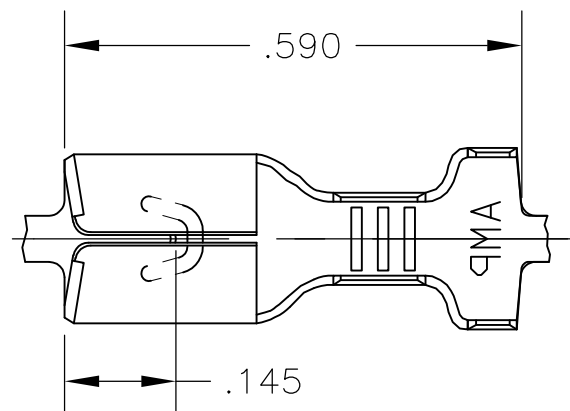

- 1 CONTINUOUS STRIP ON REELS.
- 2 WIRE SIZE #18-#16 OR TWO #18'S AWG
- 3 INSULATION RANGE 2.67-5.33 [.105-.210] DIA OR TWO AT 2.67 MAX [.105] DIA
- 4 MATING TAB THK 0.81±0.025 [.032±.001]

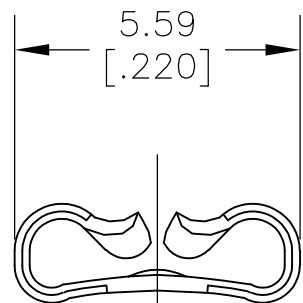

VIEW C-C  
SCALE 8:1

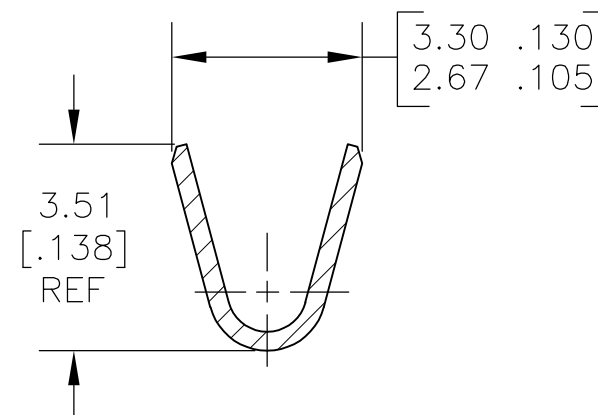
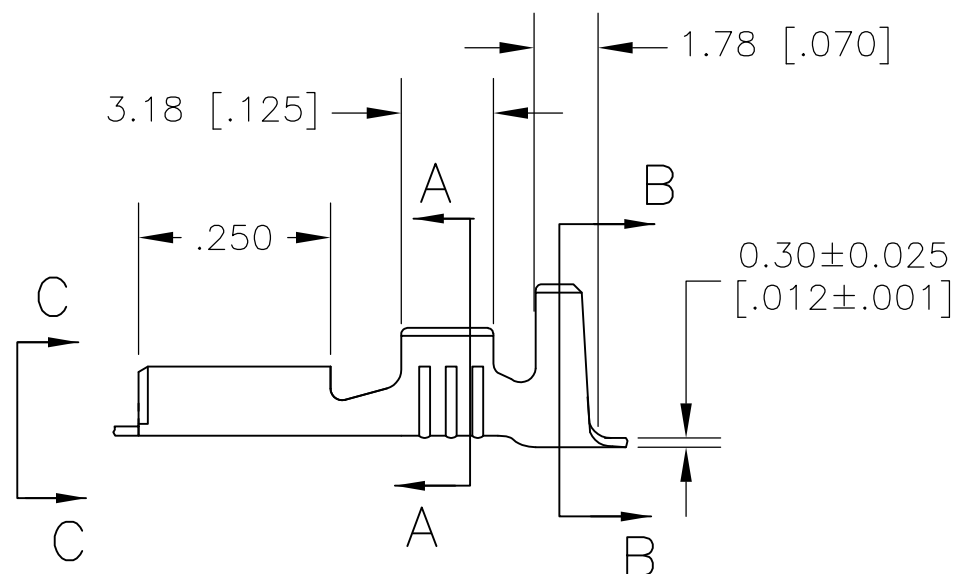

SECTION A-A  
SCALE 8:1

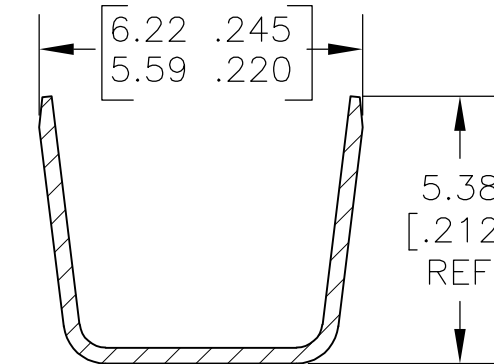

SECTION B-B  
SCALE 8:1

1742899-1

PART NO

|   |               |                                  |  |                    |                         |       |               |       |     |       |     |        |      |                   |            |  |  |
|---|---------------|----------------------------------|--|--------------------|-------------------------|-------|---------------|-------|-----|-------|-----|--------|------|-------------------|------------|--|--|
| THIS DRAWING IS A CONTROLLED DOCUMENT.  |               | DWN<br>jr_ruth<br>15MAY11        |  <b>TE Connectivity</b> |                    |                         |       |               |       |     |       |     |        |      |                   |            |  |  |
| DIMENSIONS:<br>MM [ INCHES ]  |               | CHK<br>PETE_DESANTIS<br>15MAY11  |  |                    |                         |       |               |       |     |       |     |        |      |                   |            |  |  |
| TOLERANCES UNLESS OTHERWISE SPECIFIED:  |               | APVD<br>PETE_DESANTIS<br>15MAY11 | NAME<br>RECEPTACLE , FASTON,<br>.187 SERIES  |                    |                         |       |               |       |     |       |     |        |      |                   |            |  |  |
| <table border="0"> <tr><td>0 PLC</td><td>± -</td></tr> <tr><td>1 PLC</td><td>± -</td></tr> <tr><td>2 PLC</td><td>± 0.25 [.010]</td></tr> <tr><td>3 PLC</td><td>± -</td></tr> <tr><td>4 PLC</td><td>± -</td></tr> <tr><td>ANGLES</td><td>± 5°</td></tr> </table> |               | 0 PLC                            | ± -  | 1 PLC              | ± -                     | 2 PLC | ± 0.25 [.010] | 3 PLC | ± - | 4 PLC | ± - | ANGLES | ± 5° | PRODUCT SPEC<br>- | SIZE<br>A3 |  |  |
| 0 PLC   | ± -           |                                  |  |                    |                         |       |               |       |     |       |     |        |      |                   |            |  |  |
| 1 PLC   | ± -           |                                  |  |                    |                         |       |               |       |     |       |     |        |      |                   |            |  |  |
| 2 PLC   | ± 0.25 [.010] |                                  |  |                    |                         |       |               |       |     |       |     |        |      |                   |            |  |  |
| 3 PLC   | ± -           |                                  |  |                    |                         |       |               |       |     |       |     |        |      |                   |            |  |  |
| 4 PLC   | ± -           |                                  |  |                    |                         |       |               |       |     |       |     |        |      |                   |            |  |  |
| ANGLES  | ± 5°          |                                  |  |                    |                         |       |               |       |     |       |     |        |      |                   |            |  |  |
| MATERIAL<br>CR STEEL  |               | FINISH<br>NICKEL PLATE           | APPLICATION SPEC<br>-  | CAGE CODE<br>00779 | DRAWING NO<br>C-1742899 |       |               |       |     |       |     |        |      |                   |            |  |  |
| CUSTOMER DRAWING  |               |                                  | WEIGHT<br>-  | RESTRICTED TO<br>- | SCALE<br>4:1            |       |               |       |     |       |     |        |      |                   |            |  |  |
|   |               |                                  | SHEET<br>1 OF 1  |                    | REV<br>A1               |       |               |       |     |       |     |        |      |                   |            |  |  |