

RECOMMEND P.C.B. LAND DIM.

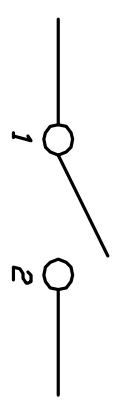
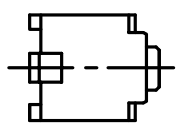
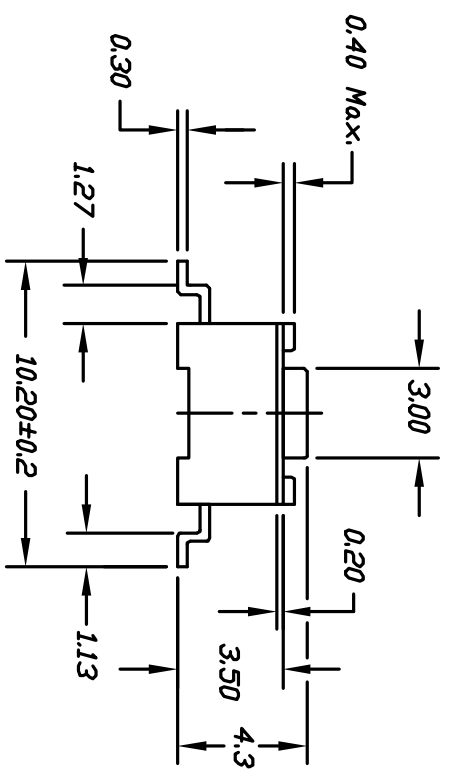

CIRCUIT. SPST

CONTACT CONFIGURATION

NOTES:

1. ALL DIMENSIONS IN MM [IN]
2. TERM. NOS. FOR REF. ONLY
3. RATING: DC 12V, 50mA
4. TRAVEL: 0.25 +0.2/-0.1mm
5. CONTACT RESISTANCE: 100 Ohms Max.

**E-SWITCH®**

TL 3302 A F260 Q G

REVISED & REDRAWN		DATE	CHKD	TITLE	
B				TL 3302 A F260 Q G	
REV.	DESCRIPTION	DATE	CHKD	SCALE	DATE
	THE INFORMATION CONTAINED IN THIS DOCUMENT IS PRELIMINARY TO E-SWITCH AND IS NOT TO BE COPIED OR TRANSMITTED			4:1	10/10/96
				DR	MM
				DWG	P010522
				REV	B
TOLERANCES					
0.0	±0.4				
0.00	±0.25				