

ALUMINUM ELECTROLYTIC CAPACITORS



Chip Type, High Reliability.
Low temperature ESR specification.



For SMD



Long Life



Anti-Solvent Feature

- Chip type, high temperature range, for +125°C use.
- Added ESR specification after the test at -40°C (φ6.3 sizes provide only for the first stage.)
- Applicable to automatic mounting machine fed with carrier tape.
- Compliant to the RoHS directive (2011/65/EU).



Specifications

Item	Performance Characteristics					
Category Temperature Range	-40 to +125°C					
Rated Voltage Range	10 to 50V					
Rated Capacitance Range	10 to 470μF					
Capacitance Tolerance	±20% at 120Hz, 20°C					
Leakage Current	After 1 minute's application of rated voltage, leakage current is not more than 0.03CV or 4(μA), whichever is greater.					
Tangent of loss angle (tan δ)	Measurement frequency : 120Hz at 20°C					
	Rated voltage (V)	10	16	25	35	50
Stability at Low Temperature	Measurement frequency : 120Hz					
	Impedance ratio ZT / Z20 (MAX.)	Z-40°C / Z+20°C	12	8	6	4
Endurance	The specifications listed at right shall be met when the capacitors are restored to 20°C after the rated voltage is applied for 2000 hours at 125°C.					
	Capacitance change	Within ±30% of the initial capacitance value				
Shelf Life	After storing the capacitors under no load at 125°C for 1000 hours and then performing voltage treatment based on JIS C 5101-4 clause 4.1 at 20°C, they shall meet the specified values for the endurance characteristics listed above.					
	tan δ	300% or less than the initial specified value				
Resistance to soldering heat	The capacitors are kept on a hot plate for 30 seconds, which is maintained at 250°C. The capacitors shall meet the characteristic requirements listed at right when they are removed from the plate and restored to 20°C.					
	Leakage current	Less than or equal to the initial specified value				
Marking	Black print on the case top.					

Chip Type

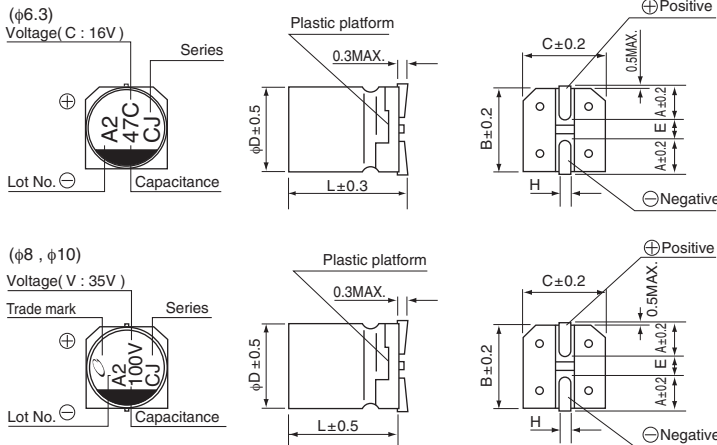

Type numbering system (Example : 10V 100μF)

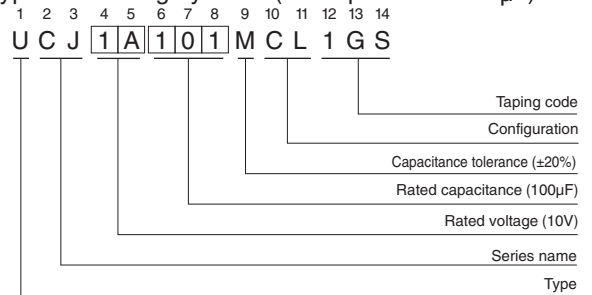

φD×L	6.3×8.7	8×10	10×10
A	2.4	2.9	3.2
B	6.6	8.3	10.3
C	6.6	8.3	10.3
E	2.2	3.1	4.5
L	8.7	10	10
H	0.5 to 0.8	0.8 to 1.1	0.8 to 1.1

Rated Voltage						
V	10	16	25	35	50	
Code	A	C	E	V	H	

Dimensions

Cap.(μF)	Code	10			16			25			35			50							
		1A			1C			1E			1V			1H							
10	100										6.3×8.7	14	-	95	6.3×8.7	14	-	95			
22	220							6.3×8.7	14	-	95	6.3×8.7	14	-	95	6.3×8.7	14	-	95		
33	330							6.3×8.7	14	-	95	6.3×8.7	14	-	95	8×10	2.0	6.0	200		
47	470				6.3×8.7	14	-	95	6.3×8.7	14	-	95	6.3×8.7	14	-	95	10×10	1.5	4.5	330	
100	101	6.3×8.7	14	-	95	8×10	2.0	6.0	250	8×10	2.0	6.0	250	10×10	1.5	4.5	400	10×10	1.5	4.5	330
220	221	8×10	2.0	6.0	250	10×10	1.5	4.5	400	10×10	1.5	4.5	400	10×10	1.5	4.5	400	Case size φD×L (mm)	Initial ESR	after endurance test	Rated ripple
330	331	10×10	1.5	4.5	400	10×10	1.5	4.5	400	10×10	1.5	4.5	400								
470	471	10×10	1.5	4.5	400																

Frequency coefficient of rated ripple current

Frequency	50 Hz	120 Hz	300 Hz	1 kHz	10 kHz or more
Coefficient	0.35	0.50	0.64	0.83	1.00

Max. ESR (Ω) at -40°C 100kHz, Rated ripple current (mArms) at 125°C 100kHz

- Taping specifications are given in page 23.
- Recommended land size, soldering by reflow are given in page 18, 19.
- Please refer to page 3 for the minimum order quantity.