

# MPS SERIES (PGR-6300)

## Motor Protection System

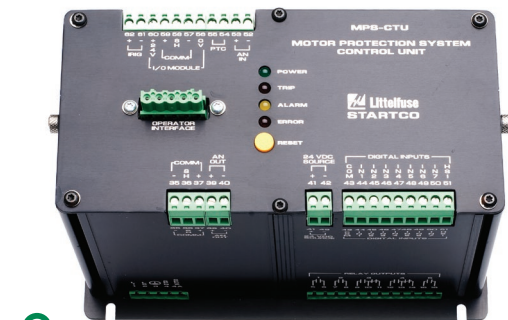
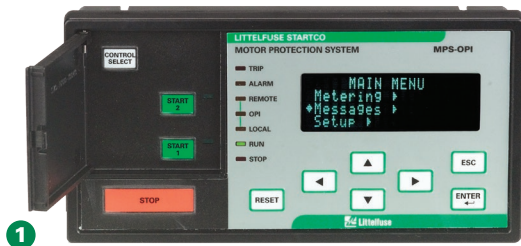

### Description

The MPS Motor Protection System monitors voltage, current, and temperature to provide a comprehensive package of 22 protective functions. The MPS is a modular system with integrated protection, motor control, metering, and data-logging functions. This system is typically used to provide protection for three-phase low- and medium-voltage, medium- to high-horsepower induction motors.

#### 1 Operator Interface (MPS-OPI)

- Large, bright, 4 x 20 vacuum-fluorescent display
- Display metered values
- Access set points
- Powered by Control Unit
- Panel mount or attach directly to Control Unit
- Remote mounting (1.2 km or 4000 ft maximum loop length)
- 1/2 DIN size
- Hazardous-location certified

#### 2 Control Unit (MPS-CTU)

- Current inputs—5-A or 1-A secondary phase current transformers
- Voltage inputs—up to 600 V without PTs
- Earth-leakage input—5-A or 1-A secondary or sensitive transformer
- Tachometer (high-speed pulse) input
- 8 digital inputs, 5 relay outputs, 1 analog input and output
- 24-Vdc supply for OPI and RTD modules, and for digital inputs
- IRIG-B time-code input
- 1/2 DIN size, surface mount
- RS-485 network communications (Standard)
- DeviceNet™, Profibus®, or Ethernet communications available

### Simplified Circuit Diagram

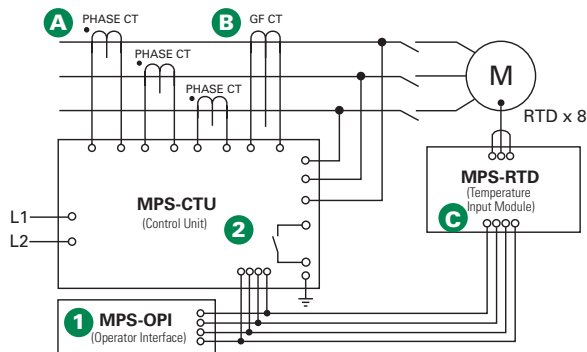

### Accessories



#### Phase Current Transformers

Phase CTs are required to detect phase currents.

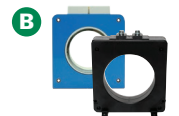

#### Ground-Fault Current Transformer

Required zero-sequence current transformer detects ground-fault current. Available with 5-A and 30-A primary ratings for low-level pickup.



#### MPS-RTD Temperature Input Module

Optional module provides 8 inputs to connect Pt100, Ni100, Ni120, and Cu10 RTDs.



#### MPS-DIF Differential Current Module

Optional motor differential protection, compatible with core balance and summation current transformer connections.

### Ordering Information

ORDERING NUMBER	COMMUNICATIONS
MPS-CTU-01-00	RS-485
MPS-CTU-02-00	RS-485 & DeviceNet™
MPS-CTU-03-00	RS-485 & Profibus®
MPS-CTU-04-00	RS-485 & EtherNet/IP™ & Modbus® TCP

ACCESSORIES	REQUIREMENT
MPS-OPI-01-00	Recommended
Phase CTs	Required
Ground-Fault CT	Recommended
MPS-RTD-01-00	Optional
MPS-DIF-01-00	Optional
SE-IP65CVR-M	Optional

# MPS SERIES (PGR-6300)

## Motor Protection System

### Features & Benefits

FEATURES	IEEE #	BENEFITS
<b>Overload</b>	49, 51	Extends motor life and prevents insulation failures and fires
<b>Current unbalance/ Phase loss/Phase reverse</b>	46	Prevents overheating and extends motor life
<b>Overcurrent/Jam</b>	50, 51	Prevents catastrophic failures and fires and extends motor life
<b>Undercurrent</b>	37	Detects low-level or no-load conditions
<b>Ground fault</b>	50G/N, 51G/N	Prevents catastrophic failures and fires
<b>RTD temperature</b>	38, 49	Optional RTD temperature protection (MPS-RTD module) for high ambient or loss of ventilation protection
<b>Overvoltage</b>	59	Prevents stress to insulation
<b>Undervoltage</b>	27	Prevents a start attempt when it will damage the motor
<b>Voltage unbalance</b>	47	Detects unhealthy supply voltage
<b>Phase differential</b>	87	Provides sensitive protection for high-resistance winding faults
<b>Dynamic thermal mode</b>		Provides protection through starting, running, overload, and cooling cycles
<b>Reduced overcurrent mode</b>		Minimizes Arc-Flash hazards during maintenance
<b>Starter control</b>		Simplifies the installation by reducing component count
<b>Metering</b>		Displays the measured and calculated motor parameters
<b>Data logging</b>		On-board 64-event recorder helps with system diagnosis
<b>Communications</b>		Remotely view measured values, event records & reset trips
<b>Conformal coating</b>		Internal circuits are conformally coated to protect against corrosion and moisture

### Wiring Diagram

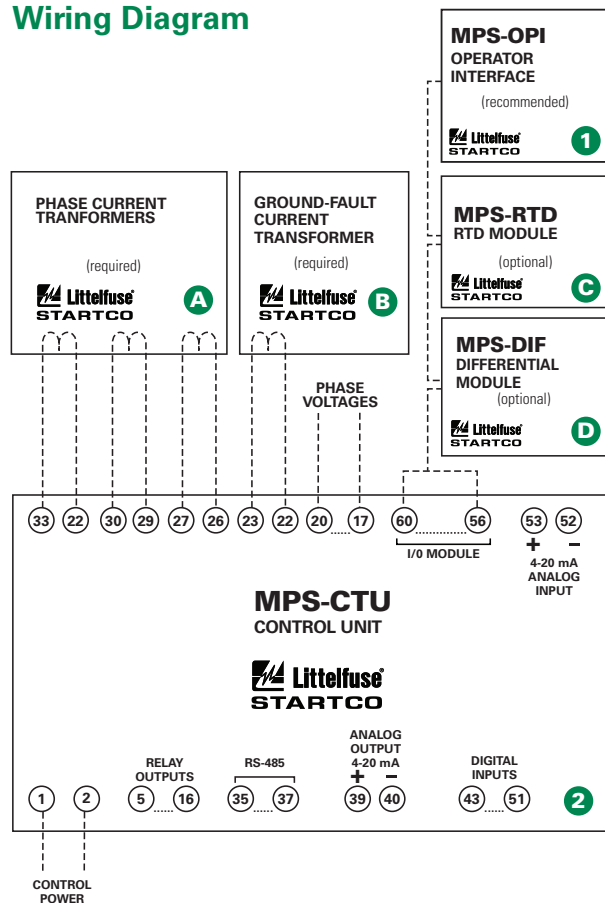

### Specifications

<b>Protective Functions (IEEE Device Numbers)</b>	Overload (49, 51)	Unbalance (current) (46)
	Phase reverse (current) (46)	Underspeed (14)
	Overfrequency (81)	Starts per hour (66)
	Overcurrent (50, 51)	Phase loss (voltage) (47)
	Jam	Overvoltage (59)
	Underfrequency (81)	Differential (87)
	Ground fault (50G/N, 51G/N)	Phase loss (current) (46)
	Undercurrent (37)	Undervoltage (27)
	Unbalance (voltage) (47)	Phase reverse (voltage) (47)
	Failure to accelerate	Power factor (55)
RTD temperature (38, 49)		
<b>Input Voltage</b>	65-265 Vac, 25 VA; 80-275 Vdc, 25 W	
<b>Power-Up Time</b>	800 ms at 120 Vac	
<b>Ride-Through Time</b>	100 ms minimum	
<b>24-Vdc Source</b>	100 mA maximum	
<b>AC Measurements</b>	True RMS and DFT, Peak, 16 samples/cycle, and positive and negative sequence of fundamental 50, 60 Hz or ASD	
<b>Frequency Inputs</b>	Phase current, Earth-leakage current, Phase voltage, 7 digital, tachometer, 1 analog	
<b>Output Contacts</b>	5 contacts — See Product Manual	
<b>Approvals</b>	CSA Certified, RCM (Australian), UL Recognized	
<b>Communications</b>	Allen-Bradley® DFI and Modbus® RTU (Standard); DeviceNet™, Profibus®, Ethernet (Optional)	
<b>Conformally Coated</b>	Standard feature	
<b>Warranty</b>	10 years	
<b>Mounting (Control Unit)</b>	Surface	
<b>Mounting (Operator Interface)</b>	Panel, Control-Unit mounted	