

DRAWING MADE IN THIRD ANGLE PROJECTION

THIS DRAWING IS UNPUBLISHED. RELEASED FOR PUBLICATION, 19 .
 © COPYRIGHT 19 BY AMP INCORPORATED, HARRISBURG, PA. ALL INTERNATIONAL RIGHTS RESERVED. AMP PRODUCTS MAY BE COVERED BY U.S. AND FOREIGN PATENTS AND/OR PATENTS PENDING.

LOC DIST
 AF 50

P		F		ZONE		LTR		REVISIONS		
								DESCRIPTION	DATE	APPROVED
							B	REV & REDRAWN AF-5094	1/20/88	MSF

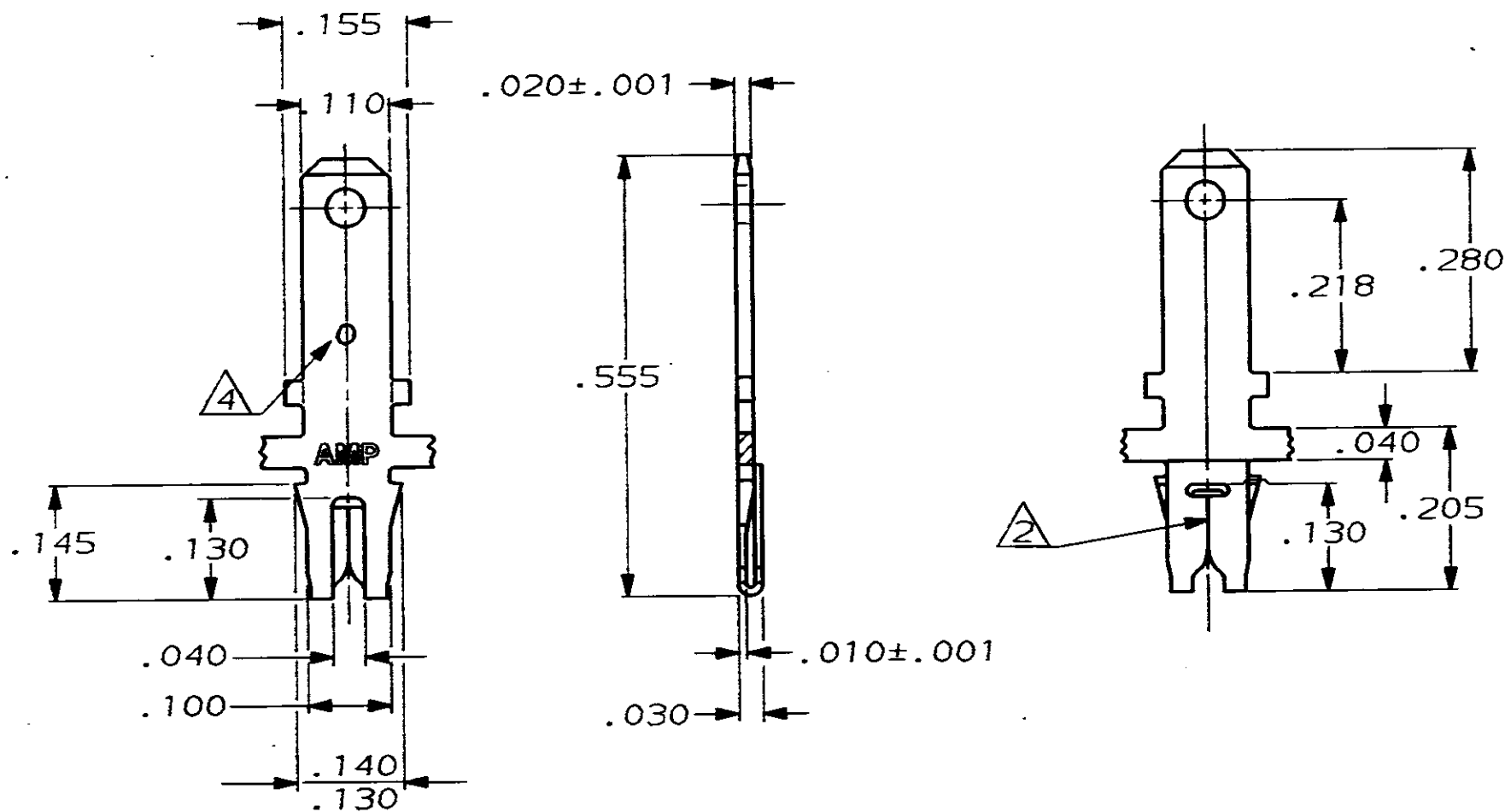

- CONTINUOUS STRIP ON REELS WITH TERMINALS LOCATED ON .220 CENTERS.
- SLOT TO ACCEPT A #34-#32 COPPER MAGNET WIRE ONLY.
- AFTER INSERTION INTO PLASTIC HOLDER, TAB PORTION MUST BE BENT OVER 45° TO 90° OR POTTED TO PREVENT PULL-OUT WHEN MATING RECEPTACLE IS DISCONNECTED.
- IDENTIFICATION NUMBER FOR MAGNET WIRE RANGE.
- MAG-MATE CAVITY SPECIFICATION.

63441-1

PART NO

UNLESS OTHERWISE SPECIFIED DIMENSIONS ARE IN INCHES
 TOLERANCES ON:
 2 PL DEC ± -
 3 PL DEC ± .010
 ANGLES ± -

MATERIAL
 #4 HARD BRASS

FINISH
 TIN

DR: MSF 1/20/88

CHK: G Yetton 1/22/88

APP'D: [Signature] 1/20/88

PRODUCT SPEC

APPLICATION SPEC
 114-2099 5

WEIGHT -

AMP AMP INCORPORATED
 Harrisburg, Pa. 17105

NAME
 TAB, .110 FASTON,
 MAG-MATE™, MICRO

SIZE: **B** FSCM NO: 00779 DRAWING NO: 63441

SCALE: 5:1 SHEET: 1 OF 1