

4

3

2

1

THIS DRAWING IS UNPUBLISHED. RELEASED FOR PUBLICATION ,19 .
 © COPYRIGHT 19 BY AMP INCORPORATED. ALL RIGHTS RESERVED.

LOC	DIST	REVISIONS					
		P	LTR	DESCRIPTION	DATE	DWN	APVD
G	86		C	REVISED PER 0L20-0260-97	22DEC97	DKS	MJS

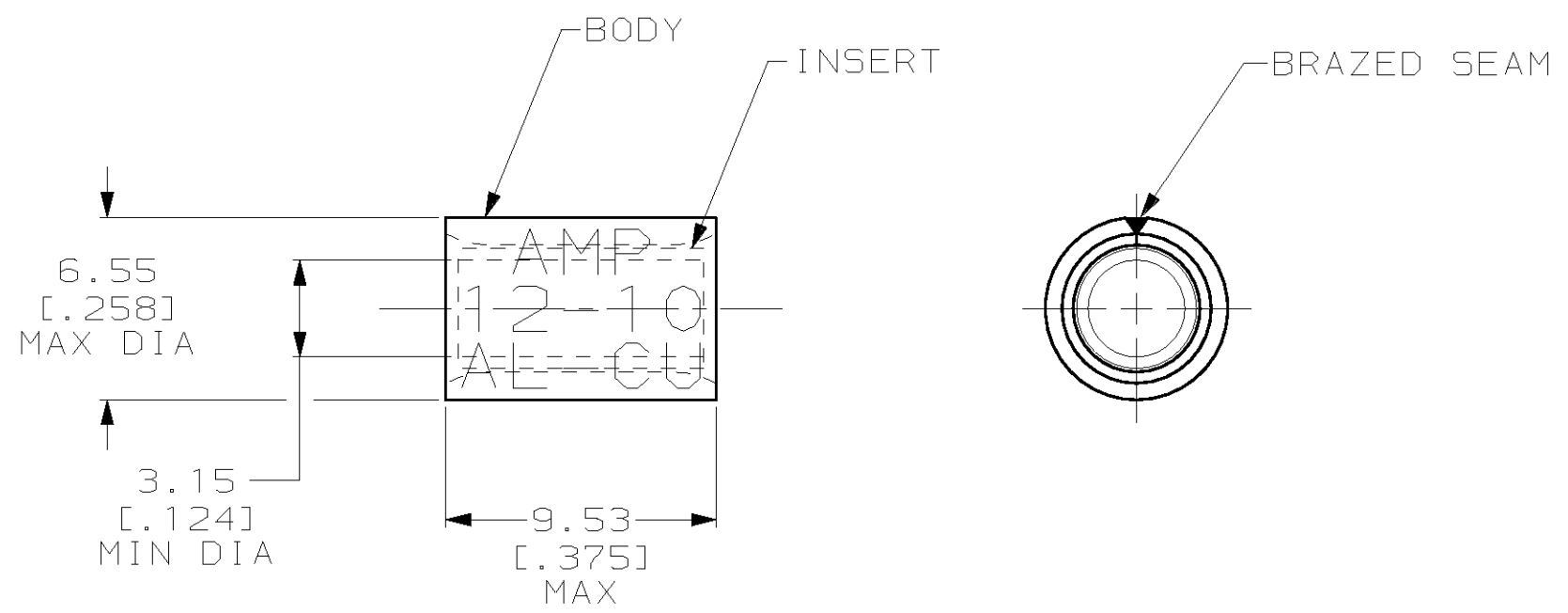

<u>BODY:</u> COPPER PER ASTM B-152 TIN PL 0.00254 [.000100] MIN THK PER ASTM B-545	52792
<u>INSERT:</u> BRASS PER MIL-C-50 TIN PL 0.00254 [.000100] MIN THK PER ASTM B-545	
MATERIAL & FINISH	AMP PART NUMBER

AMP INCORPORATED CUSTOMER SERVICE SYSTEMS

FOR ADDITIONAL PRODUCT INFORMATION OR COPIES OF DRAWINGS AND TECHNICAL DOCUMENTS	PRODUCT INFORMATION CENTER 1-800-522-6752	RECOMMENDED OPERATING TEMPERATURE: 170°C MAX
FOR APPLICATION TOOLING INFORMATION	TOOLING ASSISTANCE CENTER 1-800-722-1111	VOLTAGE RATING: NOT APPLICABLE
FOR ORDER ENTRY	1-800-526-5142	WIRE CROSS SECTIONAL AREA RANGE: 2.62-6.64mm ² [5,180-13,100] CIR MILS SOLID/STRANDED

THIS DRAWING IS A CONTROLLED DOCUMENT.

DIMENSIONS: mm [INCHES]	TOLERANCES UNLESS OTHERWISE SPECIFIED:
	0 PLC ±-
	1 PLC ±-
	2 PLC ±0.20 [.008]
	3 PLC ±-
	4 PLC ±-
	ANGLES ±5°
MATERIAL SEE TABLE	FINISH SEE TABLE

DWN DK SCHRUM 22DEC97	AMP AMP Incorporated Harrisburg, PA 17105-3608
CHK MJ SPICER 23DEC97	
APVD JL MECKLEY 23DEC97	
PRODUCT SPEC -	NAME SPLICE, PARALLEL, STRANDED/SOLID, COPALUM™, WIRE SIZE: 12-10 AWG
APPLICATION SPEC -	SIZE A3
WEIGHT -	CAGE CODE 00779
CUSTOMER DRAWING	DRAWING NO C- 52792
	RESTRICTED TO -
	SCALE 4:1
	SHEET 1 OF 1
	REV C