

4 3 2 1

DRAWING MADE IN THIRD ANGLE PROJECTION
 THIS DRAWING IS UNPUBLISHED. RELEASED FOR PUBLICATION, 19
 © COPYRIGHT 19 BY AMP INCORPORATED. ALL INTERNATIONAL RIGHTS RESERVED.

LOC	DIST	P	F	ZONE	LTR	REVISIONS	DATE	APPD
G	14				B	REV & REDRAWN PER 0720-0061-93	4-15-93	JSD

METRIC
 DIMENSIONS LISTED IN mm [INCHES]

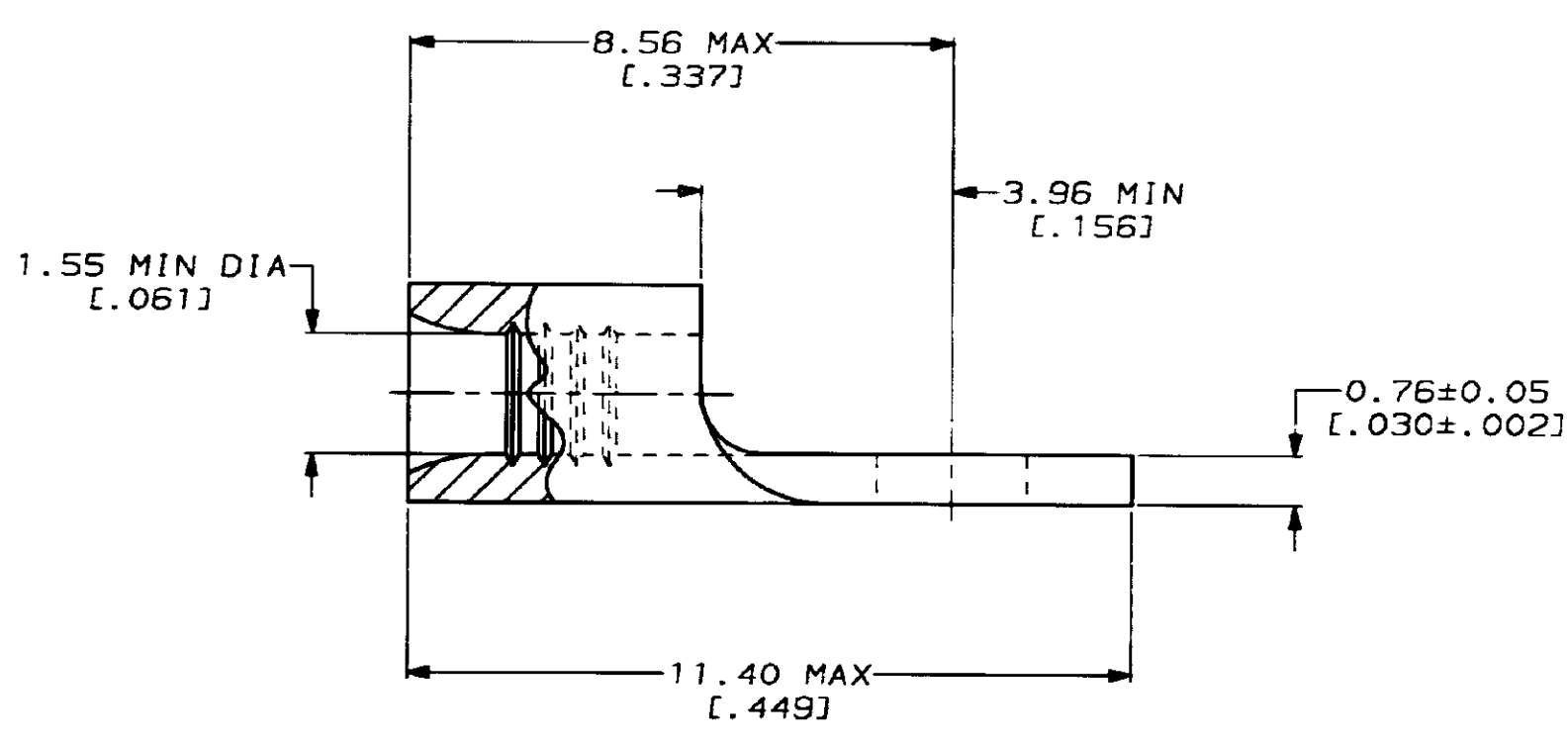
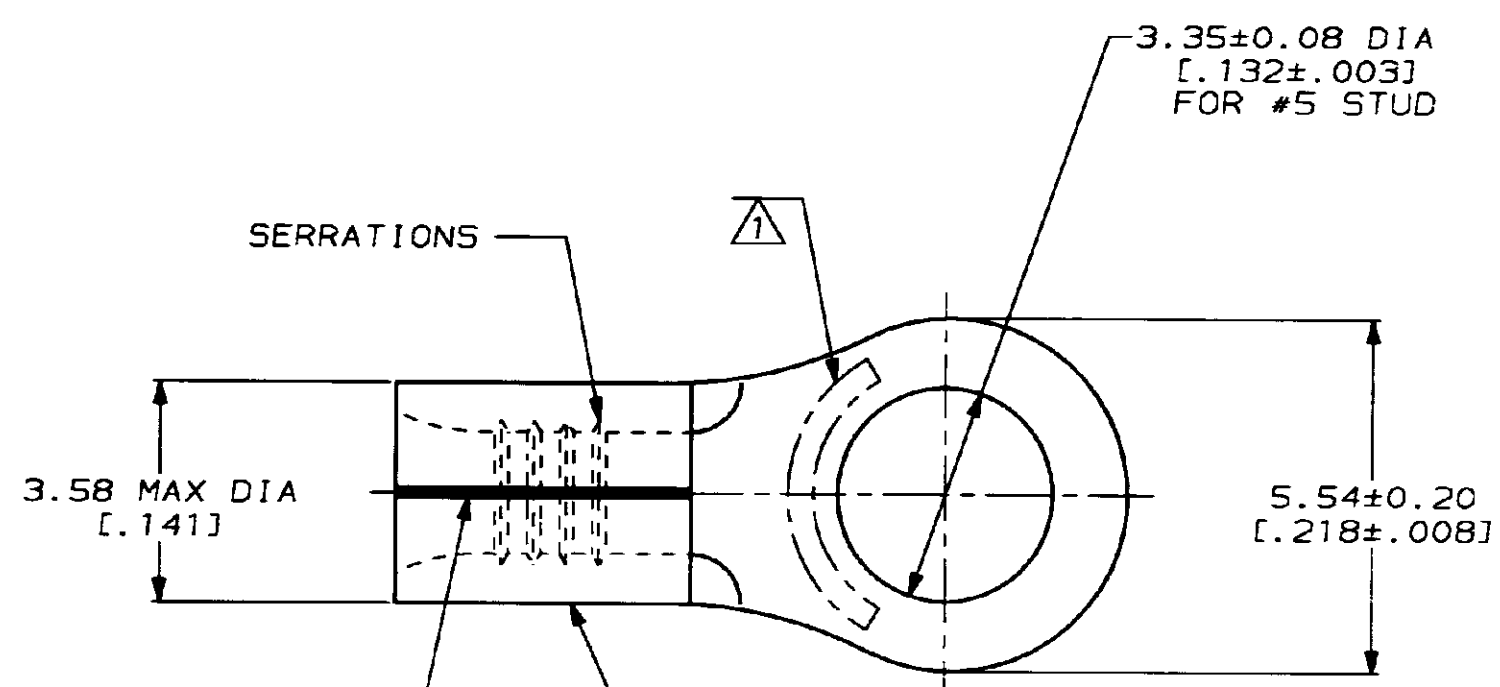

AMP WIRE RANGE	UL E13288 Listed
22-16 AWG SOLID OR STRANDED	NOT APPLICABLE
LR7189 Certified	MILITARY P/N AND CLASS
NOT APPLICABLE	NOT APPLICABLE

- ⚠ STAMP AMP 22-18 APPROX AS SHOWN
22-16 TERMINALS ARE STAMPED 22-18 IN ACCORDANCE WITH MILITARY SPECIFICATION MIL-T-7928, COMMERCIAL WIRE RANGE IS 22-16
- ⚠ WIRE BARREL COLOR CODED ORANGE TO DENOTE NICKEL MATERIAL

AMP INCORPORATED CUSTOMER SERVICE SYSTEMS		MAX RECOMMENDED OPERATING TEMPERATURE: 649°C MAX	DO NOT SCALE PRINT. UNLESS SPECIFIED DIMENSIONS IN mm (INCHES) TOLERANCES ON: 2 PLC DEC ± - 3 PLC DEC ± - ANGLES ± -	DR 4-15-93 TA BRINKMAN	AMP AMP Incorporated Harrisburg, PA 17105-3608	
FOR ADDITIONAL PRODUCT INFORMATION OR COPIES OF DRAWINGS AND TECHNICAL DOCUMENTS	PRODUCT INFORMATION CENTER 1-800-522-6752	VOLTAGE RATING: NOT APPLICABLE	MATERIAL NICKEL PER ASTM B-162 ANNEALED	CHK 4-15-93 DA PATTERSON		NAME TERMINAL, RING TONGUE, HIGH TEMPERATURE, STRATO-THERM™
FOR APPLICATION TOOLING INFORMATION	TOOLING ASSISTANCE CENTER 1-800-722-1111	WIRE CROSS SECTIONAL AREA RANGE: 0.26-1.65mm² [509-3,260] CIR MILS SOLID OR STRANDED	FINISH -	APPD 4-15-93 DE MILLER		
FOR ORDER ENTRY	1-800-526-5142	THIS DRAWING IS A CONTROLLED DOCUMENT FOR AMP INCORPORATED. IT IS SUBJECT TO CHANGE AND THE CONTROLLING ENGINEERING ORGANIZATION SHOULD BE CONTACTED FOR THE LATEST REVISION.		APPD 4-15-93 JL MECKLEY		PRODUCT SPEC -
				APPLICATION SPEC -	SIZE C 00779	
				WEIGHT -	CAGE CODE C-321885	
					DRAWING NO C-321885	
					SCALE 10:1	
					SHEET 1 OF 1	