

△ Unified screw thread type

A(10:1)

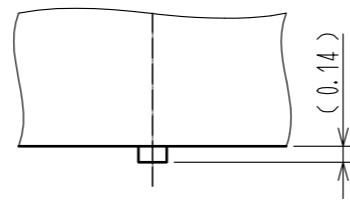

- NOTES
- ① WHEN THE MATING CONNECTOR, PLEASE HOLD MILLING AREA OF 5.8 ± 0.2 WITH A WRENCH.
 - ② 0-80UNF-2B SCREW TIGHTENING TORQUE IS $0.09N \cdot m$.
 - ③ PLEASE USE A PCB MOUNTING SCREW OF THE LENGTH OF L(mm).
THE LENGTH OF L(mm) IS PCB THICKNESS t1(mm) + SPRING WASHER THICKNESS t2(mm) + 2(mm).
PLEASE USE A SCREW WITH SPRING WASHER.

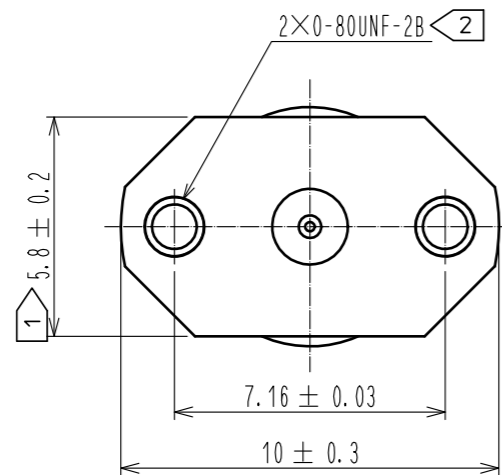
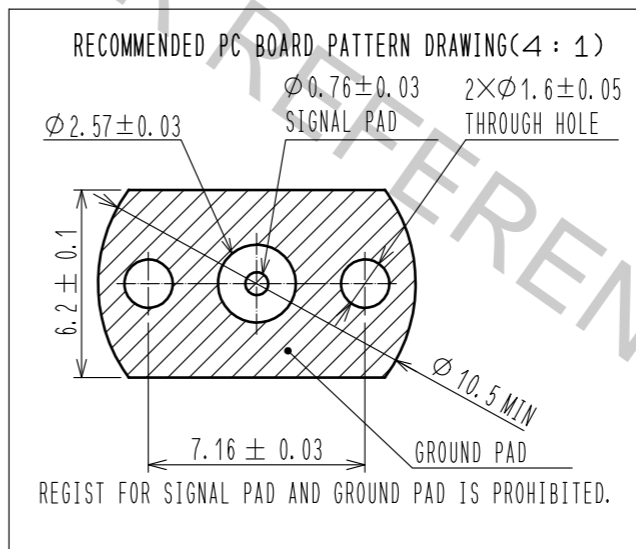
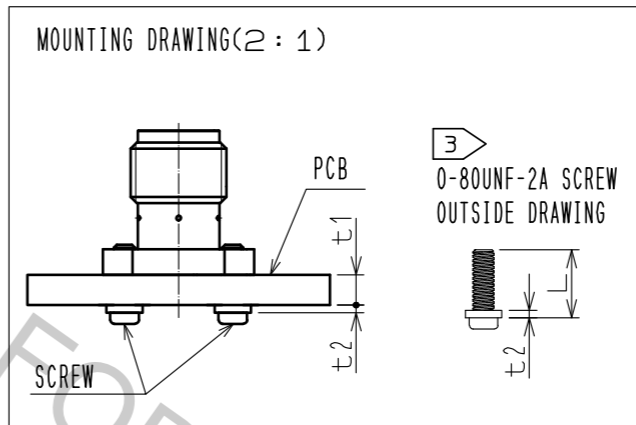
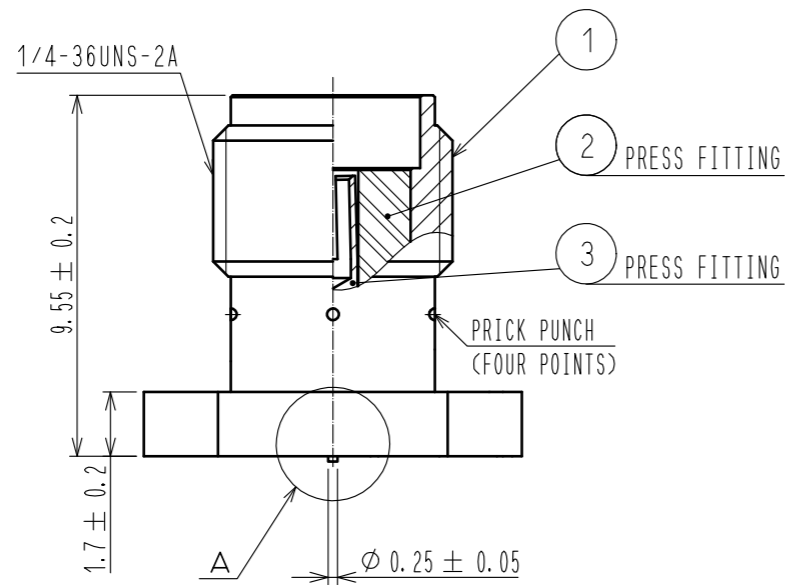
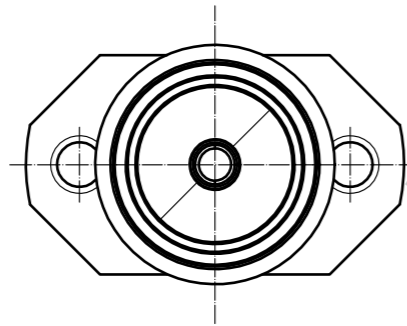

RoHS COMPLIANT

2	PTFE							
1	BRASS	GOLD PLATING		3	BERYLLIUM COPPER	GOLD PLATING		
NO.	MATERIAL	FINISH .	REMARKS	NO.	MATERIAL	FINISH .	REMARKS	
UNITS mm		SCALE 5 : 1	COUNT 2	DESCRIPTION OF REVISIONS DIS-D-00001227		DESIGNED YI. FUNADA	CHECKED MH. TSUCHIDA	DATE 16.06.03
HRS HIROSE ELECTRIC CO., LTD.		APPROVED : MH. YAMANE	12.02.10	DRAWING NO. EDC3-339103-00				
		CHECKED : MH. TSUCHIDA	12.02.10	PART NO. HRMCG)-300-468B-1				
		DESIGNED : RO. YOKOYAMA	12.02.10	CODE NO. CL323-0924-8-00				
		DRAWN : RO. YOKOYAMA	12.02.10					