

**\*\*\*NOTE: INSULATOR DESIGN CHANGE\*\*\***

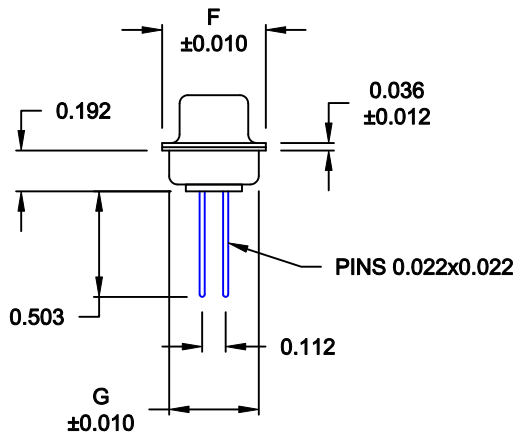
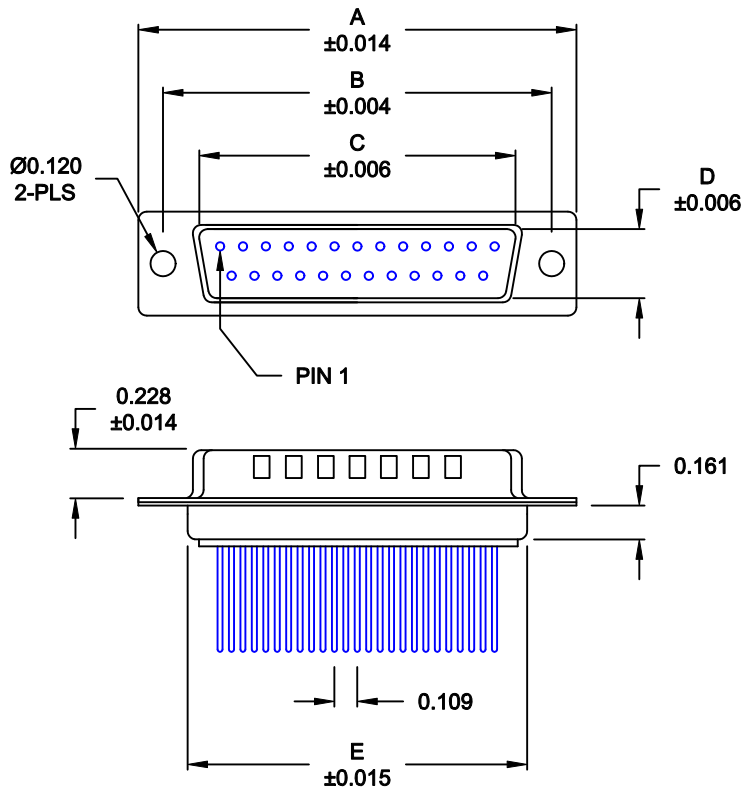

No. OF PINS	DIMENSIONS						
	A	B	C	D	E	F	G
9	1.213	0.984	0.669	0.331	0.760	0.496	0.429
	30.80	24.99	17.00	8.40	19.30	12.60	10.90
15	1.541	1.312	0.996	0.331	1.083	0.496	0.429
	39.15	33.32	25.30	8.40	27.51	12.60	10.90
25	2.088	1.852	1.535	0.331	1.630	0.496	0.429
	53.04	47.04	39.00	8.40	41.40	12.60	10.90
37	2.729	2.500	2.181	0.331	2.276	0.496	0.429
	69.32	63.50	55.40	8.40	57.81	12.60	10.90
50	2.635	2.406	2.079	0.437	2.182	0.598	0.535
	66.93	61.11	52.80	11.10	55.42	15.20	13.60

**172-YYY-142RYY1**

- SERIES \_\_\_\_\_
- POSITIONS \_\_\_\_\_
- 009 \_\_\_\_\_
- 015 \_\_\_\_\_
- 025 \_\_\_\_\_
- 037 \_\_\_\_\_
- 050 \_\_\_\_\_
- GENDER \_\_\_\_\_
- 1 = MALE
- TERMINATION \_\_\_\_\_
- 4 = WIRE WRAP
- SHELL PLATING \_\_\_\_\_
- 2 = TIN (GROUND INDENTS)
- RoHS COMPLIANT \_\_\_\_\_
- HARDWARE OPTIONS \_\_\_\_\_
- 00 = NO HARDWARE
- 01 = .065" CLINCH NUT (BOARD SIDE)
- 02 = .250" CLINCH NUT (BOARD SIDE)
- 03 = .250" CLINCH NUT (MOUNTING SIDE)
- 05 = .237" 4-40 BOARD LOCK
- 91 = .237" 4-40 SPACER/ BOARD LOCK
- PLATING OPTIONS \_\_\_\_\_
- 1 = GOLD FLASH
- 2 = 30MICRO-INCH GOLD

**MATERIAL:**

- SHELL: STEEL, TIN PLATED
- INSULATOR: UL 94V-O RATED, BEIGE PBTP
- PROCESS TEMP.: 260° C
- CONTACT: BRASS

**ELECTRICAL:**

- CURRENT RATING: 5 AMPS
- CONTACT RESISTANCE: 15 mOhms Max.
- INSULATION RESISTANCE: 1,000 MOhms min.
- VOLTAGE: 500VAC FOR 1 MINUTE
- TEMPERATURE: -50° C TO 100° C

**DO NOT SCALE FROM DRAWING**

	THESE DRAWINGS AND SPECIFICATIONS ARE THE PROPERTY OF NorComp AND SHALL NOT BE REPRODUCED, COPIED OR USED AS THE BASIS FOR THE MANUFACTURE OF SALE OF APPARATUS WITHOUT WRITTEN PERMISSION.		DRAWN: PAM JENKINS	DATE: 11-23-05
			CHECKED:	DATE:
<b>NorComp</b>		SCALE: 1:1	SHEET 1 OF 3	REV 11
		DWG NO. 172-YYY-142RYY1		

**RoHS COMPLIANT**

DESCRIPTION: PCB LAYOUT - STANDARD "D" - MALE & FEMALE

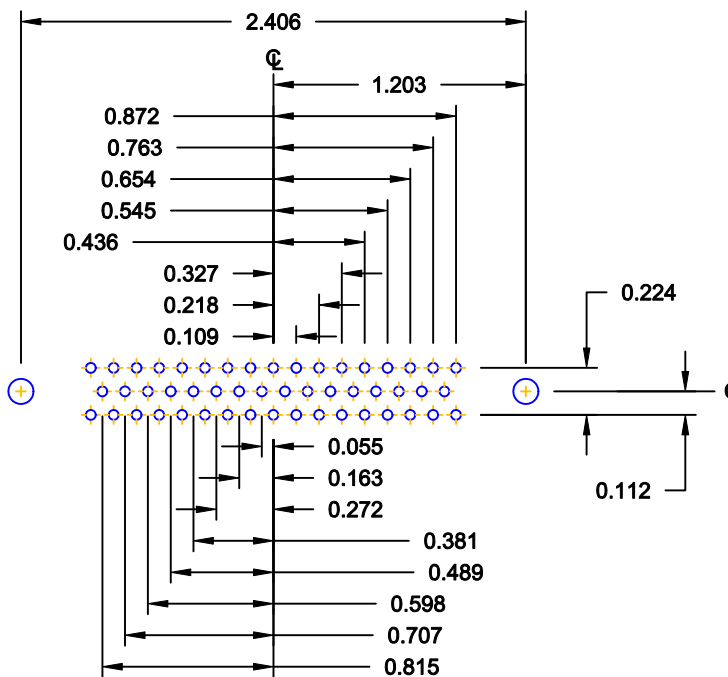
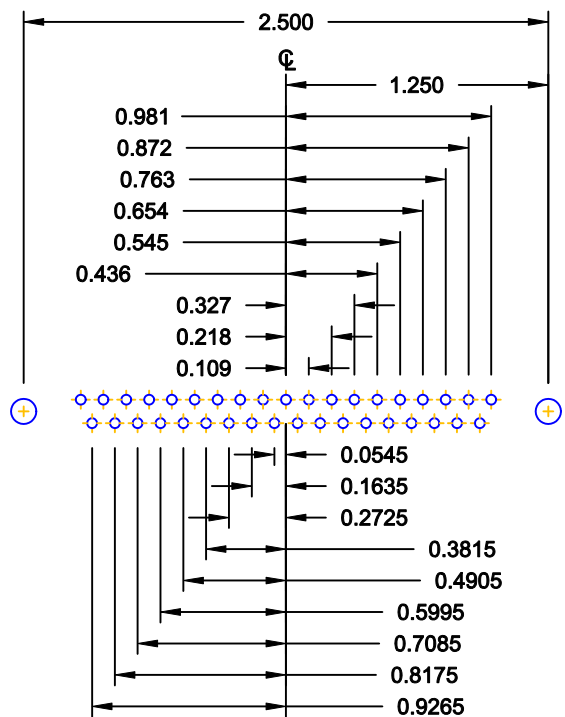
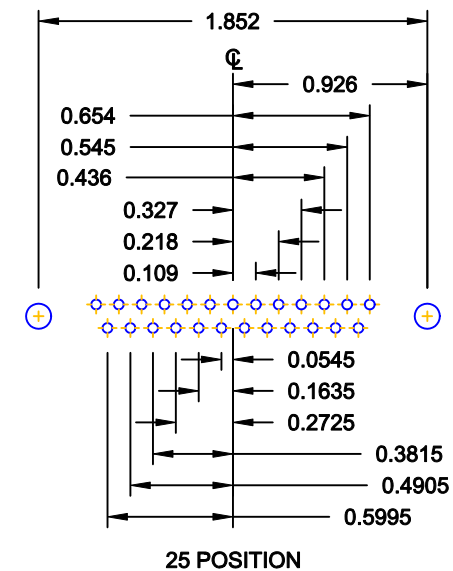
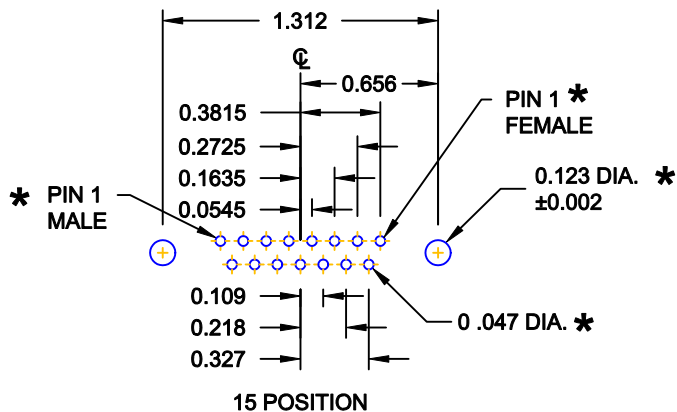
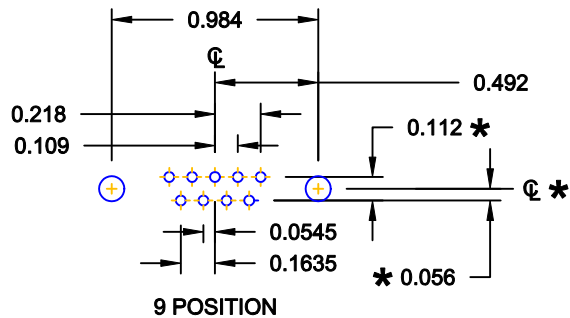

\* TYP. ON ALL SIZES

DO NOT SCALE FROM DRAWING



THESE DRAWINGS AND SPECIFICATIONS ARE THE PROPERTY OF NorComp AND SHALL NOT BE REPRODUCED, COPIED OR USED AS THE BASIS FOR THE MANUFACTURE OF SALE OF APPARATUS WITHOUT WRITTEN PERMISSION.

DRAWN: C. SMITH		DATE: 03-08-06	
CHECKED:		DATE:	
SCALE: FULL	SHEET 2 OF 3	REV 11	
DWG NO. 172-YYY-142RYY1			

NorComp

**ALL CLINCH-NUTS ARE 4-40 INTERNAL THREADS**

01X ..... 0.065" (BOARD SIDE) - CN1

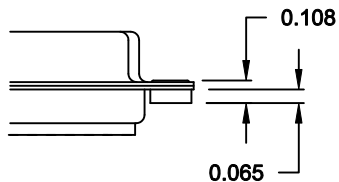

05X ..... 0.237" (BOARD SIDE) - CN10

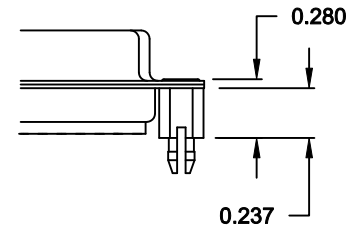

02X ..... 0.250" (BOARD SIDE) - CN2

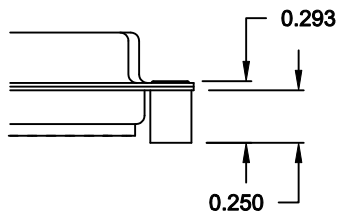

91X ..... 0.237" (BOARD SIDE) - 0.197" MATING SIDE - CN10/SFSO4404

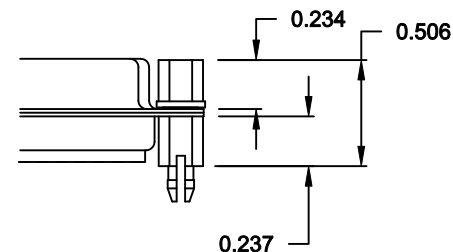

03X..... 0.250" (MATING SIDE) - CN8

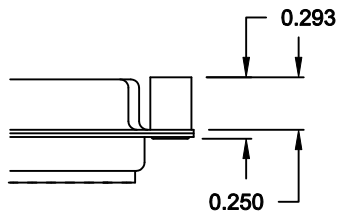

NOTE: 4-40 FEMALE SCREW LOCK IS REMOVABLE

**DO NOT SCALE FROM DRAWING**

**RoHS COMPLIANT**

	THESE DRAWINGS AND SPECIFICATIONS ARE THE PROPERTY OF NorComp AND SHALL NOT BE REPRODUCED, COPIED OR USED AS THE BASIS FOR THE MANUFACTURE OF SALE OF APPARATUS WITHOUT WRITTEN PERMISSION.		DRAWN: <b>WAYNE ROBBINS</b>	DATE: <b>11-28-05</b>
			CHECKED:	DATE:
<h1>NorComp</h1>		SCALE:	SHEET <b>3</b> OF <b>3</b>	REV <b>11</b>
		DWG NO. <b>172-YYY-142RYY1</b>		