

NOTES:

1. MATERIALS OF CONSTRUCTION:

BODY = ZINC DIE CAST, NICKEL PLATED (.000100 MIN. THICK)  
 CONTACT PIN = PHOSPHOR BRONZE (QQ-B-750), GOLD FLASH OVER NICKEL PLATED (.000050 MIN THICK)  
 POST = COPPER, MATTE TIN PLATED OVER NICKEL (.000050 MIN)  
 CONTACT TAILS ARE TIN OVER NICKEL (.000050 THICK)  
 FORK PINS (2) = BRASS (QQ-B-613), TIN PLATED  
 LOCKWASHER = BRASS (QQ-B-613) OR STAINLESS STEEL (ASTM A582), NICKEL PLATED (.000100 MIN THICK)  
 HOUSING = PBT (UL 94 V-0), COLOR BLACK  
 INSULATOR = POLYPROPYLENE (UL 94 HB), COLOR NATURAL  
 HEX NUT = BRASS (ASTM-B16 H02, C36000), NICKEL PLATED (.000100 MIN. THICK)

3. MAX. PANEL THICKNESS = 5mm [.197]

31-5538-10RFX		REVISIONS			
DRAWING NO.	REV	DESCRIPTION	DATE	ECO	APPR
THIRD ANGLE PROJ.	A	RELEASE TO MFG.	3/7/02	43981	CPM
	B	MATTE TIN WAS BRIGHT TIN; CONT TAILS WERE TIN/LEAD	11/8/05	45777	CPM
	C	NOTE 1 ADD STEEL TO LOCKWASHER; FIXED VIEW	6/2/06	46109	CPM

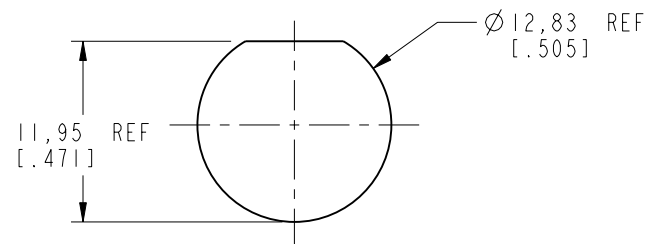
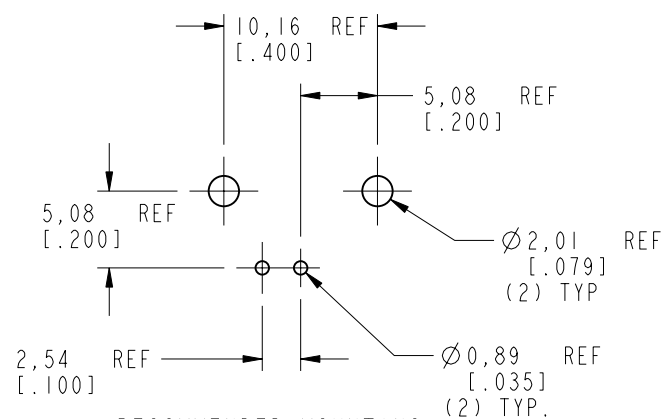
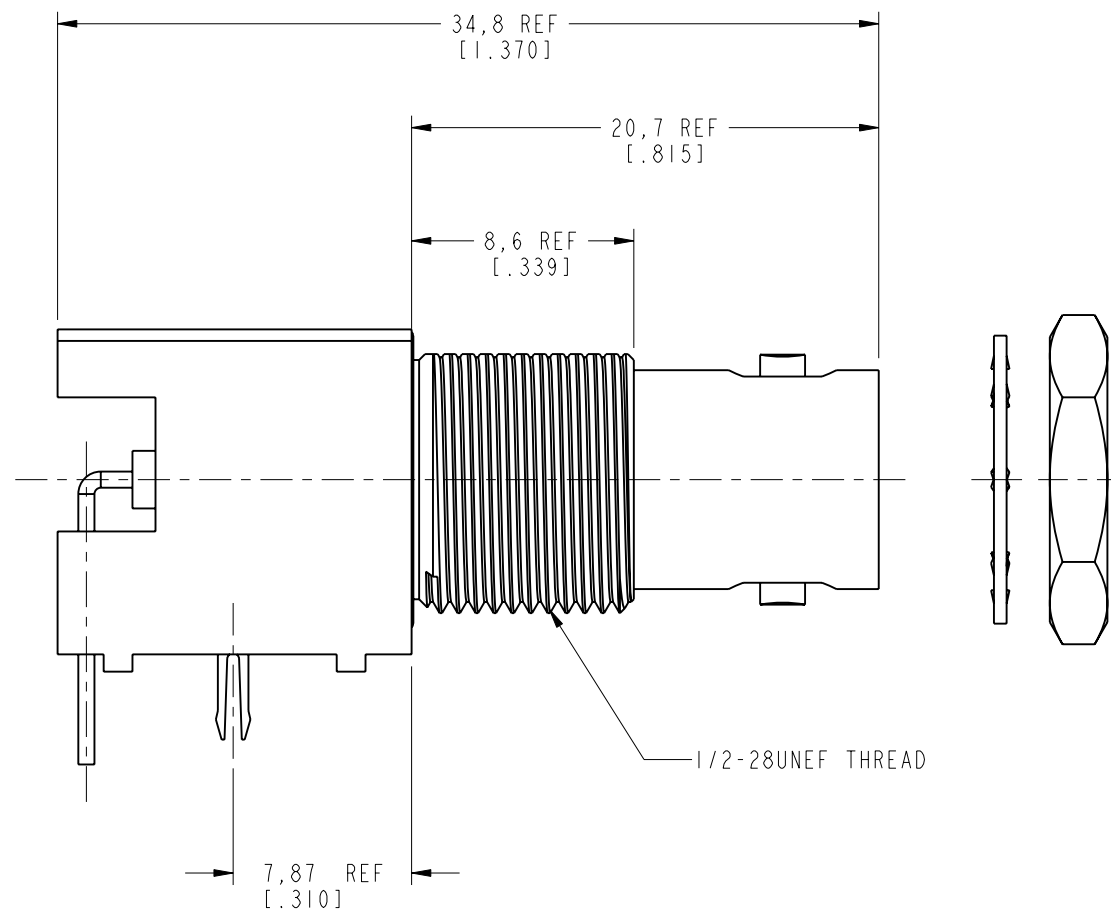
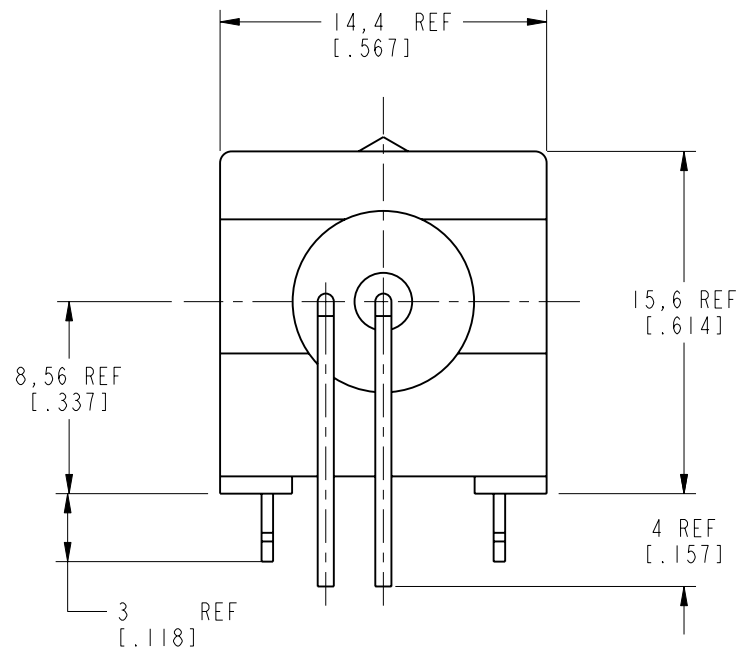

RECOMMENDED MOUNTING HOLE DIMENSIONS SCALE 2.000

RECOMMENDED MOUNTING HOLE DIMENSIONS SCALE 2.000

**CUSTOMER OUTLINE DRAWING**  
 ALL OTHER SHEETS ARE FOR INTERNAL USE ONLY

UNLESS OTHERWISE SPECIFIED, DIMENSIONS ARE IN MM (INCHES) AND TOLERANCES ARE: 0.5 - 6mm ±0.2mm 6 - 30mm ±0.4mm 30 - 120mm ±0.6mm	MATERIAL	DRAWN C. McGRATH	DATE 2/22/02	TITLE BNC R/A PC MOUNT RECEPTACLE JACK		Amphenol Amphenol Corporation Communication and Network Products Division Danbury, CT U.S.A. 06810	
	REFERENCE EAR# 363 GEN# 31-5431-10RFX_ASSY	ENGINEER O. BARTHELMES	DATE 2/22/02				
NOTICE - These drawings, specifications, or other data (1) are, and remain the property of Amphenol Corp. (2) must be returned upon request; and (3) are confidential and not to be disclosed to any person other than those to whom they are given by Amphenol Corp. The furnishing of these drawings, specifications, or other data by Amphenol Corp., or to any other person to anyone for any purpose is not to be regarded by implication or otherwise in any manner licensing, granting rights or permitting such holder or any other person to manufacture, use or sell any product, process or design, patented or otherwise, that may in any way be related to or disclosed by said drawings, specifications, or other data.		APPROVED O. BARTHELMES	DATE 2/27/02	CODE ID 74868	DWG SIZE B	DRAWING NO. 31-5538-10RFX	REV C
						SCALE: 3.0:1	SHEET 2 OF 2