

**NOTES:**

- ① MAT'L: COPPER (STOCK TKN.  $\frac{.031}{.79}$  )  
PLATING: ELECTRO-TIN (.0003 MIN.)
- ② BRAZED SEAM

STUD SIZES: (+.005)

- 02 = .094
- 04 = .119
- 06 = .146
- 08 = .173
- 10 = .198
- 14 = .265
- 56 = .328
- 38 = .390

"UL" LISTING # E32244  
"CSA" LISTING # 18689

ALL DIMENSIONS = INCHES  
MM

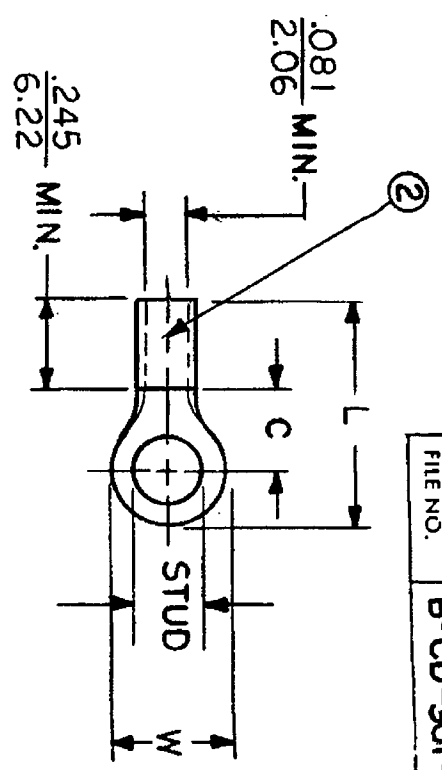

FILE NO.

B-CD-301-01

WIRE SIZE: 16-14 AWG  
1.0-2.5 MM<sup>2</sup>

PART NUMBER	"W" ±.010	"C" MIN.	"L" MAX.	SCALE:	NTS	DATE	TITLE:	DWG. NO.	CUSTOMER DWG.
B-318-	$\frac{.534}{13.56}$	$\frac{.554}{14.07}$	$\frac{1.115}{28.32}$	DRWN. BY: JJ	112884	11.30.84	RING TONGUE TERMINAL	A	
B-323-	$\frac{.250}{6.35}$	$\frac{.209}{5.31}$	$\frac{.639}{16.23}$	CHKD. BY: GZ			VERSAKRIMP 300-SERIES		
B-325-	$\frac{.467}{11.86}$	$\frac{.388}{9.86}$	$\frac{.916}{23.27}$	APPRD. BY:					
B-337-	$\frac{.312}{7.92}$	$\frac{.285}{7.24}$	$\frac{.730}{18.54}$						
B-339-	$\frac{.342}{8.69}$	$\frac{.310}{7.87}$	$\frac{.775}{19.69}$						



DWG. NO. A CUSTOMER DWG.