

LOC	DIST	REVISIONS			
P	LTR	DESCRIPTION	DATE	OWN	APVD
AF	50				
Y		REV PER 063A-0634-01	12NOV01	JR	DD

- 1 CONTINUOUS STRIP ON REELS.
 - 2 TERMINAL TO ACCEPT A 0.51 [.020] X 3.18 [.125] TIN PLATED TAB.
 - 3 THIS PART TO BE USED WITH HOUSING PART NUMBERS; 480553 AND 480556.
- △ 0.000381 [.000015] MIN PRE-TIN PLATE.
 - △ 0.002032 [.000080] MIN POST-TIN PLATE.
 - △ PREPRODUCTION - F.A.S.R. REQUIRED.

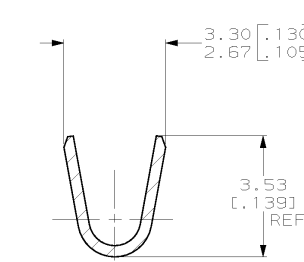
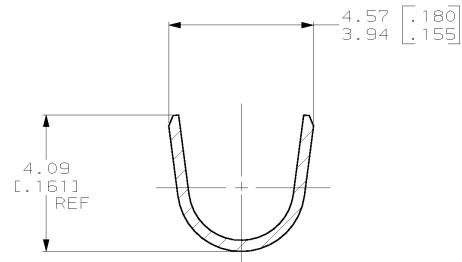
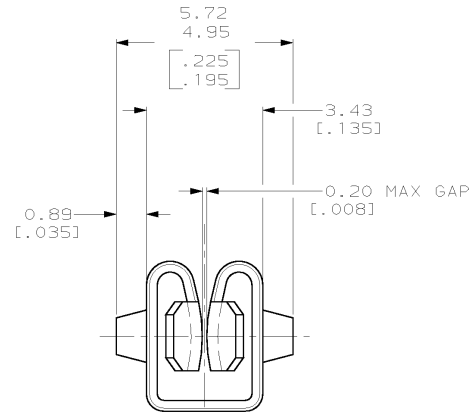
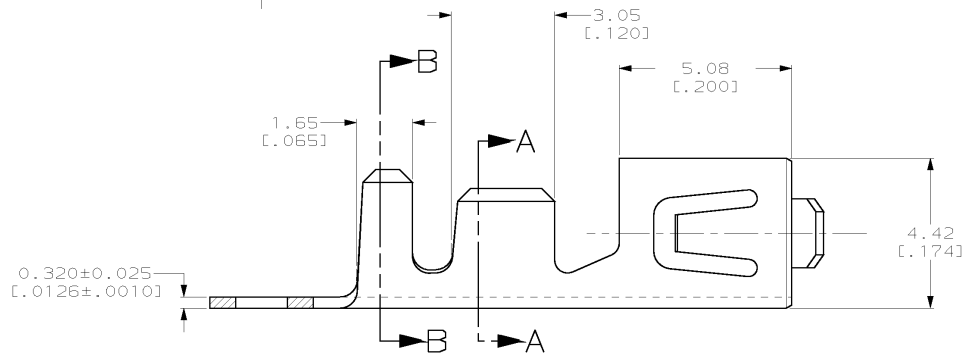
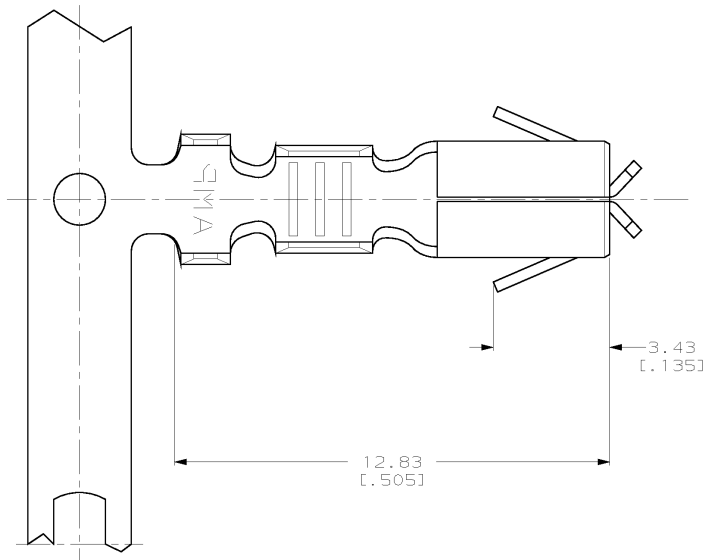

	△ 5	H06 BRASS	2.16-3.18 [.085-.125]	#20-#14 AWG	△ 6 61603-5
OBSOLETE	NONE	SPRING COPPER	2.16-3.18 [.085-.125]	#20-#14 AWG	61603-4
OBSOLETE	△ 4	SPRING COPPER	2.16-3.18 [.085-.125]	#20-#14 AWG	61603-3
OBSOLETE	NONE	H06 BRASS	2.16-3.18 [.085-.125]	#20-#14 AWG	61603-2
	△ 4	H06 BRASS	2.16-3.18 [.085-.125]	#20-#14 AWG	61603-1
FINISH	MATERIAL	INSULATION RANGE	WIRE RANGE	PART NUMBER	

THIS DRAWING IS A CONTROLLED DOCUMENT.

DRN MICHAEL S. FEHER 26AUG2000	AMP Incorporated Harrisburg, PA 17105-3608
CHK DONALD DECKER 25AUG2000	
APVD DONALD DECKER 25AUG2000	
NAME DONALD DECKER	
PRODUCT SPEC	
APPLICATION SPEC	
SIZE	CASE CODE (DRAWING NO)
WEIGHT	A200779 61603
CUSTOMER DRAWING	SCALE 10:1 SHEET 1 OF 1 REV Y