

## DESCRIPTION

Demonstration Circuit 756 is a 2.7V to 9V battery gas gauge and coulomb counter. The LTC4150 measures battery depletion and charging by monitoring current through a sense resistor. It detects the direction of the current to indicate with its polarity pin the charge or discharge of a battery. A voltage-to-frequency converter transforms the current sense voltage into a series of output pulses at the interrupt pin. These pulses correspond to a fixed quantity of charge flowing into or out of the battery.

A shift register on the DC756 is used to input the LTC4150 polarity and interrupt output as well as the presence of a battery or charger. The QuickEval DC590 uses a serial peripheral interface to read the shift register. The data is interpreted and displayed

on the DC756 software interface. QuickEval also sends a clear command when an interrupt is read.

One jumper on the DC756 sets the interrupt clear for a self clear where the interrupt is used to clear the LTC4150 or an external clear. Another jumper sets the DC756 to normal operation or a low-current shut-down mode. A bi-colored LED indicates the charge or discharge of a battery.

**Design files for this circuit board are available. Call the LTC factory.**

LTC and QuickEval are trademarks of Linear Technology Corporation

**Table 1. Typical Performance Summary**

PARAMETER	CONDITION	VALUE
Battery Voltage	Min./Max. Voltage range	2.7 V to 9V
Charger Voltage	Min./Max. Voltage range	2.7 V to 9V
Maximum Sense Current	Default Sense Resistor 0.01 $\Omega$ , 1/8 W Sense Resistor	3.5A
Gvf	Nominal Voltage to Frequency Gain	32.55Hz/V

## QUICK START PROCEDURE

Demonstration circuit 756 is easy to set up to evaluate the performance of the LTC4150. Refer to Figure 1 for proper measurement equipment setup and follow the procedure below:

- 1) Connect the battery to  $V_{BAT}$ .
- 2) Connect a load or charger to  $V_{L/CHRG}$ .
- 3) Connect the 14-pin ribbon cable to J1 and to the DC590. Connect the DC590 to a PC and open the QuickEval software.

- 4) Place shunts on the jumpers in the following positions:

**JP1**      RUN

**JP2**      EXT CLR

**NOTE:** Make sure that the battery or charger voltage does not exceed 9V.

# QUICK START GUIDE FOR DEMONSTRATION CIRCUIT 756 COULOMB COUNTER/BATTERY GAS GAUGE

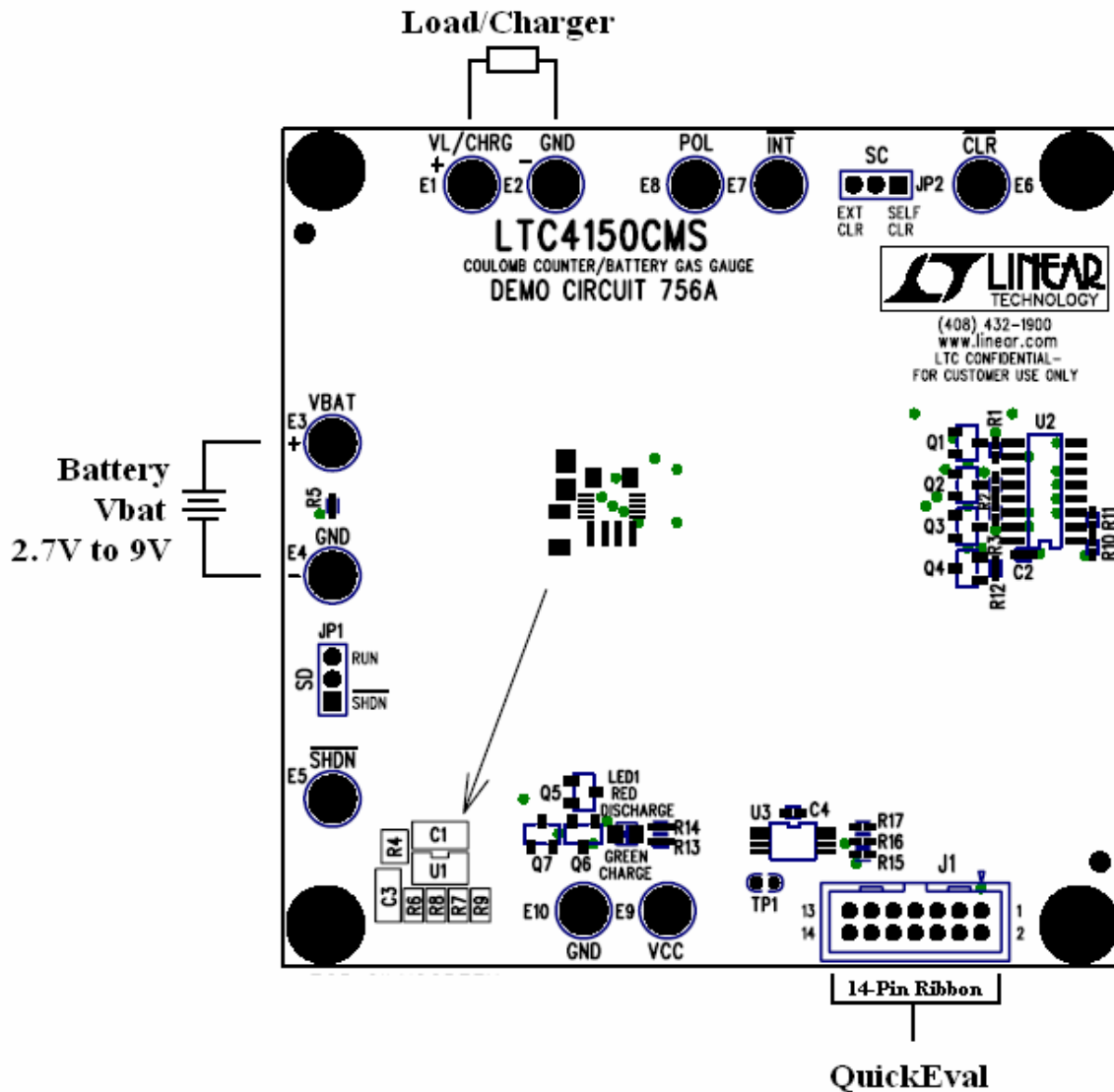

Figure 1. Proper Measurement Equipment Setup

## OPERATION

### BATTERY, LOAD, CHARGER

A battery is connected to  $V_{BAT}$  on the DC756 and the load or battery charger is connected to  $V_L/CHRG$ . N-Channel MOSFETs are used to interface the LTC4150 with the shift register. The outputs of the LTC4150 drive the gates of the MOSFETs pulled up to the microprocessor supply to the shift register. This design on the DC756 allows for a battery and charger voltage range from 2.7V to 9V. Example batteries the LTC4150 is intended for are 1-cell or 2-cell Li-Ion and 3-cell to 6-cell NiCd or NiMH.

### RSENSE

RSENSE is selected such that:

$$I_{MAX} = 50\text{mV} / R_{SENSE}$$

On the DC756, up to 3.5A can pass through the 0.01 Ohm, 1/8W RSENSE. The equivalent value resistor in the next larger package is rated for 1/4W and can pass through the calculated maximum current of 5A.

### INTERRUPT AND CLEAR

Every time a packet of Coulombs passes through the sense resistor, the LTC4150 pulls low on its /INT pin and remains low until the /CLR pin is pulled low. On the DC756, the /INT pin can be tied to the /CLR pin so the LTC4150 can self-clear the interrupt with JP2 or separated for microprocessor clear.

### POLARITY AND LED INDICATOR

The LTC4150 monitors the current polarity across the sense resistor and indicates the direction with its POL

pin. When POL is high, current is flowing into the battery and when POL is low, current is flowing out of the battery. On the DC756, POL is also used to drive the bi-colored LED and bit one of the shift register. The LED turns red to indicate the battery is discharging, while a green light indicates the battery is charging.

### SHUTDOWN

Shutdown sets the LTC4150 into a low current shutdown mode and disables the LED. Set JP1 to Run for normal operation or to /SHDN to shutdown.

### VOLTAGE SPECIFIC APPLICATIONS

Typically the LTC4150 is directly interfaced with a microprocessor. The battery and charger are a known set voltage. In the final application, if the battery/charger supply voltage is greater than the microprocessor's supply, then the LTC4150 input and output pins can be pulled up to the microprocessor's supply voltage. (See Figure 2)

If the battery/charger voltage is less than the microprocessor's supply, the LTC4150 output pins may be pulled up to the microprocessor supply. But a voltage divider is implemented on the input pins to insure the voltage does not exceed  $V_{DD}$ . Refer to Figure 3 and select the resistor values according to the following equations:

$$V_{DD} \cdot V_{CC} \cdot R_1 / (R_1 + R_2 + R_L)$$

$$V_{DD} \cdot V_{CC} \cdot R_3 / (R_3 + R_4)$$

# QUICK START GUIDE FOR DEMONSTRATION CIRCUIT 756 COULOMB COUNTER/BATTERY GAS GAUGE

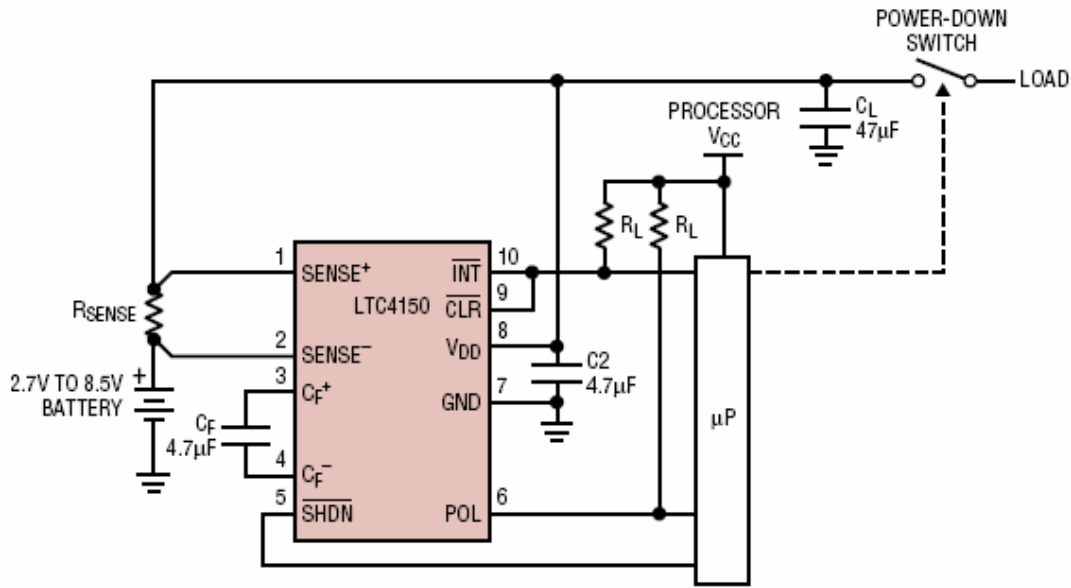

Figure 2. Application with /INT Direct Drive of /CLR and Separate Microprocessor Supply  $V_{DD} \geq V_{CC}$

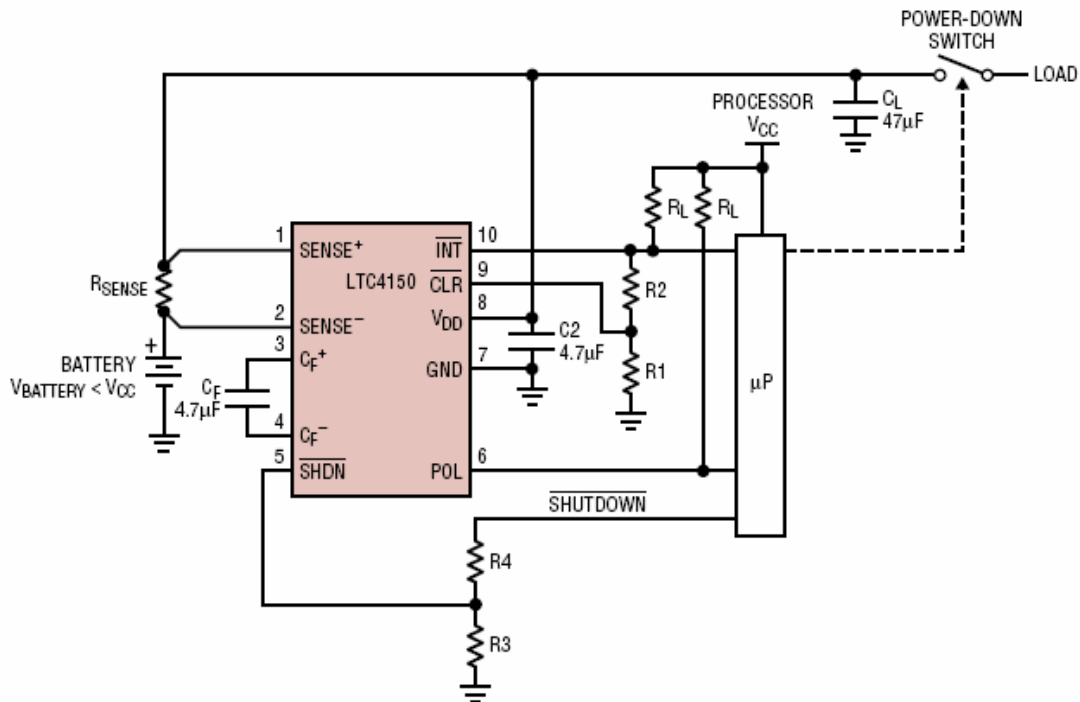

FIGURE 3. Application with /INT Driving /CLR and Separate Microprocessor Supply  $V_{DD} < V_{CC}$

### QUICKEVAL

DC756 is a part of the QuickEval system, which allows for quick evaluation of the LTC4150 with a software interface. DC756 connects via 14-pin ribbon cable to a DC590, USB controller board. The DC590 is connected to a PC through USB. The QuickEval software reads DC756's board ID and opens the software interface shown in Figure 4.

#### 1) Start Counter

The Start Counter check box starts and stops the software timer. When the box is checked, the timer is started and the time is recorded on the "Start Time" label. A read out from the shift register is executed approximately every 50ms. If there is a change in the data from the last read, the interface will be updated and the change is logged on the Data Change Log. When an interrupt is read, a clear bit command is sent.

Unchecking the Start Counter check box stops the timer to halt any data readout and displays the stop time.

#### 2) Board Status

When the software timer is started, the board status is updated. The display will show if either a battery or charger is present. If one is present, the battery charge or discharge is then indicated. When an interrupt line is low, the Interrupt display is shown as True. The clear bit sends a clear bit command to the Clear pin of the LTC4150. A clear bit is sent out to the LTC4150 if the timer is on and an interrupt is read. Clicking Clear Bit manually sends a clear bit.

#### 3) Coulomb Counter

The Coulomb Count display is updated every time an interrupt occurs. When the battery is charging, the

interrupt count increments, while discharging decrements the count. The Max Count shows the highest count and the Min Count is the lowest. Total Up Count counts up every time the battery is charging and total Down Count counts down every time the battery is discharging. Reset Count resets the count display. These counts can also be displayed in Coulombs and milliAmpere-hours (mAh). The unit conversions are as follows:

$$1 \text{ Count} = 1 \text{ Interrupt}$$

$$\# \text{ of Coulombs} = \# \text{ of Interrupts} / (Gvf \cdot R_{SENSE})$$

$$\# \text{ of mAh} = \# \text{ of Interrupts} / (Gvf \cdot R_{SENSE} \cdot 3600)$$

#### 4) Battery Gas Gauge

The battery charge information is displayed here in mAh. Charge remaining increases when a charge and interrupt occurs and decreases from a discharge and interrupt. The amount the charge increments and decrements in the battery depends on the Charge and Discharge Efficiencies entered in the Set Up section.

$$1 \text{ Chrg} = (\text{Charge Eff} / 100) \cdot 1 \text{ Int} / (Gvf \cdot R_{SENSE})$$

$$1 \text{ DsChrg} = (100/\text{DsChrg Eff}) \cdot 1 \text{ Int} / (Gvf \cdot R_{SENSE})$$

The gas gauge display is the charge remaining divided by the maximum charge for the battery. The Max. Charge is entered in the Set Up section.

#### 5) Battery Setup

Enter in the Charge Efficiency and Discharge Efficiency. These efficiencies are calculated into the battery charge in the Battery Gas Gauge section. Enter the Maximum Charge in mAh of the battery connected to the DC756. Enter the value of  $R_{SENSE}$  if the resistor on the board is changed from the original  $0.01\Omega$ .

### 6) Data Change Log

When the software timer is on, any change in the data read will be logged here along with the time of when the data changed.

### 7) Quick Calculations

Quick calculations are performed by the software based off the time interval between the latest two interrupts. The time clocked in for each interrupt is the time shown on the Windows desktop. These calculations will have a  $\pm 500\text{ms}$  tolerance. In an actual ap-

plication, the timing is based off of the microprocessor clock. In the software display, the Time Interval is the time between the latest two interrupts, Frequency is the frequency of the interrupts,  $V_{\text{SENSE}}$  is the voltage across the sense resistor, and  $I_{\text{bat}}$  is the current through the sense resistor. The equations are as follows:

$$\text{Timer Interval} = \text{Time of Int 1} - \text{Timer of Int 2}$$

$$\text{Frequency} = 1 / \text{Time Interval}$$

$$V_{\text{SENSE}} = 1 / (\text{Gvf} \cdot \text{Time Interval})$$

$$I_{\text{bat}} = 1 / (\text{Gvf} \cdot R_{\text{SENSE}} \cdot \text{TimeDifference})$$

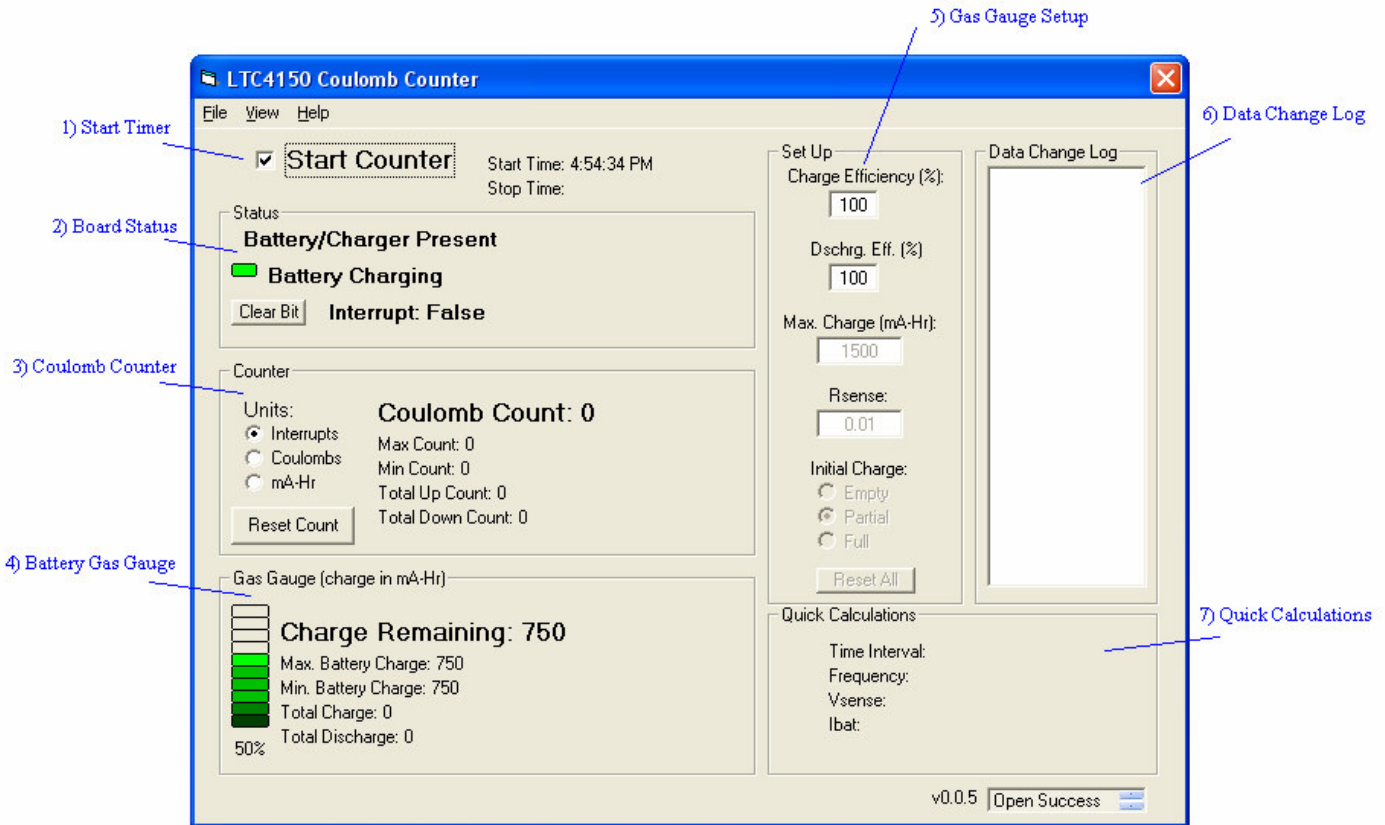

**Figure 4. DC756, LTC4150 QuickEval Software Interface**

# QUICK START GUIDE FOR DEMONSTRATION CIRCUIT 756 COULOMB COUNTER/BATTERY GAS GAUGE

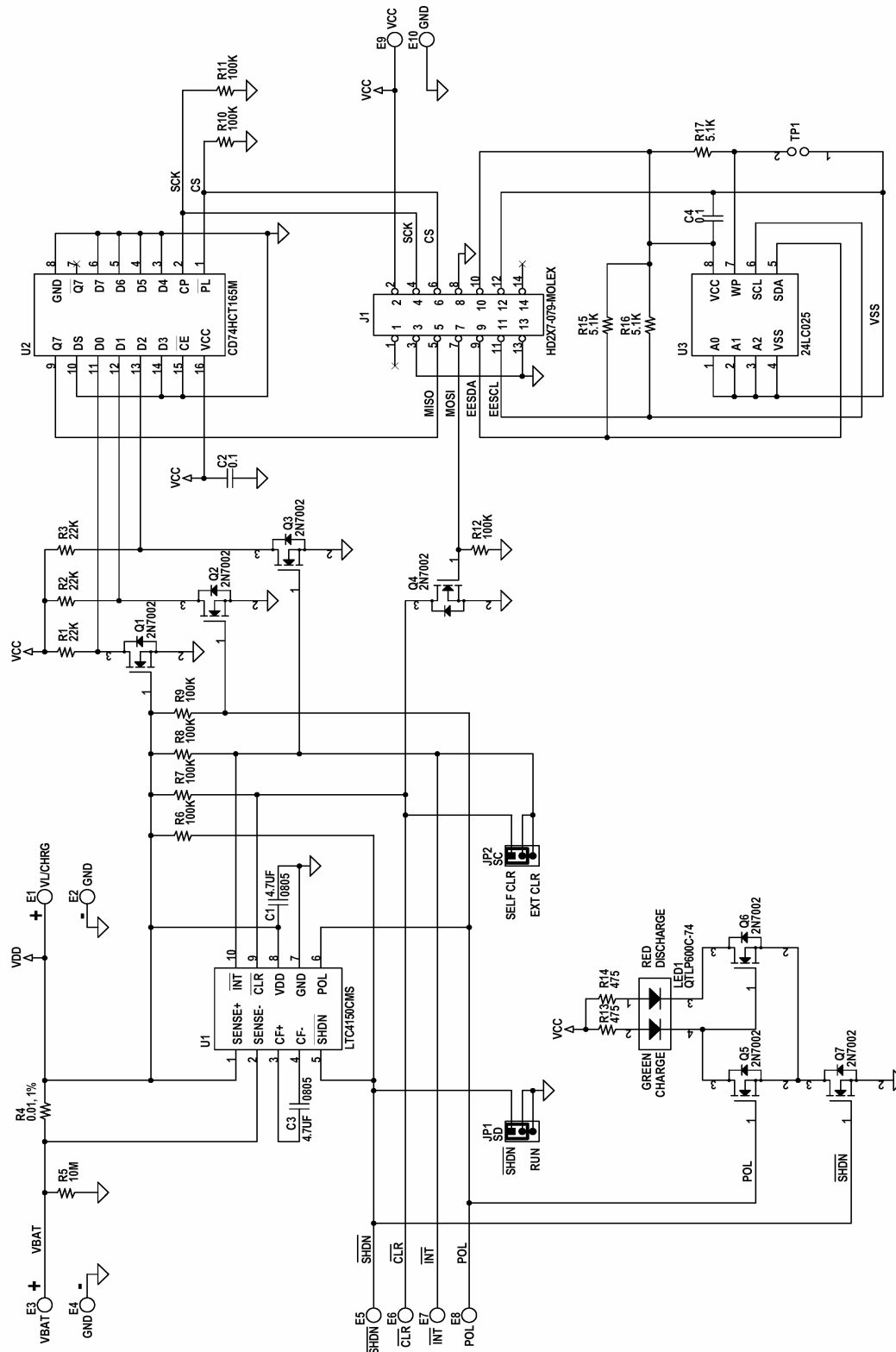

<b>CONTRACT NO.</b>		1630 McCarthy Blvd. Milpitas, CA 95035 Phone: (408)432-1900 Fax: (408)434-0507 LTC Confidential For Customer Use Only	
<b>APPROVALS</b>		<b>LINEAR TECHNOLOGY</b>	
DRAWN: KMT		TITLE: SCHEMATIC	
CHECKED:		COULOMB COUNTER/BATTERY GAS GAUGE	
APPROVED:		REV A	
ENGINEER: DJLJN RL		SIZE A	
DESIGNER:		DWG NO. DC756A-1 * LTC4150CMS	
		DATE: Monday, June 21, 2004	
		SHEET 1 OF 1	

**CUSTOMER NOTICE**  
LINEAR TECHNOLOGY HAS MADE A BEST EFFORT TO DESIGN A CIRCUIT THAT MEETS CUSTOMER-SUPPLIED SPECIFICATIONS; HOWEVER, IT REMAINS THE CUSTOMER'S RESPONSIBILITY TO VERIFY PROPER AND RELIABLE OPERATION IN THE ACTUAL APPLICATION. COMPONENT SUBSTITUTION AND PRINTED CIRCUIT BOARD LAYOUT MAY SIGNIFICANTLY AFFECT CIRCUIT PERFORMANCE OR RELIABILITY. CONTACT LINEAR TECHNOLOGY APPLICATIONS ENGINEERING FOR ASSISTANCE.  
THIS CIRCUIT IS PROPRIETARY TO LINEAR TECHNOLOGY AND SUPPLIED FOR USE WITH LINEAR TECHNOLOGY PARTS.

**NOTES: UNLESS OTHERWISE SPECIFIED**

- ALL RESISTORS ARE IN OHMS, 0402.
- ALL CAPACITORS ARE IN MICROFARADS, 16V, 0402.
- INSTALL SHUNT ON JP1-JP2 PIN 1 AND 2.