

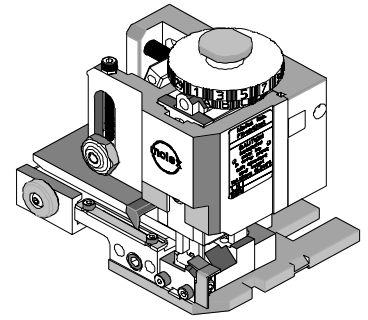

# FineAdjust Applicator Specification Sheet Part No. 63865-6000



## FEATURES

- Quick punch removal with the push of a button for fast and easy tooling change
- Applicator designed to industry standard mounting and shut height 135.80mm (5.346")
- Quick set-up time; plus the crimp height, track and feed adjustments can be set without removing the applicator from the press
- Fine adjustment allows users to achieve target with little effort by adjusting in increments of 0.15mm (.0006") for conductor crimp height and .063mm (.0025") for insulation height
- Independent adjustment rings allow users to quickly adjust the conductor or insulation crimp height without affecting each other
- Directly adapts to most automatic wire processing machines

## SCOPE

Terminal Series No.		Wire Size		Insulation Diameter		Strip Length	
		AWG	mm <sup>2</sup>	mm	In.	mm	In.
19417-0011	Male (Tin)	14-16	2.00-1.27	2.87-3.53	.113-.139	4.20-5.00	.165-.197
19417-0025	Male (Gold)	14-16	2.00-1.27	2.87-3.53	.113-.139	4.20-5.00	.165-.197
19417-0027	Male (Tin)	14-16 Long	2.00-1.27	2.87-3.53	.113-.139	4.20-5.00	.165-.197
19417-0029	Male (Gold)	14-16 Long	2.00-1.27	2.87-3.53	.113-.139	4.20-5.00	.165-.197
19420-0001	Female (Tin)	14-16	2.00-1.27	2.87-3.53	.113-.139	4.20-5.00	.165-.197
19420-0003	Female (Gold)	14-16	2.00-1.27	2.87-3.53	.113-.139	4.20-5.00	.165-.197

## DEFINITION OF TERMS

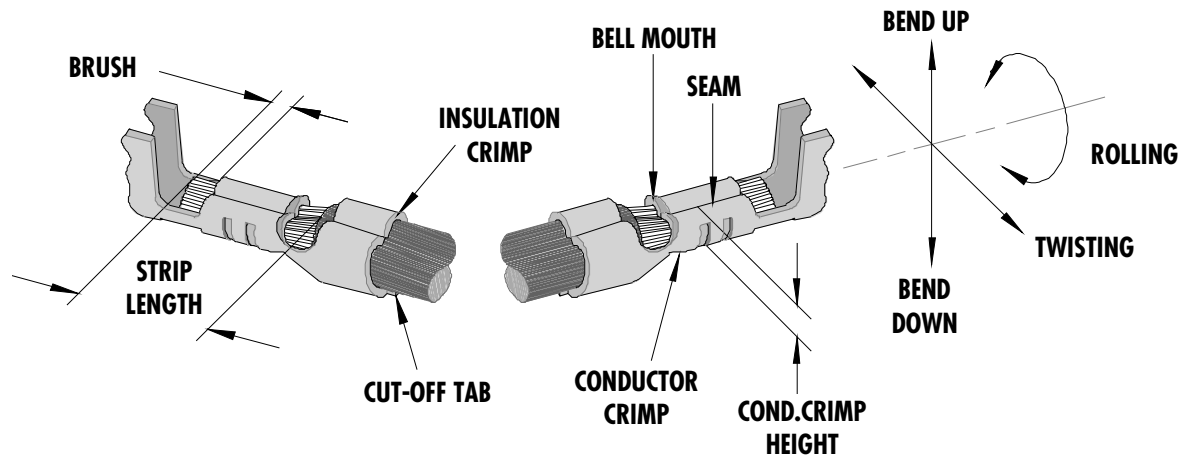

The above terminal drawing is a generic terminal representation. It is not an image of a terminal listed in the scope.

**CRIMP SPECIFICATION**

Terminal Series No.	Bell mouth		Cut-off Tab Max.		Conductor Brush	
	mm	In.	mm	In.	mm	In.
19417-0011	0.25-1.25	.010-.049	0.50	.020	0.15-0.65	.006-.026
19417-0025	0.25-1.25	.010-.049	0.50	.020	0.15-0.65	.006-.026
19417-0027	0.25-1.25	.010-.049	0.50	.020	0.15-0.65	.006-.026
19417-0029	0.25-1.25	.010-.049	0.50	.020	0.15-0.65	.006-.026
19420-0001	0.25-1.25	.010-.049	0.50	.020	0.15-0.65	.006-.026
19420-0003	0.25-1.25	.010-.049	0.50	.020	0.15-0.65	.006-.026

Terminal Series No.	Bend up	Bend down	Twist	Roll	Punch Width mm (Ref)				Seam
	Degree		Degree		Conductor		Insulation		
					mm	In	mm	In	
19417-0011	5	5	4	8	2.50	.098	4.30	.169	Seam shall not be open and no wire allowed out of the crimping area
19417-0025	5	5	4	8	2.50	.098	4.30	.169	
19417-0027	5	5	4	8	2.50	.098	4.30	.169	
19417-0029	5	5	4	8	2.50	.098	4.30	.169	
19420-0001	5	5	4	8	2.50	.098	4.30	.169	
19420-0003	5	5	4	8	2.50	.098	4.30	.169	

After crimping, the conductor profile should measure the following.

Terminal Series No.	Wire Size		Conductor Crimp Height		Insulation Crimp Height		Pull Force Min.	
	AWG	mm <sup>2</sup>	mm	In.	Mm (Ref)	In. (Ref)	N	Lb.
19417-0011	14	2.00	1.65-1.75	.065-.069	3.40 max.	.130 max.	222.6	50.00
19417-0011	16	1.27	1.60-1.70	.063-.067	3.40 max.	.130 max.	133.5	30.00
19417-0025	14	2.00	1.65-1.75	.065-.069	3.40 max.	.130 max.	222.6	50.00
19417-0025	16	1.27	1.60-1.70	.063-.067	3.40 max.	.130 max.	133.5	30.00
19417-0027	14	2.00	1.65-1.75	.065-.069	3.40 max.	.130 max.	222.6	50.00
19417-0027	16	1.27	1.60-1.70	.063-.067	3.40 max.	.130 max.	133.5	30.00
19417-0029	14	2.00	1.65-1.75	.065-.069	3.40 max.	.130 max.	222.6	50.00
19417-0029	16	1.27	1.60-1.70	.063-.067	3.40 max.	.130 max.	133.5	30.00
19420-0001	14	2.00	1.45-1.55	.057-.061	3.40 max.	.130 max.	222.6	50.00
19420-0001	16	1.27	1.40-1.50	.055-.059	3.40 max.	.130 max.	133.5	30.00
19420-0003	14	2.00	1.45-1.55	.057-.061	3.40 max.	.130 max.	222.6	50.00
19420-0003	16	1.27	1.40-1.50	.055-.059	3.40 max.	.130 max.	133.5	30.00

Pull Force should be measured with no influence from the insulation crimp.

The above specifications are guidelines to an optimum crimp.

**PARTS LIST**

Item	Order No	Engineering No.	Description	Quantity
	<b>63865-6000</b>	<b>63865-6000</b>	<b>FineAdjust Applicator (Fig. 1)</b>	<b>REF</b>
1	63444-2524	63444-2524	Conductor Punch	1 Y
2	63455-2501	63455-2501	Conductor Anvil	1 Y
3	63460-4301	63460-4301	Insulation Punch	1 Y
4	63445-4322	63445-4322	Insulation Anvil	1 Y
5	63443-0035	63443-0035	Cut-Off Plunger	1 Y
6	63443-0036	63443-0036	Front Plunger Retainer	1 Y
7	11-18-4080	60707-5	Wire Stop	1
8	11-18-4083	60707-8	Front Cover	1
9	11-17-0022	1739-21	Hold Down Spring	1
10	11-24-1149	4996-37	Shank	1
11	63443-0009	63443-0009	Scrape Chute	1
12	63443-0021	63443-0021	Lower Tooling Key	1
13	63443-2508	63443-2508	Anvil Mount	1
14	63443-3160	63443-3160	Front Plunger Striker	1
15	63443-6013	63443-6013	Rear Cover	1
16	63700-0539	63700-0539	Cut-off Plunger Spring	1
17	63801-3100	63801-3100	Wide Track Fine Adjust Applicator Frame	1
18	N/A	N/A	M3 by 6Lg. SHCS	2**
19	N/A	N/A	M4 by 6Lg. SHCS	1**
20	N/A	N/A	M4 by 12Lg. BHCS	2**
21	N/A	N/A	M4 by 50Lg. SHCS	2**
22	N/A	N/A	M5 by 12Lg SHCS	1**
23	N/A	N/A	3MM by 6Lg. Roll Pin	1**
24	N/A	N/A	#5-40 Hex Nut	1**
25	N/A	N/A	#5-40 by 3/4 LG. SHCS	1**
26	N/A	N/A	#10-32 by 1/4"Lg. BHCS	1**
	<b>63865-6070</b>	<b>63865-6070</b>	<b>Tool Kit (All Y Items)</b>	<b>REF</b>

\*\* The following purchased parts are available from an Industrial supply company such as MSC (1-800-645-7270).

# Assembly Drawing

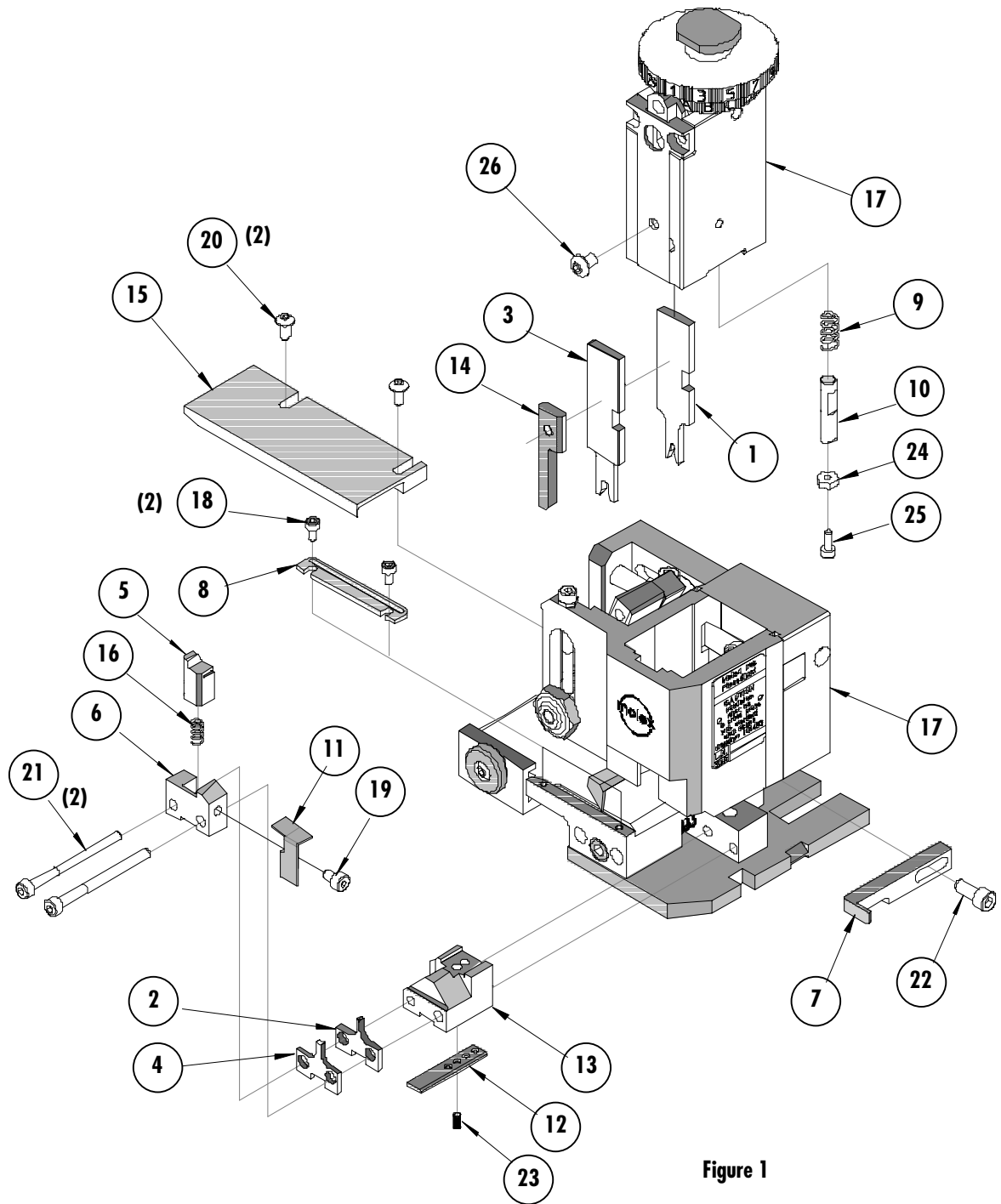

Figure 1

## NOTES

1. Molex recommends an extra perishable tooling kit be maintained at your facility.
2. Verify tooling alignment by manually cycling the press and Applicator before crimping under power. Check that all screws are tight.
3. Slugs, Terminals, Dirt and Oil should be kept clear of work area.
4. Wear safety glasses at all times.
5. For recommended maintenance refer to the FineAdjust Manual.

**CAUTION:** This applicator should only be used in a press with a shut height of 135.8 mm (5.346"). Tooling damage could result at a lower setting.

**CAUTION:** To prevent injury never operate this Applicator without the guards supplied with the press or wire-processing machine in place. Reference the press or wire processing manufacturer's instruction manual.

**CAUTION:** Molex crimp specifications are valid only when used with Molex terminals, applicators and tooling.

### **Molex Application Tooling Group**

1150 E. Diehl Road  
Naperville, IL 60563  
Tel: (630) 969-4550  
Fax: (630) 505-0049

Visit our Web site at <http://www.molex.com>