

REV.	DESCRIPTION	DATE	APPROVED
F	Updated Material.	10/28/08	T. Y.
G	Added Ordering Information.	06/06/11	T. Y.
H	Removed Part Numbers from Part Offering List.	05/06/15	J. C.
J	Updated Material Description.	10/09/15	J. C.
K	Engineering Update w/o Changes.	10/22/15	J. C.

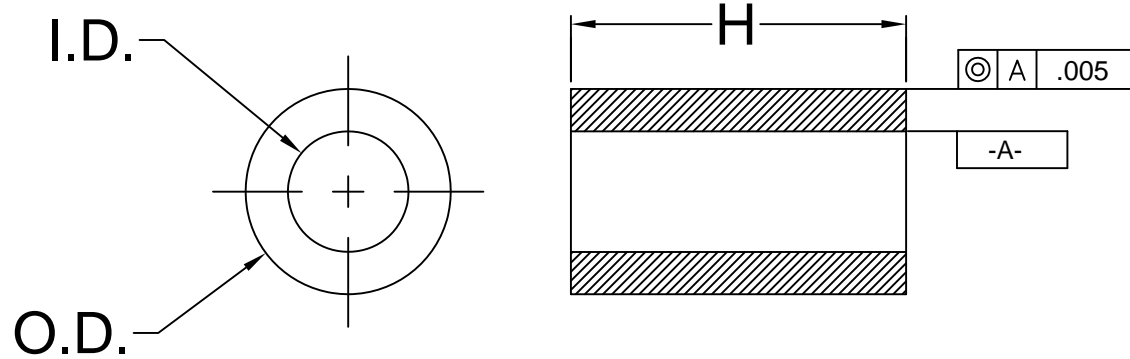

SERIES	"H" DIMENSION	I.D.	O.D.
901	.030-1.250 (.76-31.8)	.028 (.71)	.085 (2.2)
902	.030-1.250 (.76-31.8)	.032 (.81)	.125 (3.2)
903	.030-1.250 (.76-31.8)	.047 (1.2)	.156 (4.0)
904	.030-1.250 (.76-31.8)	.063 (1.6)	.187 (4.7)
905	.030-1.250 (.76-31.8)	.147 (3.7)	.250 (6.4)
906	.030-1.250 (.76-31.8)	.085 (2.2)	.148 (3.8)
907	.030-1.250 (.76-31.8)	.105 (2.7)	.167 (4.2)
908	.030-1.250 (.76-31.8)	.125 (3.2)	.187 (4.7)
911	.030-1.250 (.76-31.8)	.125 (3.2)	.250 (6.4)
912	.030-1.250 (.76-31.8)	.171 (4.3)	.250 (6.4)
913	.030-1.250 (.76-31.8)	.091 (2.3)	.187 (4.7)
937	.030-1.250 (.76-31.8)	.090 (2.3)	.125 (3.2)
938	.030-1.250 (.76-31.8)	.032 (.81)	.085 (2.2)
939	.030-1.250 (.76-31.8)	.047 (1.2)	.125 (3.2)
940	.030-1.250 (.76-31.8)	.063 (1.6)	.156 (4.0)

ORDERING INFORMATION:

9XX-XXX

SERIES LENGTH
 INCHES, MULTIPLES OF .005"
 .030" = 030
 .100" = 100
 1.250" = 1.250



WHOLE MILLIMETERS
 2mm = 2MM
 5mm = 5MM

3. TOLERANCE "H" DIMENSION:

0.030 - 0.500 (1.0 - 12.7mm)±0.005(0.1mm)
 0.505 - 0.750 (12.8 - 19.1mm)±0.008(0.2mm)
 0.755 - 1.250 (19.2 - 31.8mm)±0.015(0.4mm)

2. MATERIAL: NYLON 6, ULTRAMID 8270 HS, NATURAL. BIVAR MATERIAL CODE 01-NL-WE.
 ALLIED CHEMICAL POLYAMID NYLON 6 WITH CLARIANT CNY02655 WHITE NYLON CONCENTRATE.

1. GENERAL SPECIFICATIONS: BIVAR EXTRUDED PRODUCT SPECIFICATION BV00-E103.

STANDARD TOLERANCE (UNLESS OTHERWISE SPECIFIED)		 4 THOMAS, IRVINE, CA. 92618 TEL: (949) 951-8808 FAX: (949) 951-3974	
DECIMALS	ANGULAR		
.X ±.1	X° ±1°		TITLE: NYLON TUBE SPACERS
.XX ±.01			PART NO: 9XX-XXX
.XXX ±.005			REVISION: K
DESIGNED: Michael Chen	DATE: 01/13/03	CAGE CODE : 32559	SHEET # 1 OF 1
CHECKED: D. Green	DATE: 01/13/03	CAD GENERATED DOCUMENT. DO NOT MEASURE DRAWING.	