

Li-ion Battery Charger

The ISL9201 is an integrated single-cell Li-ion or Li-polymer charger capable of operating at an input voltage as low as 2.5V. The low operating voltage allows the charger to work with a variety of AC adapters.

The ISL9201 operates as a linear charger when the AC adapter is a voltage source. The battery is charged in a standard Li-ion charge profile, i.e. a constant current phase followed by a constant voltage phase (CC/CV). The charge current during the constant current phase is determined by the external resistor connected to the IREF pin. When the adapter output is a current-limited voltage source and the current limit is smaller than the programmed constant current of the IC, the ISL9201 operates as a pulse charger where the charge current is determined by the current limit of the AC adapter during the constant current phase. The ISL9201 operates in a linear mode during the constant voltage phase in both adapter cases.

The ISL9201 incorporates Thermaguard™, which protects the IC against over-temperature. If the die temperature rises above a typical value of +110 °C, the thermal foldback function reduces the charge current to prevent further temperature rise. The ISL9201 also includes a timer to set the time reference for the delay time of the end-of-charge (EOC) and recharge indications. The timer is programmable with an external capacitor. A logic input and an open-drain logic output are available for controlling the charger and indicating the charger status. The EN pin enables the charger. The STATUS pin is an open-drain output which turns on when the charger is delivering current. The charger uses a 10 Ld 3x3 DFN package to maximize thermal conductivity.

Ordering Information

PART NUMBER	PART MARKING	TEMP. RANGE (°C)	PACKAGE (Pb-free)	PKG DWG. #
ISL9201IRZ	DLGA	-40 to +85	10 Ld 3x3 DFN	L10.3x3
ISL9201IRZ-T	DLGA	-40 to +85	10 Ld 3x3 DFN Tape & Reel	L10.3x3

NOTE: Intersil Pb-free plus anneal products employ special Pb-free material sets; molding compounds/die attach materials and 100% matte tin plate termination finish, which are RoHS compliant and compatible with both SnPb and Pb-free soldering operations. Intersil Pb-free products are MSL classified at Pb-free peak reflow temperatures that meet or exceed the Pb-free requirements of IPC/JEDEC J STD-020.

Features

- Complete Charger for Single-Cell Li-ion/Polymer Batteries
- Integrated Pass Element and Current Sensor
- No External Blocking Diode Required
- Low Component Count and Cost
- 25mV Voltage Accuracy Over-Temperature and Input Voltage Range
- 20mV Voltage Accuracy at Room Temperature
- Programmable Charge Current
- Charge Current Thermal Foldback for Thermal Protection (Thermaguard™)
- Trickle Charge for Fully Discharged Batteries
- Power Presence and Charge/EOC Indications
- Less than 4µA Leakage Current off the Battery when No Input Power Attached or Charger Disabled
- Ambient Temperature Range: -40°C to +85°C
- DFN Package
- Pb-Free Plus Anneal Available (RoHS Compliant)

Applications

- Mobile Phones
- Blue-Tooth Devices
- PDAs
- MP3 Players
- Stand-Alone Cradle or Travel Chargers
- Other Handheld Devices

Pinout

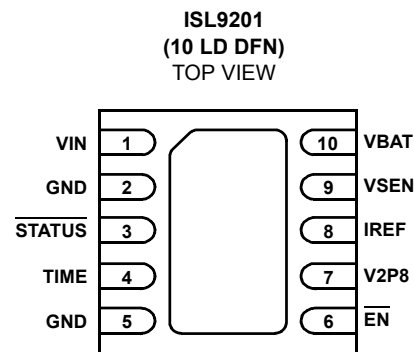

Typical Applications

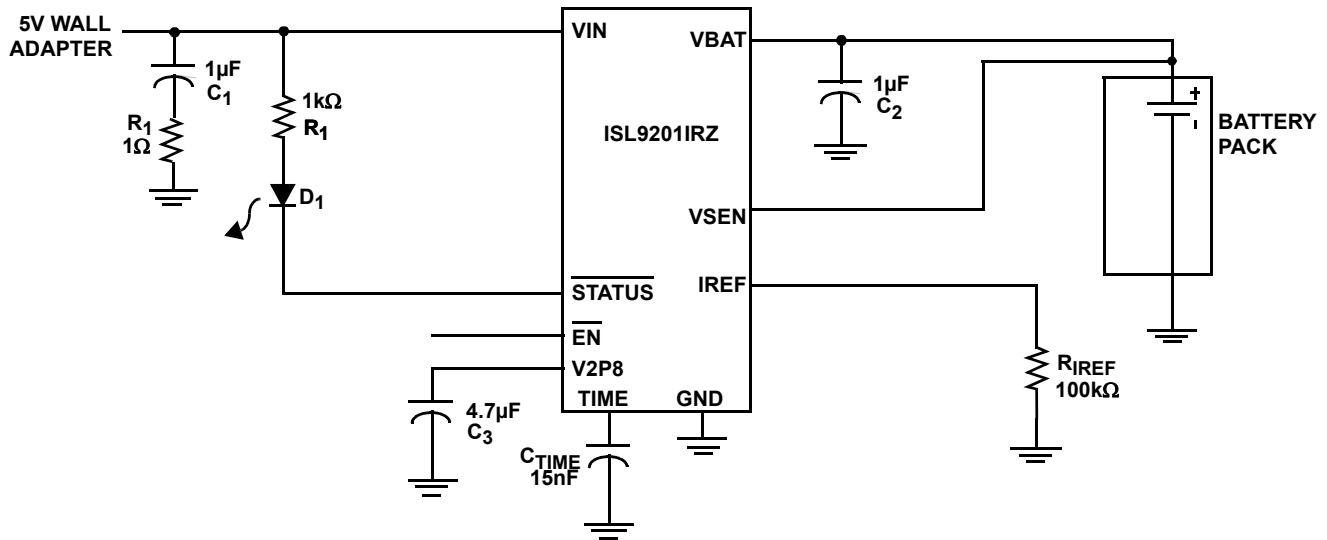

Pin Description

VIN (Pin 1)

VIN is the input power source. Connect to a wall adapter.

GND (Pin 2)

GND is the connection to system ground.

STATUS (Pin 3)

STATUS is an open-drain output indicating charging and inhibit states. The STATUS pin is pulled LOW when the charger is charging a battery. It will be turned into high impedance when the charge current drops to I_{MIN}. This high impedance state will be latched until a recharge cycle or a new charge cycle starts. When the charger is disabled, the STATUS pin outputs high impedance.

TIME (Pin 4)

The TIME pin determines the oscillation period by connecting a timing capacitor between this pin and GND. The oscillator also provides a time reference for the charger.

GND (Pin 5)

GND is the connection to system ground.

EN (Pin 6)

EN is the enable logic input. Connect the EN pin to HIGH to disable the charger. Connect the EN pin to LOW or leave it floating to enable the charger. There is an internal 400kΩ pull-down resistor at this pin.

V2P8 (Pin 7)

This is a 2.8V reference voltage output. This pin provides a 2.8V voltage source when the input voltage is above the POR threshold and outputs 0V otherwise. The V2P8 pin can be used as an indication for adapter presence.

IREF (Pin 8)

This is the charge current programming and monitoring pin. Connect a resistor between this pin and GND to set the charge current during the constant current phase, as given by Equation 1:

$$I_{REF} = \frac{80}{R_{IREF}} \quad (A) \quad (EQ. 1)$$

Where R_{IREF} is in kΩ.

VSEN (Pin 9)

VSEN is the remote voltage sense pin. Connect this pin as close to the battery positive terminal as possible. If the VSEN pin is left floating, its voltage drops to 0V and the charger operates in trickle mode.

VBAT (Pin 10)

VBAT is the connection to the battery. Typically a 10μF Tantalum capacitor is needed for stability when there is no battery attached. When a battery is attached, only a 0.1μF ceramic capacitor is required.

Absolute Maximum Ratings

Voltage Ratings for All Pins	-0.3V to 7V
Charge Current	1.0A
ESD Rating	
Human Body Model (Per EIA JESD22 Method A114-B)	2kV
Machine Model (Per EIA JED-4701 Method C-111)	200V

Thermal Information

Thermal Resistance	θ_{JA} (°C/W)	θ_{JC} (°C/W)
3x3 DFN Package (Note 1)	48	6
Maximum Junction Temperature (Plastic Package)	+150°C	
Maximum Storage Temperature Range	-65°C to +150°C	
Maximum Lead Temperature (Soldering 10s)	+300°C	

Recommended Operating Conditions

Ambient Temperature Range	-40°C to +85°C
Operating Supply Voltage (VIN Pin)	4.25V to 6.5V
Programmed Charge Current	50mA to 900mA

CAUTION: Stresses above those listed in "Absolute Maximum Ratings" may cause permanent damage to the device. This is a stress only rating and operation of the device at these or any other conditions above those indicated in the operational sections of this specification is not implied.

+150°C max junction temperature is for information purposes only. In reality, the current foldback feature will prevent the junction from rising above the typical temperature of +110°C.

- θ_{JA} is measured in free air with the component mounted on a high effective thermal conductivity test board with "direct attach" features. See Tech Brief TB379.
- For θ_{JC} , the "case temp" location is the center of the exposed metal pad on the package underside.

Electrical Specifications Typical Values Are Tested at $V_{IN} = 5V$ and $T_A = +25^\circ C$. All Maximum and Minimum Values Are Guaranteed Under the Recommended Operating Supply Voltage Range and Ambient Temperature Range, Unless Otherwise Noted.

PARAMETER	SYMBOL	TEST CONDITIONS	MIN	TYP	MAX	UNITS
POWER-ON RESET						
Rising POR Threshold	V_{POR}	$V_{BAT} = 3.0V$, use V2P8 pin to indicate the comparator output.	3.2	3.6	3.9	V
Falling POR Threshold	V_{POR}		2.25	2.5	2.7	V
VIN-BAT OFFSET VOLTAGE						
Rising Edge	V_{OS}	$V_{BAT} = 4.2V$, $I_{BAT} = 20mA$, use STATUS pin to indicate the comparator output (Note 3)	45	80	100	mV
STANDBY CURRENT						
BAT Pin Sink Current	$I_{STANDBY}$	Charger disabled or the input is floating	-	-	3.3	μA
VIN Pin Supply Current	I_{VIN}	Charger disabled	-	150	250	μA
VIN Pin Supply Current	I_{VIN}	Charger enabled	-	1.0	-	mA
VOLTAGE REGULATION						
Output Voltage	V_{CH}	Tested at 50mA load, 5V input and +25°C	4.180	4.20	4.220	V
Output Voltage	V_{CH}	-40°C < T_A < +85°C, 4.3V < V_{IN} < 6.5V	4.175	4.20	4.225	V
PMOS On Resistance	$r_{DS(ON)}$	$V_{BAT} = 4.0V$, charge current = 0.35A	-	500	-	m Ω
CHARGE CURRENT (Note 4)						
Constant Charge Current	I_{CC}	$V_{IN} = 5V$, $R_{IREF} = 887k\Omega$, $V_{BAT} = 3.0V$ to 4.0V	60	90	120	mA
		$V_{IN} = 5V$, $R_{IREF} = 100k\Omega$, $V_{BAT} = 3.0V$ to 4.0V	725	800	840	mA
Trickle Charge Current	I_{TRK}	$V_{IN} = 5V$, $R_{IREF} = 800k\Omega$, $V_{BAT} = 0V$ to 2.5V	6	10	14	mA
		$V_{IN} = 5V$, $R_{IREF} = 100k\Omega$, $V_{BAT} = 0V$ to 2.5V	64	80	96	mA
End-of-Charge Current	I_{MIN}	$R_{IREF} = 100k\Omega$	60	80	105	mA
V2P8 PIN OUTPUT						
V2P8 Pin Output Voltage	V_{V2P8}	Load current less than 1mA	2.8	2.9	3.0	V
CHARGE THRESHOLDS						
Preconditioning Charge Threshold Voltage	V_{MIN}		2.7	2.8	2.9	V
Preconditioning Voltage Hysteresis	V_{MINHYS}		50	100	150	mV

ISL9201

Electrical Specifications Typical Values Are Tested at $V_{IN} = 5V$ and $T_A = +25^{\circ}C$. All Maximum and Minimum Values Are Guaranteed Under the Recommended Operating Supply Voltage Range and Ambient Temperature Range, Unless Otherwise Noted. **(Continued)**

PARAMETER	SYMBOL	TEST CONDITIONS	MIN	TYP	MAX	UNITS
Recharge Threshold	V_{RCH}	Referenced to the charger output voltage V_{CH}	-225	-150	-70	mV
Recharge Threshold Hysteresis	V_{RCHHYS}		-	50	-	mV
INTERNAL TEMPERATURE MONITORING						
Charge Current Foldback Threshold	T_{FOLD}			110		$^{\circ}C$
OSCILLATOR						
Oscillation Period	t_{OSC}	$C_{TIME} = 15nF$	2.7	3.0	3.3	ms
LOGIC INPUT AND OUTPUTS						
\overline{EN} Pin Logic Input High			1.3	-	-	V
\overline{EN} Pin Logic Input Low			-	-	0.5	V
\overline{EN} Pin Internal Pull Down Resistance			200	400	600	$k\Omega$
\overline{STATUS} Output Voltage When On		10mA current	-	-	0.8	V
\overline{STATUS} Leakage Current		$V_{STATUS} = 6.5V$	-	-	1	μA

NOTE:

- The 4.2V V_{BAT} is selected so that the \overline{STATUS} output can be used as the indication for the offset comparator output indication. If the V_{BAT} is lower than the POR threshold, no output pin can be used for indication.
- The charge current can be affected by the thermal foldback function if the IC under the test setup cannot dissipate the heat.

Functional Block Diagram

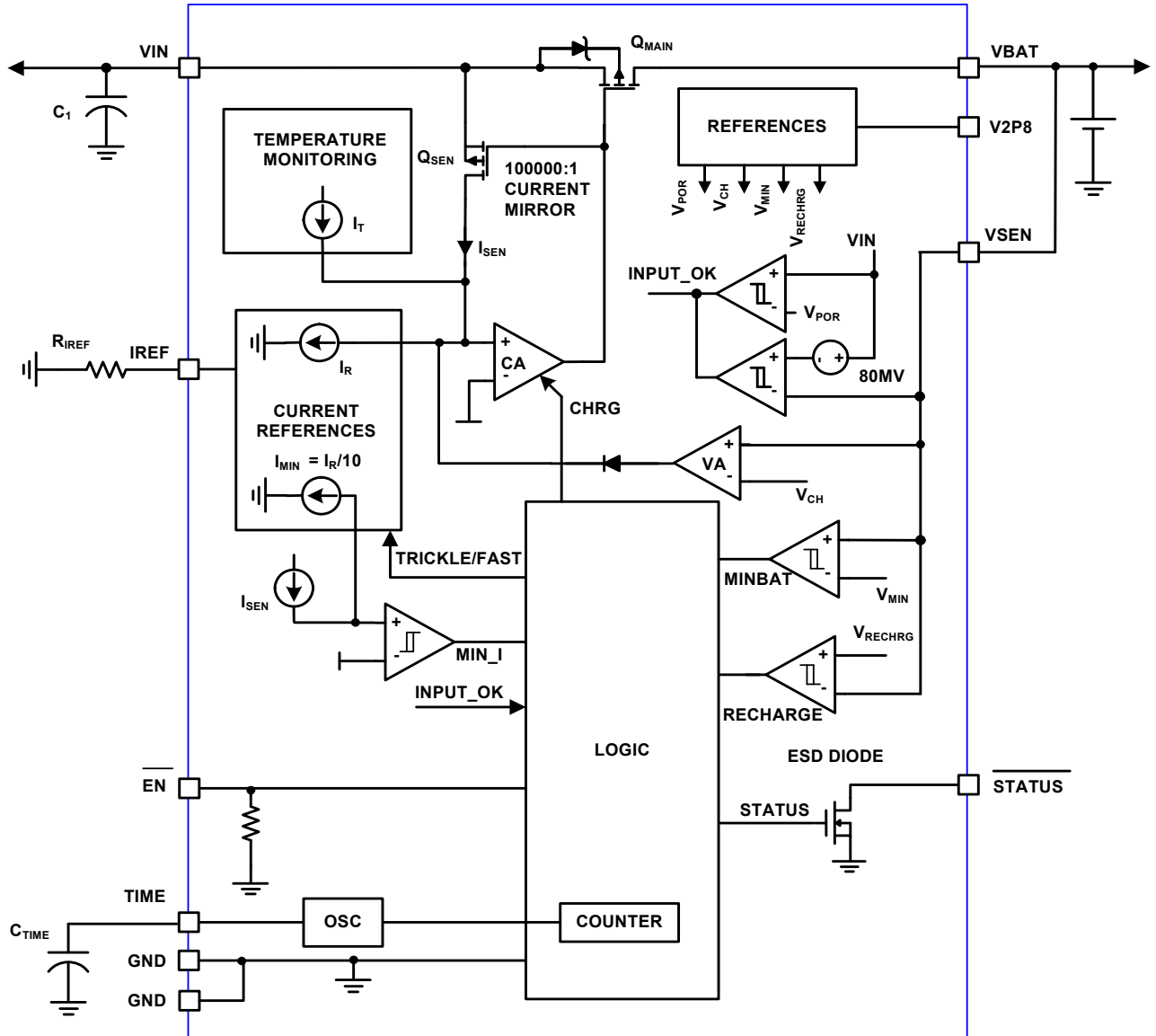

Theory of Operation

The ISL9201 is an integrated charger for single-cell Li-ion or Li-polymer batteries. The ISL9201 is capable of operating in two operation modes; linear charge mode and pulse charge mode. The ISL9201 functions as a traditional linear charger when powered with a voltage source adapter. When powered with a current-limited adapter, the charger functions as a pulse charger by fully turning on the pass element and the power dissipation is hence drastically reduced.

Constant Current Phase

The ISL9201 starts the charge at a constant current (CC) phase. The charge current is regulated to fast charge the battery before the final voltage has been reached. The charge current is programmable with the IREF pin and has two operation modes: trickle mode and constant current mode, depending on the battery voltage. When the battery voltage is lower than 2.8V, the charger operates in trickle mode where the charge current is set at 10% of the constant current mode current. The trickle mode is for preconditioning a deeply discharged battery. Once the battery voltage is above the typical 2.8V threshold, the constant current (CC) mode starts. The constant current is programmable between 50mA to 1A.

Constant Voltage Phase

When the battery reaches the final voltage, the ISL9201 switches the operation to a constant voltage (CV) phase. The output voltage is regulated at the final voltage value. During the constant voltage phase, the charge current reduces gradually as the cell voltage rises.

Charge Termination and Recharge

As the charge current reaches the EOC (end of charge) current threshold during the constant voltage phase, the STATUS pin open-drain FET is turned off to indicate an EOC condition. The EOC current is fixed at 10% of the programmed constant charge current. When the EOC condition is reached, the STATUS pin is latched at logic HIGH, the charger, however, will continue to charge the battery until the EN pin is pulled to logic HIGH or the input power has been removed. When the battery voltage falls to 150mV below the constant voltage value, the STATUS latch will be reset and open-drain FET is turned on to indicate a charging condition again. An internal delay is implemented at the STATUS pin for both EOC and recharge conditions to prevent nuisance trips due to noise and fast load current transitions. The delay time is approximately one clock cycle (varies between 0.5 and 1.5 clock) of the internal oscillator, which is programmed by the timer capacitor. The typical charge waveforms in Figure 1 show the complete cycle operation.

Thermal Foldback

In the event where the die temperature reaches the thermal foldback threshold (+110°C typical), the charge current is reduced accordingly to prevent further temperature rise.

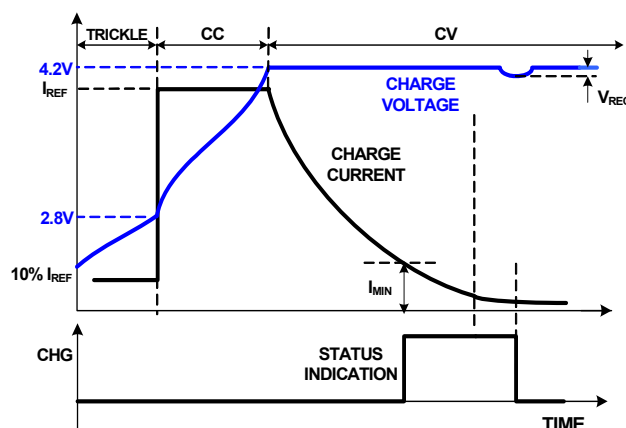

FIGURE 1. TYPICAL CHARGE CYCLE WITH TIMEOUT

POR

The power-on reset (POR) function monitors the supply voltage. The POR has a rising edge threshold of 3.6V typical and 2.5V typical for falling edge. The charger is expected to operate when the input voltage is above the POR threshold. After POR the charger will continue to operate for supply voltage down to 2.5V typical. It is also required that the supply voltage be higher than the VBAT pin voltage by a typical 80mV for the charger to function.

Oscillator

The ISL9201 incorporates with an oscillation circuit using an external timing capacitor connected to the TIME pin. The oscillator sets the delay time for the STATUS indication for EOC and recharge conditions to prevent nuisance trip due to in-rush currents.

Indications

The ISL9201 has an open-drain status indication pin. The STATUS pin requires an external pull-up resistor to function properly. The V2P8 pin can be used as the presence of AC adapter.

Charger Disable

The EN pin allows the user to disable the charger. When the charger is disabled, all internal circuits are shut down and the quiescent current at the input pin is less than 150µA typical.

Remote Battery Voltage Sensing

A kelvin sense pin is provided for battery terminal voltage monitoring. Thus, the IR drop due to the connection leads and PCB traces can be eliminated, resulting in a more accurate battery voltage monitoring, especially when the battery is located at a significant distance away from the ISL9201. If remote sensing is not needed, the VSEN pin can be connected to VBAT at the IC.

Applications Information

PCB Layout Guidance

The ISL9201 uses a thermally-enhanced DFN package that has an exposed thermal pad at the bottom side of the package. The layout should connect as much as possible to copper on the exposed pad. Typically, the component layer is more effective in dissipating heat. The thermal impedance can be further reduced by using other layers of copper connecting to the exposed pad through a thermal via array. A minimum of four (4) such thermal vias are recommended. Each thermal via is recommended to have 0.3mm diameter and 0.7mm distance from other thermal vias.

Stability Consideration

The ISL9201 should behave like a current and thermal limited linear regulator. The charger operation is stable with an output ceramic decoupling capacitor in the range of 1 μ F to 200 μ F, with or without a battery connected.

Input Bypass Capacitor

Due to the inductance of the power leads of the wall adapter or USB source, the input capacitor type must be properly selected to prevent high voltage transient during a hot-plug event. A tantalum capacitor is a good choice for its high ESR, providing damping to the voltage transient. Multi-layer ceramic capacitors, however, have a very low ESR and hence when chosen as input capacitor, a 1- Ω series resistor must be used, as shown in the "Typical Applications" on page 2, to provide adequate damping.

State Machine Diagram

The state machine diagram is shown in Figure 2. The diagram starts with the Power-Off state. When the input voltage rises above the POR threshold, the charger resets itself. Then, if the charger is disabled, the charger stays in the Charger Disabled state. If the charger is enabled, the trickle charge starts. Anytime when V_{BAT} is above the preconditioning charge threshold voltage, the charger enters the fast charge state. When V_{BAT} reaches 4.2V, the charger enters a constant voltage state where V_{BAT} is regulated at 4.2V. When the charge current decays to the I_{MIN} threshold, the STATUS indicates an EOC condition. This condition is latched until either the EN pin is toggled or a POR condition has occurred at V_{IN} .

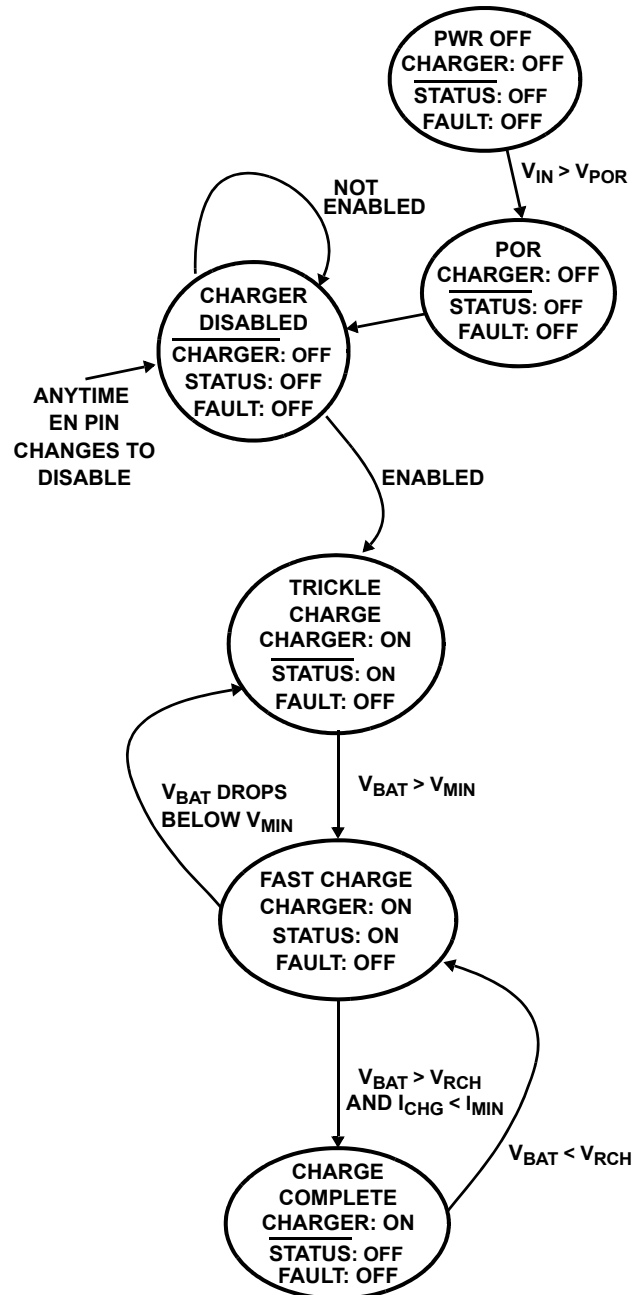
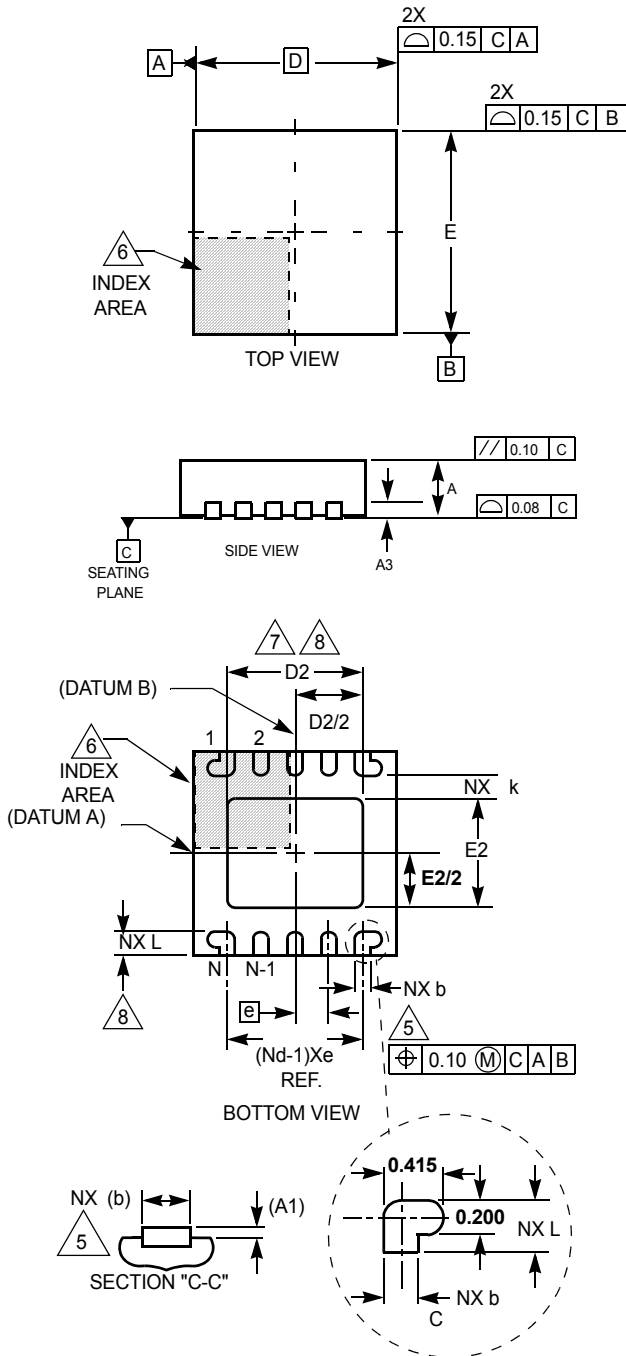

FIGURE 2. STATE MACHINE DIAGRAM

Dual Flat No-Lead Plastic Package (DFN)



L10.3x3
10 LEAD DUAL FLAT NO-LEAD PLASTIC PACKAGE

SYMBOL	MILLIMETERS			NOTES
	MIN	NOMINAL	MAX	
A	0.80	0.90	1.00	-
A1	-	-	0.05	-
A3	0.20 REF			-
b	0.18	0.23	0.28	5,8
D	3.00 BSC			-
D2	1.95	2.00	2.05	7,8
E	3.00 BSC			-
E2	1.55	1.60	1.65	7,8
e	0.50 BSC			-
k	0.25	-	-	-
L	0.30	0.35	0.40	8
N	10			2
Nd	5			3

Rev. 3 6/04

NOTES:

1. Dimensioning and tolerancing conform to ASME Y14.5-1994.
2. N is the number of terminals.
3. Nd refers to the number of terminals on D.
4. All dimensions are in millimeters. Angles are in degrees.
5. Dimension b applies to the metallized terminal and is measured between 0.15mm and 0.30mm from the terminal tip.
6. The configuration of the pin #1 identifier is optional, but must be located within the zone indicated. The pin #1 identifier may be either a mold or mark feature.
7. Dimensions D2 and E2 are for the exposed pads which provide improved electrical and thermal performance.
8. Nominal dimensions are provided to assist with PCB Land Pattern Design efforts, see Intersil Technical Brief TB389.

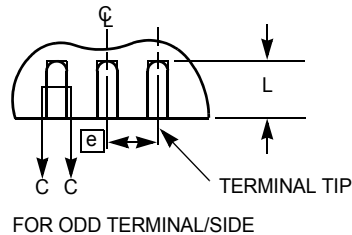

All Intersil U.S. products are manufactured, assembled and tested utilizing ISO9001 quality systems. Intersil Corporation's quality certifications can be viewed at www.intersil.com/design/quality

Intersil products are sold by description only. Intersil Corporation reserves the right to make changes in circuit design, software and/or specifications at any time without notice. Accordingly, the reader is cautioned to verify that data sheets are current before placing orders. Information furnished by Intersil is believed to be accurate and reliable. However, no responsibility is assumed by Intersil or its subsidiaries for its use; nor for any infringements of patents or other rights of third parties which may result from its use. No license is granted by implication or otherwise under any patent or patent rights of Intersil or its subsidiaries.

For information regarding Intersil Corporation and its products, see www.intersil.com