

LOC		DIST		REVISIONS			
P	LTR	DESCRIPTION	DATE	DN	APVD		
D		REV PER ECO 09-014927	6-24-09	CT	DM		

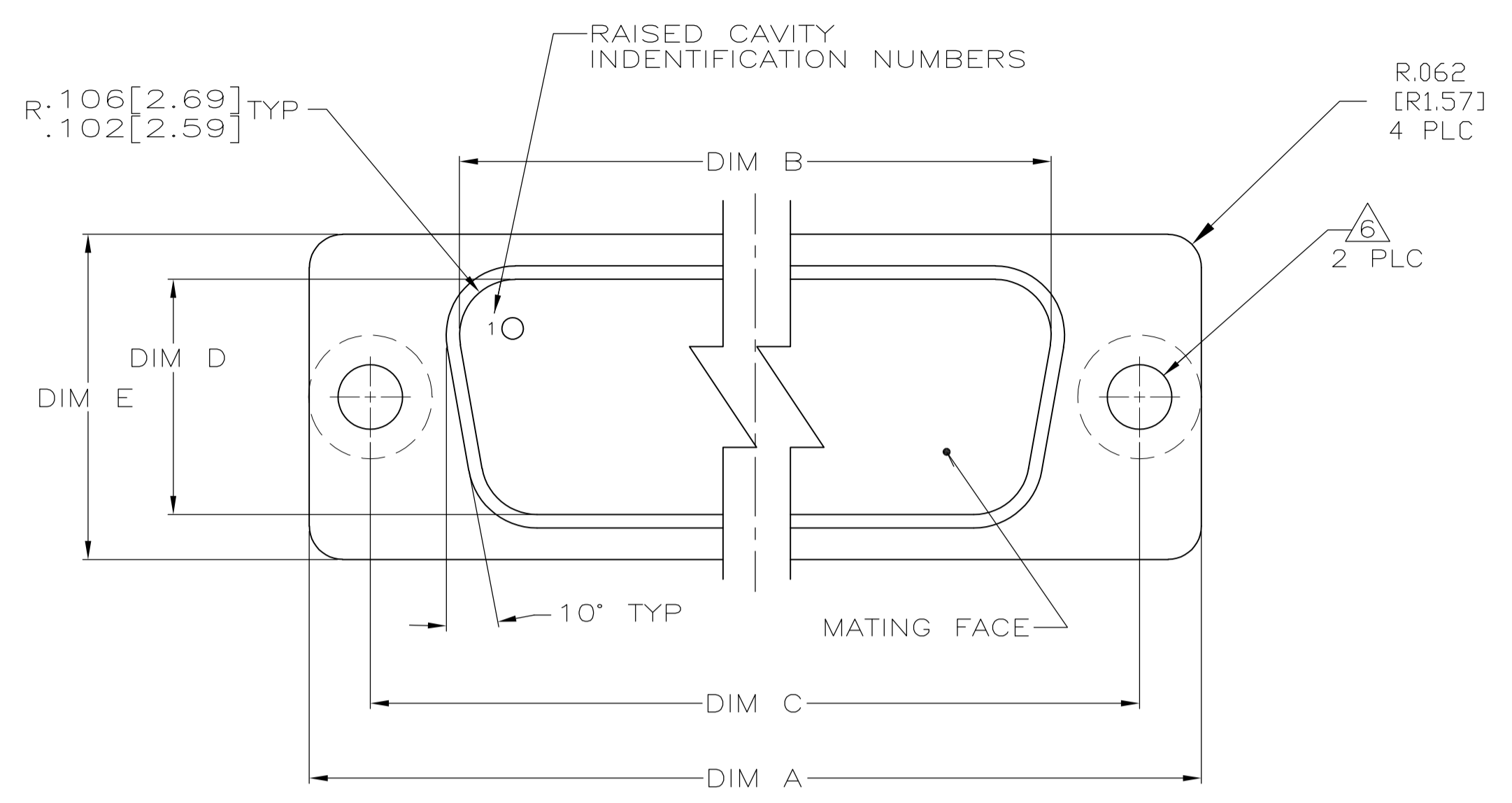

- CONNECTOR (S) WILL BE TESTED IN ACCORDANCE WITH GROUP A INSPECTION OF NASA SPEC S-311-P-4, RESIDUAL MAGNETISM IS NOT REQUIRED.
  - THIS CONNECTOR ASSEMBLY MATES WITH ANY MIL-PRF-24308 RECEPTACLE CONNECTOR WITH SAME INSERT ARRANGEMENT.
  - MARKED WITH .047 [1.19]-.062 [1.57] HIGH CHARACTERS. FAR SIDE REFERS TO THE WIDE SIDE OF THE KEYSTONE. NEAR SIDE REFERS TO THE NARROW SIDE OF THE KEYSTONE. IF THE SHELL IS TOO SMALL FOR ALL THE INFORMATION THEN MARKING MAY BE SPLIT BETWEEN FRONT AND REAR, FAR SIDE.
  - RETENTION SPRING MATERIAL: BERYLLIUM COPPER PER ASTM B 194.
  - THIS DRAWING SHALL BE INTERPRETED IN ACCORDANCE WITH APPLICABLE STANDARDS LISTED IN MIL-STD-100.
- 6 .112-40UNC-2B HELICOIL INSERT PER NAS1130-04-15. NO PLATING IS REQUIRED PRIOR TO OR POST INSTALLATION OF THE HELICOIL INSERT.
- 7 A DUST COVER IS ASSEMBLED ON EACH CONNECTOR.

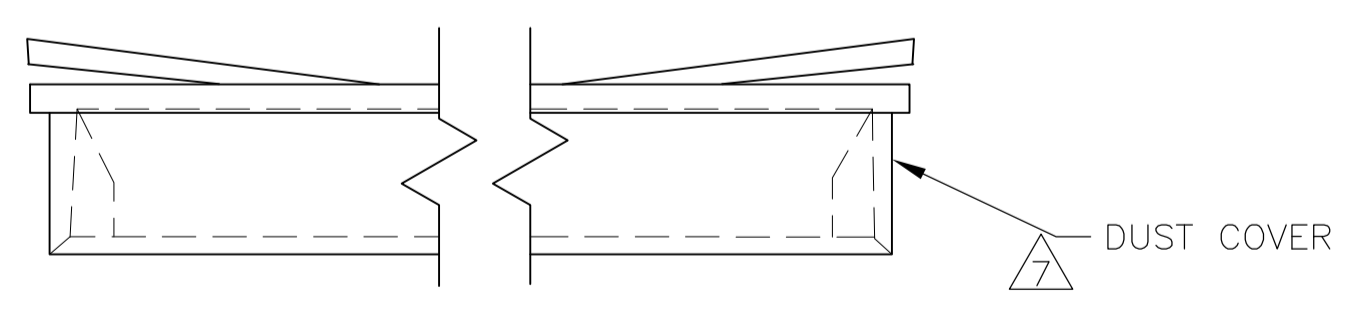
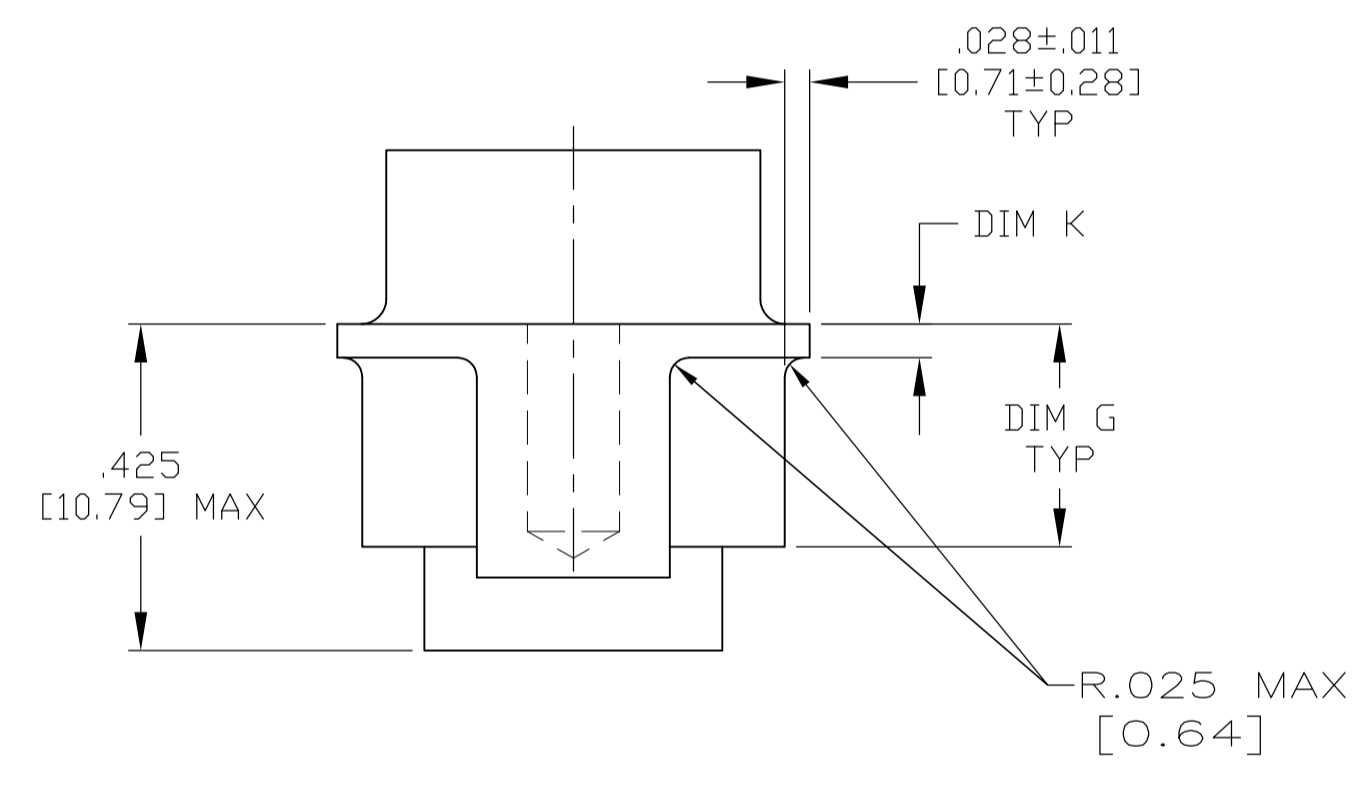
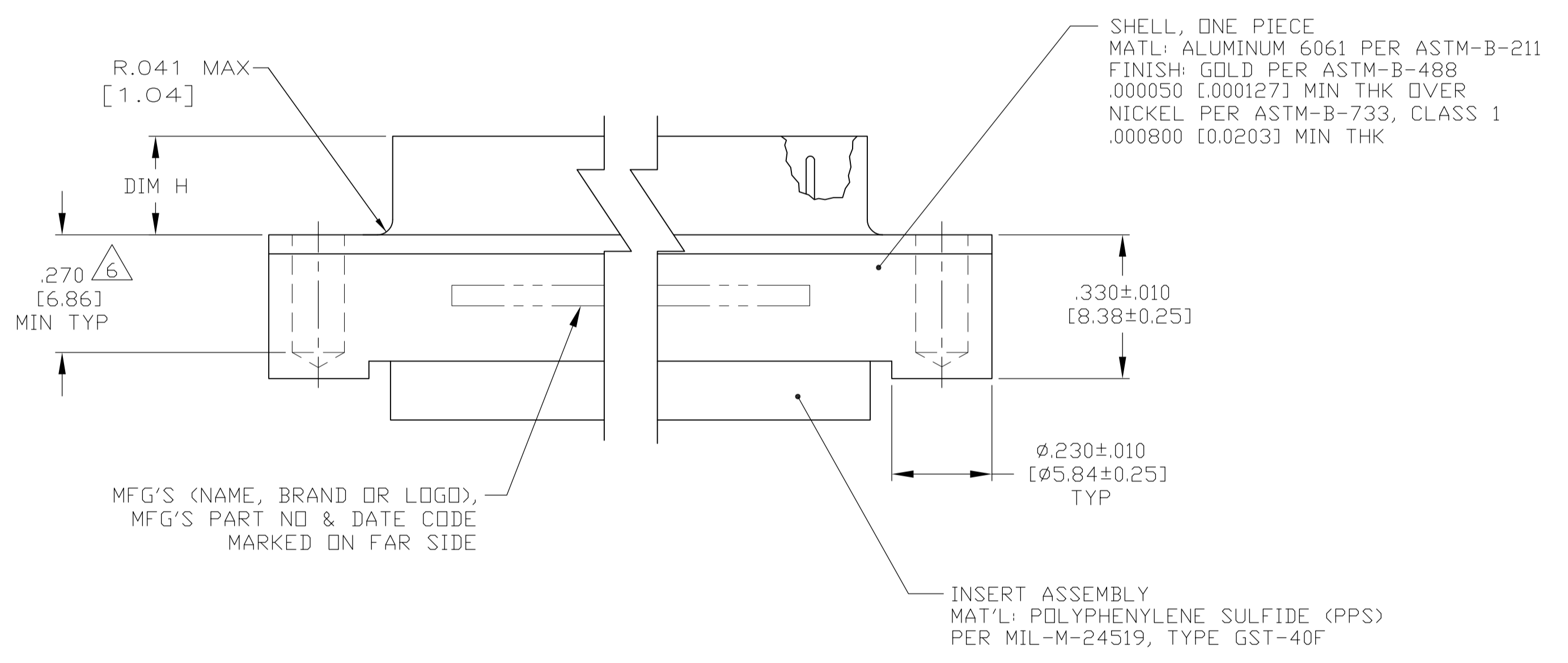

.044	.236 [5.99]	.299	.610 [15.49]	.446 [11.33]	2.411 [61.24]	2.084 [52.93]	2.640 [67.06]	MS18277-2	78	5	1883055-5
[1.12]	[5.99]	[7.59]	[15.24]	[11.07]	[60.99]	[52.68]	[66.80]				
.044	.236 [5.99]	.299	.499 [12.67]	.334 [8.48]	2.505 [63.63]	2.187 [55.55]	2.734 [69.44]	MS18276-2	62	4	1883055-4
[1.12]	[5.69]	[7.59]	[12.42]	[8.23]	[63.37]	[55.30]	[69.20]				
.044	.236 [5.99]	.299	.499 [12.67]	.334 [8.48]	1.857 [47.17]	1.539 [39.09]	2.093 [53.16]	MS18275-2	44	3	1883055-3
[1.12]	[5.69]	[7.59]	[12.42]	[8.23]	[46.91]	[38.84]	[52.91]				
.035	.241 [6.12]	.294	.499 [12.67]	.334 [8.48]	1.317 [33.45]	.999 [25.37]	1.546 [39.27]	MS18274-2	26	2	1883055-2
[0.89]	[5.82]	[7.47]	[12.42]	[8.23]	[33.20]	[25.12]	[39.01]				
.035	.241 [6.12]	.294	.499 [12.67]	.334 [8.48]	.989 [25.12]	.671 [17.04]	1.218 [30.94]	MS18273-2	15	1	1883055-1
[0.89]	[5.82]	[7.47]	[12.42]	[8.23]	[24.87]	[16.79]	[30.68]				
K	H	G±.010 [±0.25]	E	D	C	B	A	INSERT ARRANGEMENT	NO OF POS	SHELL SIZE	MFG'S PART NUMBER

THIS DRAWING IS A CONTROLLED DOCUMENT.

DIMENSIONS: INCHES	TOLERANCES UNLESS OTHERWISE SPECIFIED:	DIN C.C. THOMAS 10-24-05	APPROVED D. MILLER 10-24-05	NAME D. MILLER
0 PLC ± -	1 PLC ± -	2 PLC ± -	3 PLC ± .005(0.13)	4 PLC ± -
ANGLES ± -				
MATERIAL SEE CALLOUT	FINISH SEE CALLOUT	WEIGHT -	SIZE A1	CAGE CODE 00779
CUSTOMER DRAWING		SCALE 4:1	SHEET 1 OF 1	REV D

AMPLIMITE PLUG ASSEMBLY  
 SERIES 90, CRIMP, ONE  
 PIECE SHELL SIZE 1 THRU 5

Tyco Electronics Corporation  
 Harrisburg, PA 17105-3608