

PART NUMBER	REV	TERMINATOR	FEED TYPE	DESCRIPTION
1528565-1	C	LEADMAKER	MECH POST FEED	CUTS CARRIER
1528565-2	C	BENCH	MECH PRE FEED	CUTS CARRIER
1528565-6	C	LEADMAKER	MECH POST FEED	CONTINUOUS CARRIER
7-1528565-1	C	LEADMAKER	MECH POST FEED	-1 AND SPARE PARTS
7-1528565-2	C	BENCH	MECH PRE FEED	-2 AND SPARE PARTS
7-1528565-6	C	LEADMAKER	MECH POST FEED	-6 AND SPARE PARTS
7-1528565-7	A	-	-	SPARE PARTS KIT

CRIMP DATA		KOSTAL TERMINAL		TE CRIMP SPEC	
TERMINAL NAME: KOSTAL PIN CONTACT					
CRIMP	SIZE	TYPE	RANGE		
WIRE	1.85 [.073 IN]	F	0.75-1.00mm ²		
INSUL	3.94 [.155 IN]	O	3.40 MAX [.134 IN MAX]		
WIRE STRIP LENGTH		APPL INSTRUCTIONS			
3.90-4.70 mm [.154-.185 IN]		408-8322 & 408-8490			
TERMINAL APPL SPEC		NONE	FEED		13.00 [.512 IN]
TERMINALS APPLIED					
TE PN	MANUF PN	TE SEAL PN	MANUF SEAL PN		
1572809-1	10140444690	1572281-1	10800444522		
1572810-1	22124444630	957402-1	10800444522		
1572809-2	10124444690	-	-		
WIRE SIZE	CRIMP HEIGHT	REF SETTING			
1.00mm ²	1.45 ± 0.05 [.057 ± .002 IN]	B 7			
0.75mm ² or 18AWG	1.37 ± 0.05 [.054 ± .002 IN]	C 2			

- △ RECOMMENDED SPARE PARTS
- 2. GREASE RAM, CAM, CAM FOLLOWER AND FEED ROD LIGHTLY
- 3. LUBRICATE DAILY PER THE APPLICATOR INSTRUCTION SHEET SUPPLIED WITH THE APPLICATOR
- △ THIS APPLICATOR APPLIES TERMINAL WITH A SEAL. INSULATION DIA QUOTED IS OUTSIDE DIAMETER OF SEAL. WIRE INSULATION DIA IS DEPENDENT ON SEAL BEING APPLIED. SEAL PN -1 0800 44452 2 INS. DIA RANGE IS -1.1-2.0 [.043-.079 IN]. (TERMINAL INS RANGE = 1.4-2.0 [.055-.079]).
- △ APPLY TORQ-SEAL IN ALLEN SOCKET TO FILL HOLE AFTER FLAT HD HAS BEEN ADJUSTED TO CORRECT HEIGHT AT QUALIFICATION. APPLY #1-23419-5 LOC-TITE TO THREADS.
- △ ALL CRIMP DATA CALCULATED BY TYCO ELECTRONICS UK LTD.
- △ ENVELOPE DRGS. 1572281-1 & 957402-1 BOTH REFER TO KOSTAL SEAL P/N 1 0800 44452 2.

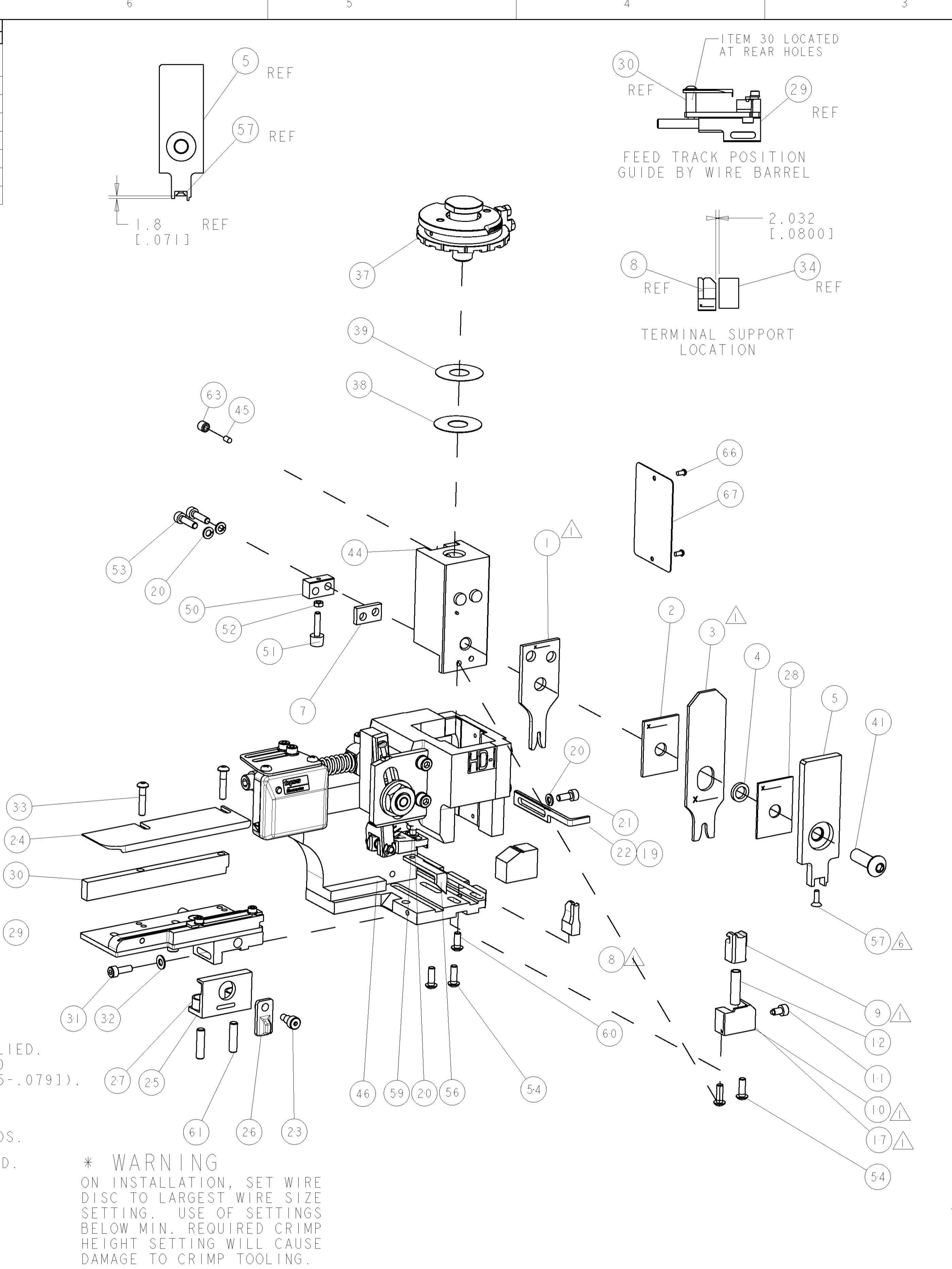
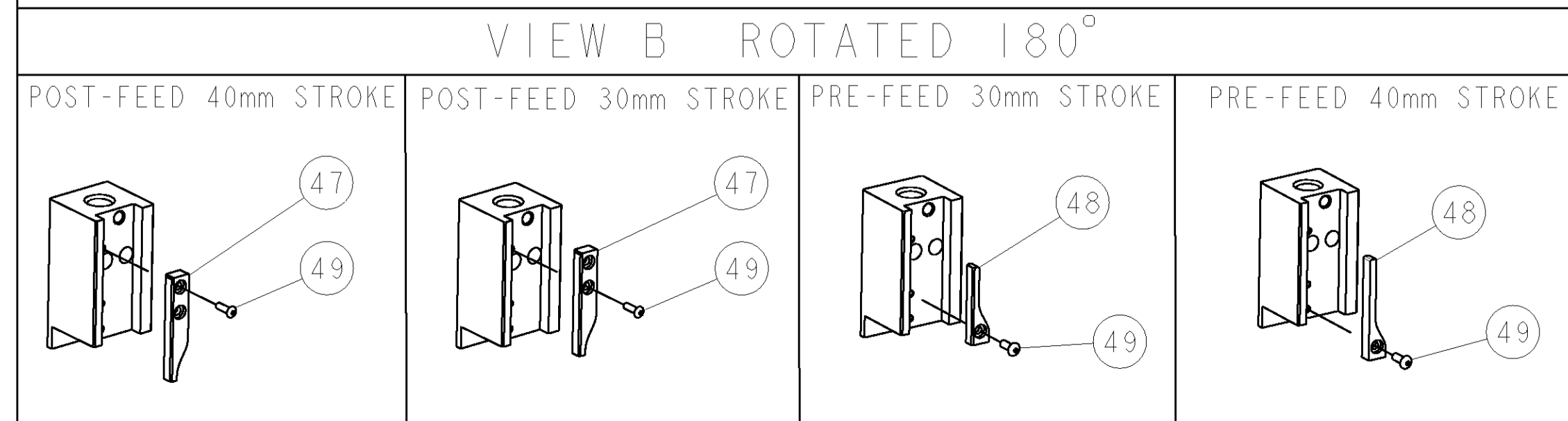

* WARNING
ON INSTALLATION, SET WIRE DISC TO LARGEST WIRE SIZE SETTING. USE OF SETTINGS BELOW MIN. REQUIRED CRIMP HEIGHT SETTING WILL CAUSE DAMAGE TO CRIMP TOOLING.

ITEM NO	PART NO	DESCRIPTION
83		
82		
81		
80		
79		
78		
77		
76		
75		
74		
ITEM NO	PART NO	DESCRIPTION
-77	-76	-72
-71	-6	-2
-1		

LOC	DIST	REV	DATE	BY	APPV
A	66		19SEP2005	LJL	FB
			19FEB2009	DWW	DWW
			19JUN2009	MY	GB
			11NOV2009	MY	TE

ITEM NO	PART NO	DESCRIPTION
73		
72		
71	1338705-3	DOCUMENTATION PACKAGE
70		
69		
68		
67	461264-5	PLATE, IDENTIFICATION
66	21017-2	SCREW, DRIVE
65		
64		
63	3-18031-0	SCR, SET, CUP POINT M6 X 6.0
62		
61	2-18032-5	SCR, SET, FLT POINT M5 X 20.0
60	18024-7	SCR, BTN SKT HD CAP (M4 X 10.0)
59	5-18022-2	SCR, HEX HD CAP M4 X 8.0
58		
57	985575-3	SCR, FLT SKT HD CAP M3 X 10.0
56	1338685-1	PAWL, FEED
55		
54	18024-8	SCR, BTN SKT HD CAP (M4 X 12.0)
53	1-18023-3	SCR, SKT HD CAP M4 X 16.0
52	18030-1	NUT, HEX, REG M3
51	811242-5	BUMPER, HOLD DOWN
50	690753-2	SPACER, TONKER
49	18024-3	SCR, BTN SKT HD CAP (M3 X 10.0)
48	1338675-1	CAM, UNIVERSAL PRE FEED
47	1338676-1	CAM, UNIVERSAL POST-FEED
46	1320999-3	APPLICATOR SUBASSEMBLY, HDI
45	690191-1	PLUG, NYLON
44	1338660-1	RAM
43		
42		
41	2-18024-6	SCR, BTN SKT HD CAP (M8 X 25.0)
40		
39	690125-1	SHIM SUB-ASSY
38	1-469367-0	SHIM
37	879103-2	FINE ADJUST HEAD SUBASSY
36		
35		
34	1424186-2	SUPPORT, TERMINAL
33	1-18024-0	SCR, BTN SKT HD CAP (M4 X 20.0)
32	18027-2	WASHER, FLAT, REG M4
31	1-18023-2	SCR, SKT HD CAP M4 X 12.0
30	1320908-1	SPACER, STRIP GUIDE
29	1633073-2	STRIP GUIDE ASSEMBLY
28	1-455888-0	SPACER, CRIMPER
27	1-22284-0	SPRING, COMPRESSION
26	356835-1	LEVER, DRAG RELEASE
25	240792-1	DRAG, TERMINAL
24	1320928-1	PLATE, STRIP GUIDE
23	980371-4	SCR, SKT HD SHLDR 5.0 DIA X 6.0
22	690472-2	STRIPPER
21	1-18023-1	SCR, SKT HD CAP M4 X 10.0
20	18025-2	WASHER, SPRG LOCK, REG M4
19	690472-1	STRIPPER
18		
17	1338684-2	HOLDER, SHEAR, NO-CUT
16		
15		
14		
13		
12	3-22280-3	SPRING, COMPRESSION
11	356885-5	STOP, SHEAR
10	1-1320921-0	SHEAR HOLDER, FRONT, CUT
9	318707-1	FLOATING SHEAR, FRONT
8	5-1333225-3	ANVIL, COMBINATION
7	240641-8	SPACER
6		
5	1338680-1	DEPRESSOR, SHEAR
4	238011-8	BLOCK, CRIMPER SPACER
3	5-456135-4	CRIMPER, INSULATION O PREMIUM
2	1-455888-7	SPACER, CRIMPER
1	5-1490019-5	CRIMPER, WIRE PREMIUM

THIS DRAWING IS UNPUBLISHED. RELEASED FOR PUBLICATION.

TYCO ELECTRONICS CORPORATION, ALL RIGHTS RESERVED.

LOC: A DIST: 66

REVISIONS:

REV	DATE	BY	APPV
A	19SEP2005	LJL	FB
A1	19FEB2009	DWW	DWW
B	19JUN2009	MY	GB
C	11NOV2009	MY	TE

SET UP GAGE 458637-3

ITEM NO: 77-76-72-71-6-2-1

PART NO: A1 00779

DESCRIPTION: FINE ADJUST SIDE FEED HDI APPLICATOR

SCALE: 3:5 SHEET 1 OF 1 REV C

CUSTOMER ACCESSIBLE PRODUCTION DRAWING