

DRAWING REVISIONS (RELEASE DATE ON FILE)			
REV	DOCUMENT	APP	APPROVAL DATE
J	PER C.O. # 988	V.R.	04/21/10

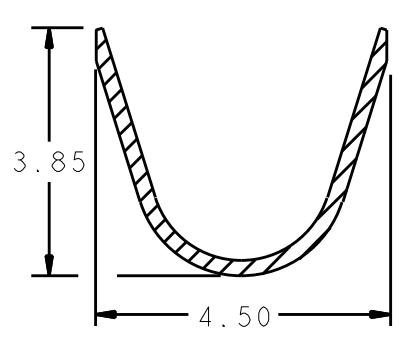

SECTION C-C

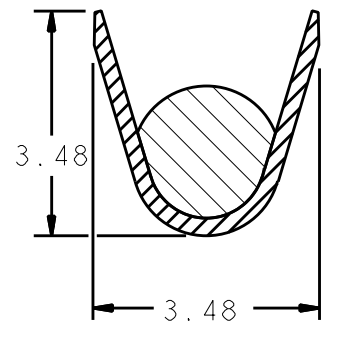

SECTION D-D

P/N 4250000873

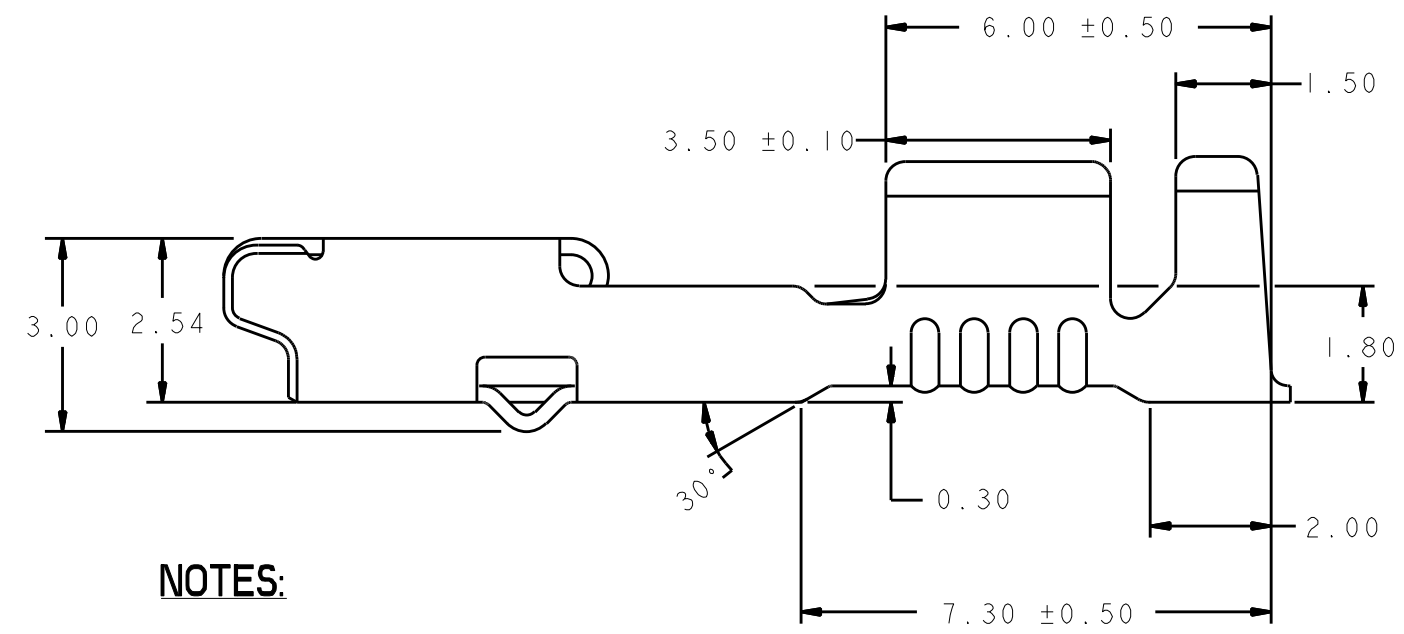
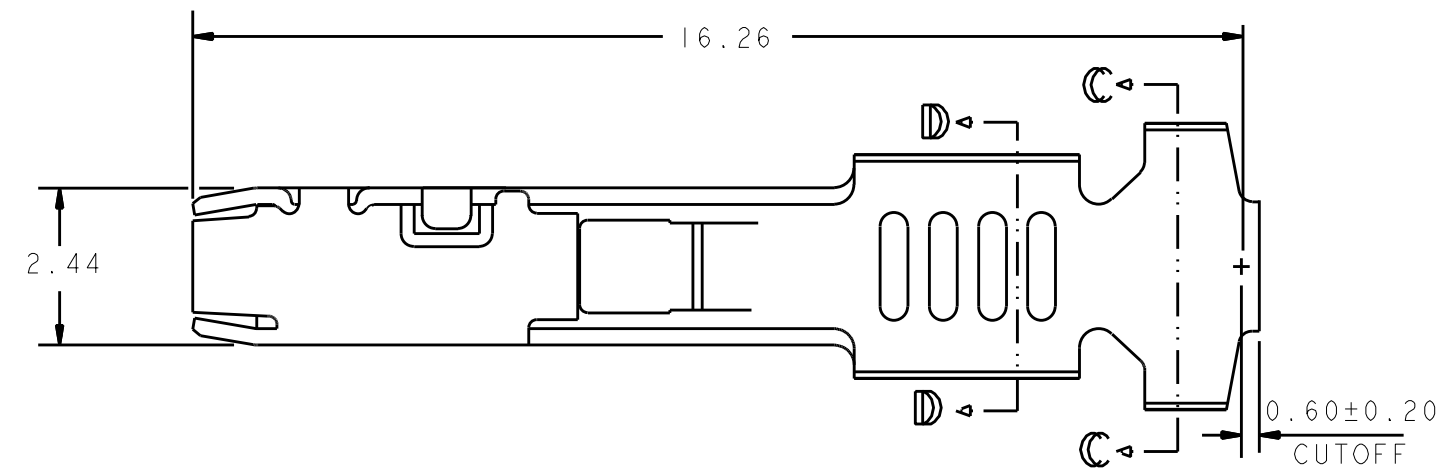
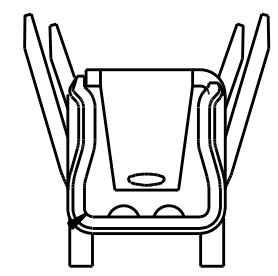

NOTES:

1. TERMINAL MATERIAL: HIGH PERFORMANCE COPPER BASED ALLOY.
2. TERMINAL PRE-PLATED 1.0 MIN MICRON THICKNESS 100% TIN (Sn) OVERALL.
3. TERMINALS SUPPLIED 3,500 EA. PER REEL.
4. TOLERANCES UNLESS OTHERWISE NOTED:
X.X ± 0.5
X.XX ± 0.30
5. ALL DIMENSIONS IN MM UNLESS OTHERWISE SPECIFIED.

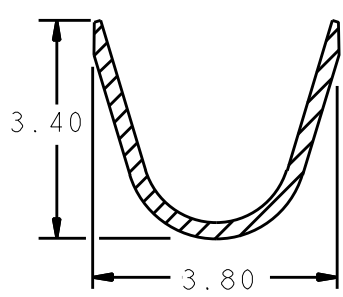

SECTION C-C

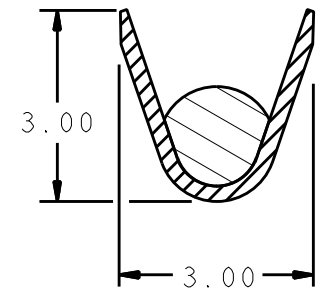

SECTION D-D

P/N 4250000872

UNITS METRIC DO NOT SCALE DRAWING UNLESS OTHERWISE SPECIFIED: ALL DIMENSIONS ARE IN mm FILLET/RADIUS 0.50 MAX. TOLERANCES X ± 0.3 XX ± 0.13 XXX ± 0.025 ANGULAR ± 0.5 CONFIDENTIAL THIS DOCUMENT IS THE PROPERTY OF CINCH. NEITHER THIS DOCUMENT NOR ANY OF THE INFORMATION CONTAINED IN IT MAY BE DUPLICATED OR DISCLOSED WITHOUT PRIOR WRITTEN CONSENT OF CINCH. ©COPYRIGHT 2010 CINCH	PRO/E DESIGN ENGINEER R. BYCZEK	DATE 12/21/99	MODELED BY: NAME CINCH 1700 FINLEY RD LOMBARD, IL 60148
	APPROVALS ON FILE		TITLE FEMALE TERMINAL BIR 16/20 AWG UNIVERSAL
MATERIAL SEE NOTES		CONTROL SPEC NUMBER -	
MATERIAL SPEC NUMBER -		PROJECT NUMBER A14243	
CAD FILE NUMBER 4250000872S		DRAWING NUMBER 4250000872S	
CAGE IDENT NO. 71785		SCALE 1:1	
SIZE B		SHEET 1 OF 2	

STRIP AND CRIMP SPECIFICATIONS

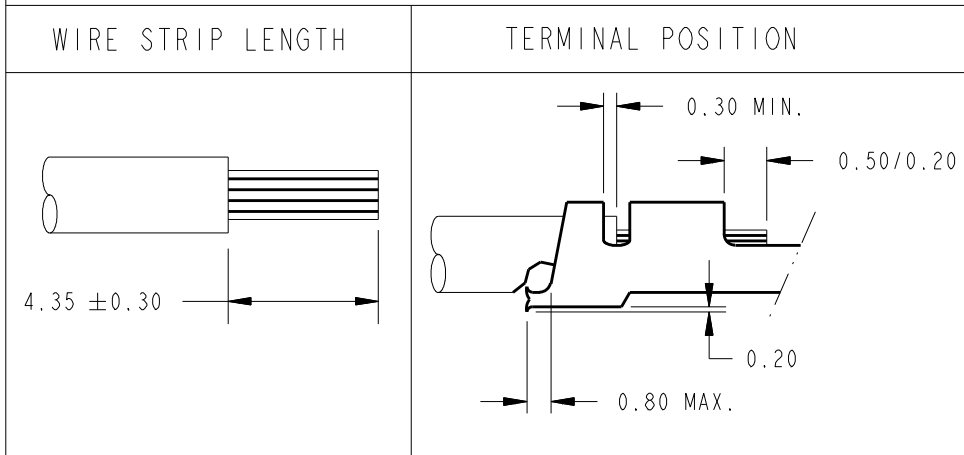

DIMENSIONS AFTER CRIMPING

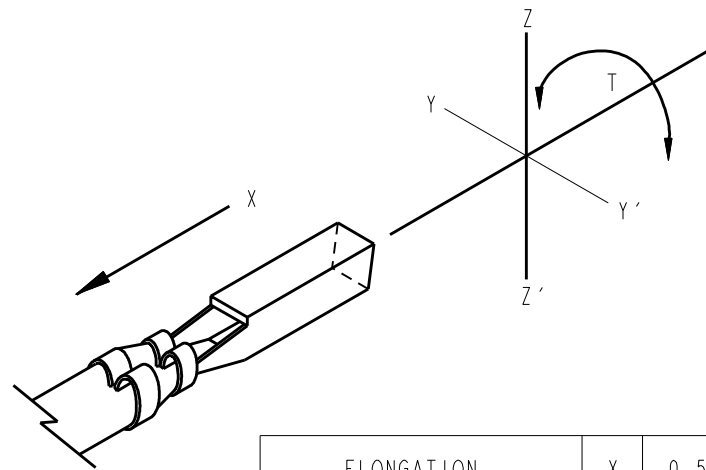

ELONGATION	X	0.50 MAX.
DEFORMATION	Y	3° MAX.
DEFORMATION	Y'	3° MAX.
FLEX	Z	2° MAX.
FLEX	Z'	3° MAX.
TORSION	T	3° MAX.

NOTES:

- ALL DIMENSIONS IN MILLIMETERS, EXCEPT WHEN SHOWN IN PARENTHESES "()", DIMS ARE IN INCHES.
- ALL FORCES: POUNDS
- CONTACT PART NUMBER: 4250000872/873
- NO WARRANTY OR GUARANTEE EXPRESSED OR IMPLIED IS MADE REGARDING THE INFORMATION PRESENTED HEREIN. IT IS, HOWEVER, TRUE AND ACCURATE TO THE BEST OF OUR KNOWLEDGE.
- PRODUCT NOT RATED FOR 14 AWG AMPERAGE (10+ AMPS), HOWEVER CAN BE USED FOR VOLTAGE DROP ONLY.

CRIMP DIMENSIONS

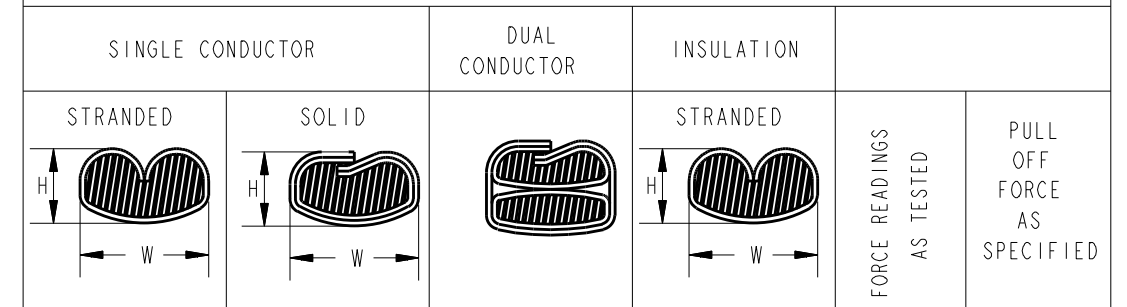

WIRE						CRIMP DIMENSIONS										
WIRE TYPE			INSULATION			TERMINAL PART NUMBER	SINGLE CONDUCTOR		DUAL CONDUCTOR		INSULATION		FORCE READINGS AS TESTED		PULL OFF FORCE AS SPECIFIED	
mm ²	AWG	NUMBER OF STRANDS	TYPE	MAX. DIA.	MIN. DIA.		H	W	H	W	H	W	AVG.	MIN.	MIN.	
.5	20	7	GXL	2.11 (.083)	2.03 (.080)	425 00 00 872	1.10	2.04			2.50	2.58	37	36	14.8	
.5	20	19	GXL	2.34 (.092)	2.18 (.086)	425 00 00 872	1.10	2.04			2.40	2.55				
.8	18	19	TXL	2.12 (.083)	1.96 (.077)	425 00 00 872	1.20	2.05			2.45	2.55				
.8	18	19	GXL	2.42 (.095)	2.26 (.089)	425 00 00 873	1.20	2.23			2.55	2.82	49	47	19.8	
.8	18	16	TXL	2.12 (.083)	1.96 (.077)	425 00 00 872	1.18	2.05			2.35	2.50				
.8	18	16	GXL	2.42 (.095)	2.26 (.089)	425 00 00 873	1.18	2.23			2.45	2.80	43	37	19.8	
1.0	16	19	TXL	2.25 (.089)	2.09 (.082)	425 00 00 873	1.30	2.26			2.55	2.88				
1.0	16	19	GXL	2.64 (.104)	2.48 (.098)	425 00 00 873	1.30	2.26			2.58	2.88	62	58	27.0	
⑤ 2.0	14	19	TXL	2.66 (.105)	2.50 (.098)	425 00 00 873	1.58	2.29			2.60	2.94			62	

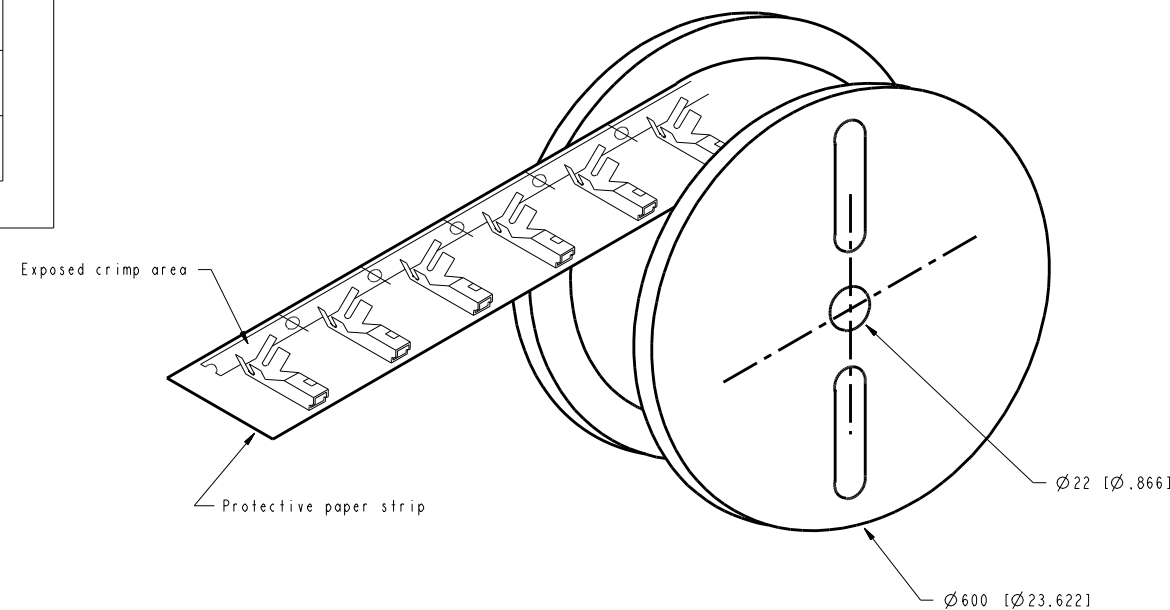

UNITS	METRIC	CINCH	1700 FINLEY RD LOMBARD, IL. 60148
DO NOT SCALE DRAWING		TITLE	
UNLESS OTHERWISE SPECIFIED: ALL DIMENSIONS ARE IN mm		FEMALE TERMINAL BIR 16/20 AWG UNIVERSAL	
FILLET/RADI 0.50 MAX.		PRO/E DRAWING	
TOLERANCES X ± 0.3 XX ± 0.13 XXX ± 0.025 ANGULAR ± 0.5°		CAD FILE NUMBER	DRAWING NUMBER
CONFIDENTIAL THIS DOCUMENT IS THE PROPERTY OF CINCH. NEITHER THIS DOCUMENT NOR ANY OF THE INFORMATION CONTAINED IN IT MAY BE DUPLICATED OR DISCLOSED WITHOUT PRIOR WRITTEN CONSENT OF CINCH. ©COPYRIGHT 2010 CINCH		4250000872S	4250000872S
CAGE IDENT NO.	SIZE	SCALE	SHEET 2 OF 2
71785	B	1:250	
REV		J	