

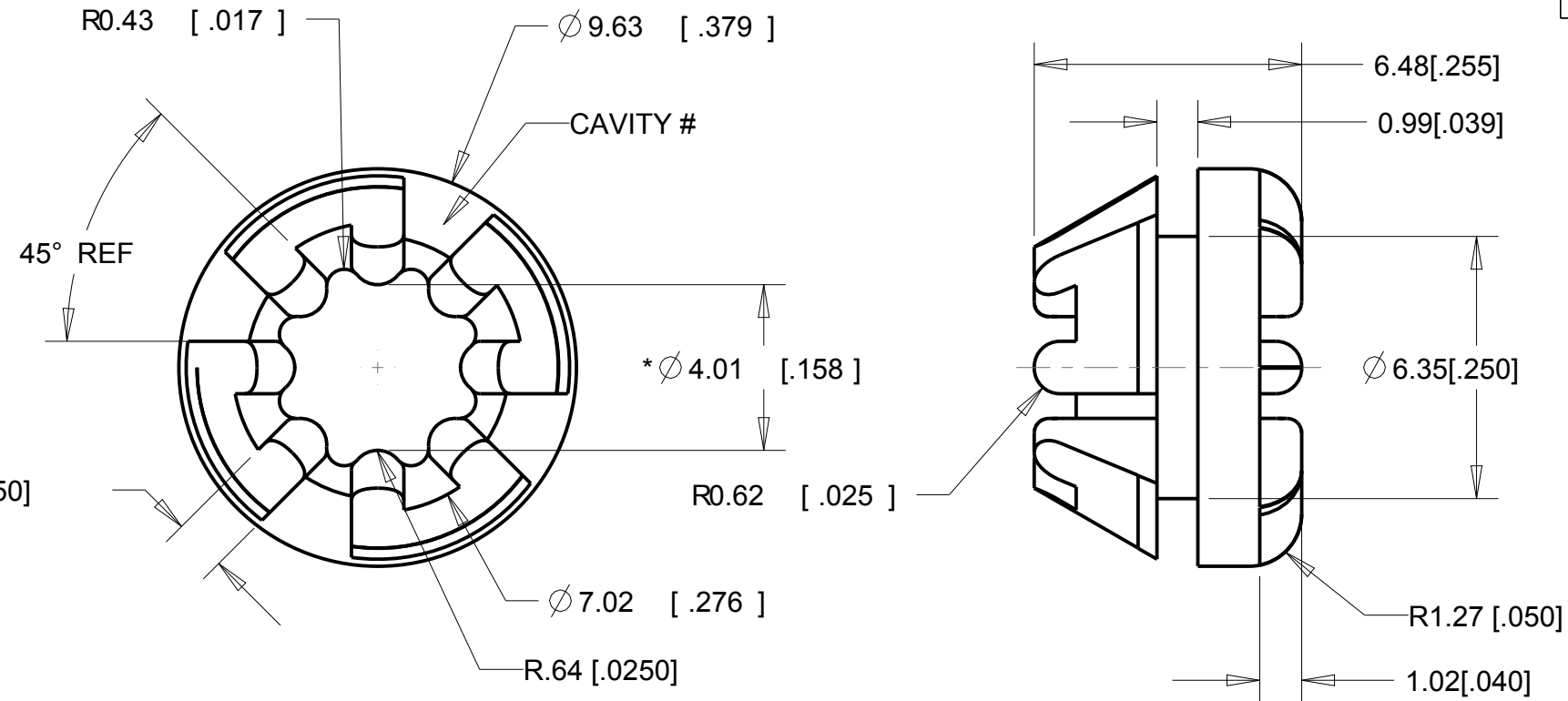

REVISIONS				
DRAWN	REV	DESCRIPTION	DATE	APPROVED
BCC	00	ORIGINAL	10-14-04	
KP	01	UPDATED FORMAT, NOTES, TOLERANCES, ADDED WEIGHT AND CAVITY LOCATION.	9-8-11	MS



PART NUMBER	MATERIAL
P-415-V2790	V-2790
P-415-V2775	V-2775
P-415-V2750	V-2750
P-415-V2590	V-2590
P-415-V2575	V-2575
P-415-V2550	V-2550
P-415-V2525	V-2525
P-415-V2375	V-2375
P-415-V2350	V-2350
P-415-V2325	V-2325
P-415-3	C-1100
P-415-2	C-1105
P-415-1	C-1002
P-415-C8002	C-8002
P-415-C8001	C-8001
P-415-C8012	C-8012

RANGE	TOL
0<DIM<=2 [0.078]	± 0.15 [.006]
2 [0.078]<DIM<=25 [0.98]	± 0.25 [.010]
25 [0.98]<DIM<=50 [1.969]	± 0.4 [.016]
50 [1.969]<DIM	± 0.6 [.024]

4. \* = MAJOR DIMESION  
 3. MAX DRAFT: 2°  
 2. CRITICAL DIMENSIONS SHALL HAVE Cpk VALUE >= 1.33 WITH ONGOING SPC DATA REQUIRED  
 1. CRITICAL DIMENSIONS ARE MARKED WITH "\*\*\*".
- NOTES:

UNLESS OTHERWISE SPECIFIED UNITS ARE: MM [IN] TOLERANCE FOR ANGLES: $\pm 0.0^\circ$	MATERIAL: <b>SEE TABLE</b>	AEARO TECHNOLOGIES LLC * a 3M company		
	ALLOWABLE FLASH: .12MM [.005]	QUALITY CONTROL: MUST COMPLY WITH E-A-R SPECIALTY COMPOSITES SUPPLIER QUALITY MANUAL REQUIREMENTS	TITLE <b>GROMMET - SYMMETRIC, INTERNALLY RIBBED</b>	
GATE: $\pm 0.25$ MM [.010]	NOTES: ANY FEATURE NOT DIMENSIONED IN PRINT MUST BE VISIBLY PRESENT, UTILIZE 3D CAD FOR CREATION	SIZE <b>B</b>	DRAWING NO. P-415-X	PAGE NO. 1 OF 1
0.24 GRAM REF				

1

2

3

4

D

D

C

C

B

B

A

A