

**Extractor Tool**

**Application Tooling  
Specification Sheet**

**Order No. 63813-1500**

**SCOPE:**

The 63813-1500 Extraction Tool is used on several different connector series. See below.

**Product List**

Products:

Terminal Series No	Description	Terminal Order Number					
19417	MX150L™ Male Terminals, 14-22 AWG	19417-0011	19417-0024	19417-0025	19417-0026	19417-0027	19417-0028
		19417-0029	19417-0030	19417-0031	19417-0032	19417-0033	19417-0034
		19417-0047	19417-0048	19417-0049	19417-0050	19417-0051	19417-0052
		19417-0053	19417-0054				
19420	MX150L™ Female Terminals, 14-22 AWG	19420-0001	19420-0002	19420-0003	19420-0004	19420-0007	19420-0008
		19420-0009	19420-0010	19420-0011	19420-0012		
31296	MX150™ Male Terminals, 14-22 AWG	31296-0004	31296-0008	31296-1004	31296-1008		
33000	MX150™ Male Terminals, 14-22 AWG	33000-0001	33000-0002	33000-0003	33000-0004	33000-1001	33000-1002
		33000-1003	33000-1004				
33001	MX150™ Female Terminals, 14-22 AWG	33001-2003	33001-2004	33001-2005	33001-2006	33001-2021	33001-2022
		33001-2023	33001-3003	33001-3004	33001-3005	33001-3006	33001-3021
		33001-3022	33001-3023	33001-4001	33001-4002	33001-4003	33001-4005
		33001-4021	33001-4022	33001-4023	33001-5001	33001-5002	33001-5003
		33001-5005	33001-5021	33001-5022	33001-5023		
33011	MX150™ Male Terminals, 14-22 AWG	33011-0002	33011-0004	33011-0006	33011-0008	33011-1002	33011-1004
		33011-1006	33011-1008	33011-2001	33011-2002	33011-2003	33011-2004
		33011-3001	33011-3002	33011-3003	33011-3004		
33012	MX150™ Female Terminals, 14-22 AWG	33012-2001	33012-2002	33012-2003	33012-2004	33012-2021	33012-2022
		33012-2023	33012-3001	33012-3002	33012-3003	33012-3004	33012-3021
		33012-3022	33012-3023				
34750	MX150™ Male Terminals, 14-22 AWG	34750-0001	34750-0002	34750-0003	34750-0004	34750-1001	34750-1002
		34750-1003	34750-1004				
34081	MX150™ Female Terminals, 14-22 AWG	34081-2003	34081-2004	34081-2005	34081-3003	34081-3004	34081-3005
		34081-4001	34081-4002	34081-4003	34081-5001	34081-5002	34081-5003
34083	MX150™ Female Terminals, 14-22 AWG	34083-2001	34083-2002	34083-2003	34083-3001	34083-3002	34083-3003
34780	MX150™ Female Terminals, 14-22 AWG	34780-0001	34780-0002	34780-0003	34780-0004	34780-1001	34780-1002
		34780-1003	34780-1004				
34781	MX150™ Male Terminals, 14-22 AWG	34781-0004	34781-1004				
34782	MX150™ Male Terminals, 14-22 AWG	34782-0001	34782-0002	34782-0003	34782-1001	34782-1002	34782-1003

Terminal Series No	Description	Terminal Order Number					
35464	PT Bulb Socket, AVSS 0.50~0.85mm <sup>2</sup>	35464-8000					
501647	2.00mm (.079") Pitch iGrid™ Wire-to-Board, Female, 22-26 AWG	501647-1000	501647-1100				
501648	2.00mm (.079") Pitch iGrid™ Wire-to-Board, Female, 22-28 AWG	501648-1000	501648-1100				
5103	SPOX™ Crimp Terminal 22-28 AWG	08-70-0056	08-70-0057	08-70-0058	08-70-0059	39-00-0188	39-00-0189
		39-00-0387	39-00-0388	39-00-0389	39-00-0390	39-00-0442	87-00-0569
		87-00-0589					
59323	Wire to Motor connector Terminal	59323-8000	59323-8100	59323-8200	59323-8300		

The above chart is a partial list of the product order numbers and their specifications this tool is designed to run. Updates to this list are available on [www.molex.com](http://www.molex.com).

**DESCRIPTION:**

Extraction Tool is used on extract terminals from several different connector series.

It is 67.6mm (2.66 in.) long by 6.35mm (.25 in.) diameter, and weight about 0.03kg (1 oz.). See Figure 1.

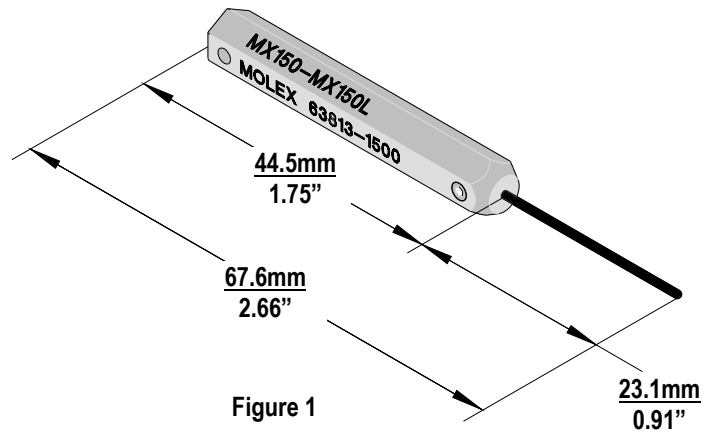

**OPERATION:**

For 19417, 19420, 33001, 33012, 34750, 34780, 34081, and 34083 Terminal Series:

2. Release the terminal from the connector assembly.
  - Insert and drive forward (0.9 to 1.0mm) diameter the service tool to release terminal.
  - Pull the terminal from the rear of the connector.

**SEALED RECEPTACLE ASSEMBLY-SERVICEABILITY**

1. Return the TPA to the pre-lock position.
  - Use the Standard Screwdriver to return the TPA to pre-lock.
  - Listen for the loud audible "click".

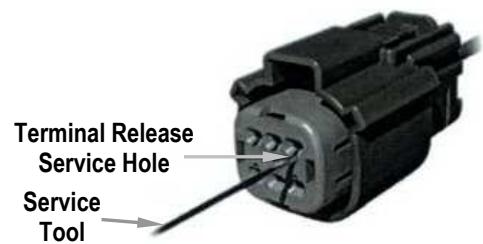
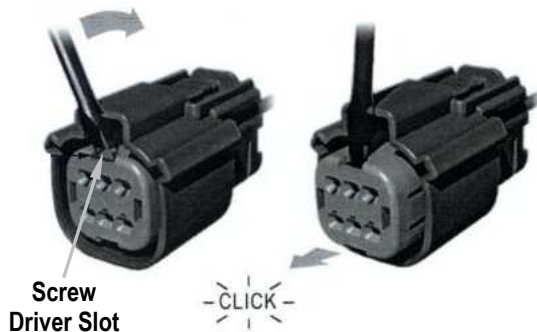

For 31296, 33000, 33011, 34781, and 34782 Series:

**SEALED BLADE ASSEMBLY-SERVICEABILITY**

1. Return the TPA to the pre-lock position
  - Use the Standard Needle Nose Pliers to return the TPA to pre-lock.
  - Listen for the loud audible "click".

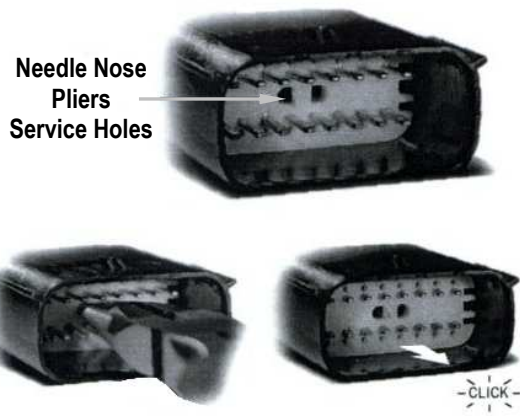

- Insert and drive forward (0.9 to 1.0mm) diameter the service tool to release terminal.
- Pull the terminal from the rear of the connector.

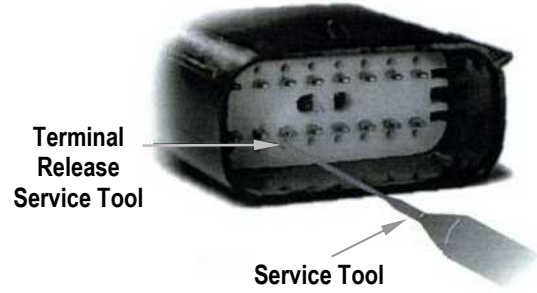

2 Release the terminal from the connector assembly.

**TERMINAL INSTALLATION**

**Terminal Orientation Feature**

This is the Terminal orientation at the matte seal grommet cap.



**OPERATION:**

**For 501647, 501648, and 5103 Terminal Series:**

Individual terminals may be extracted from the housing using this Tool.

1. Push the terminal and the wire forward in the arrow direction before using this Tool. Insert the Tool into the slot above the locking tang of the terminal. Push the tool down until the locking tang is even with the rest of the terminal. This will free the terminal from the housing.
2. Holding the wire and the tool together, pull the wire back through the connector slot in the arrow direction as shown in Figure 2.

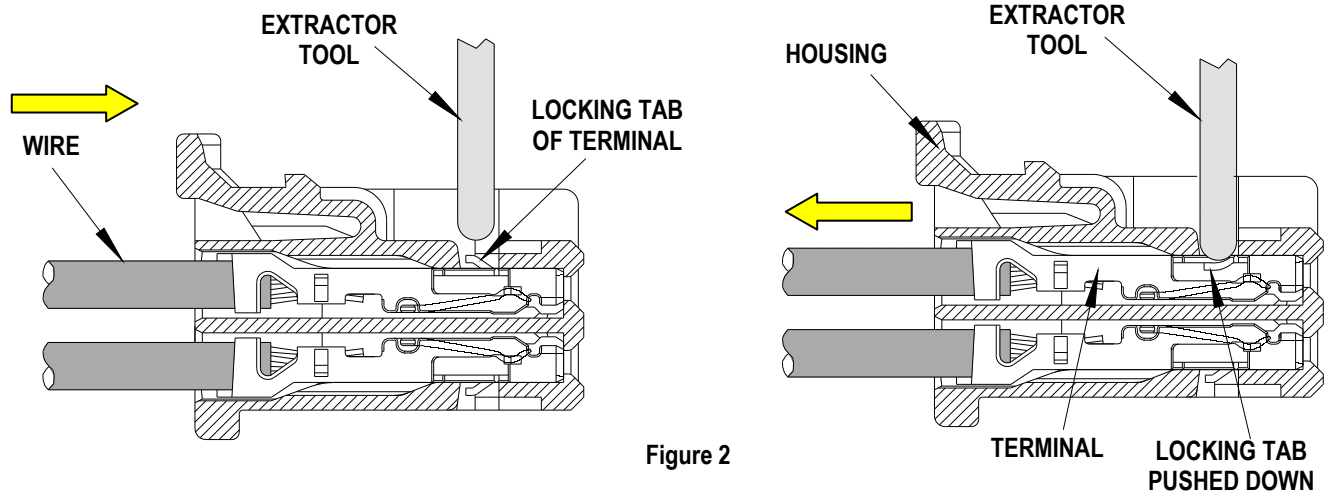

Figure 2

**For 59323 Terminal Series:**

Individual terminals may be extracted from the housing using this Tool.

1. Insert the tip of the Extractor Tool into the end of the pocket of the housing. Push the tool down until it stops.

Figure 3

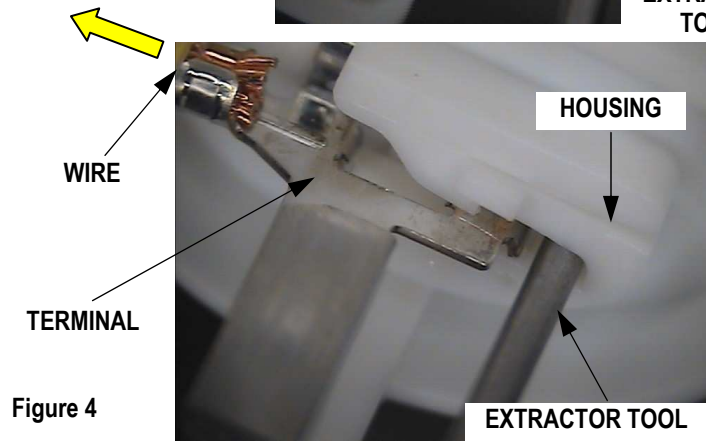
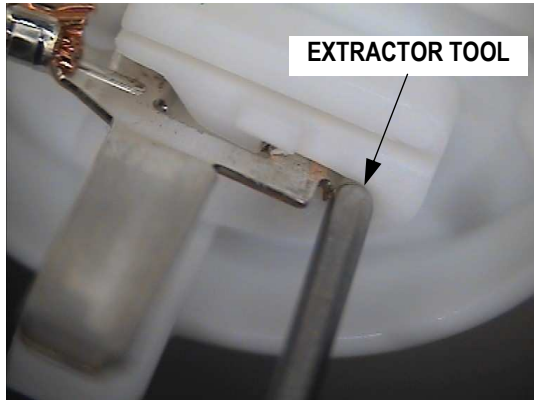
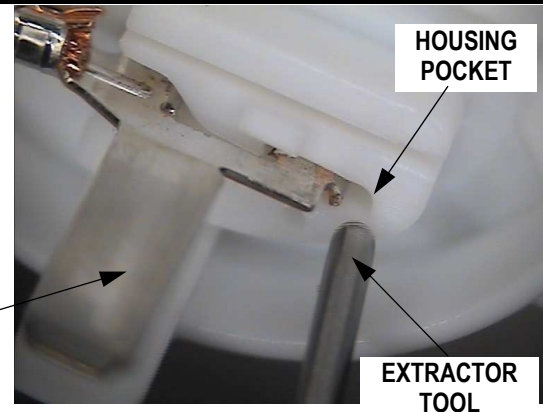

Figure 4

2. The Latch on the housing will open and then release the terminal. Pull the crimped terminal out by the wire in the direction shown. See Figure 3 and 4.

**For 34564 Terminal Series:**

1. Push the terminal and wire forward in the arrow direction before using the Extractor Tool.
2. Insert the tip of the Extractor tool below the seal and terminal into the hole of the connector housing.
3. Gently push the tool under the terminal until the wings of the terminal lift up and out of the slot.
4. Using an eraser end of a pencil push down on the top of the terminal.
5. Pull the terminal and wire out of the hole. See Figure 5.

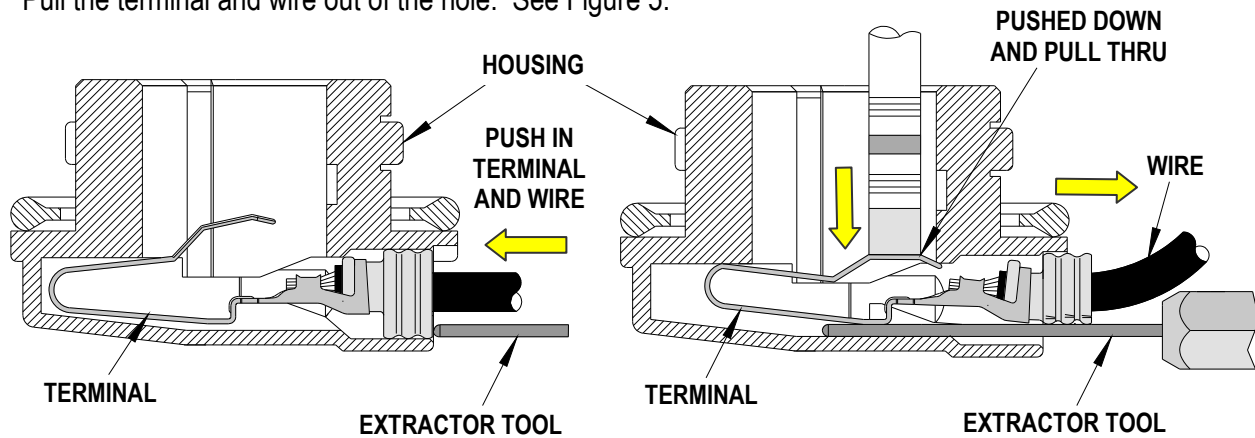

Figure 5

Molex does not offer repair parts for this tool due to the inexpensive nature of the tool.

<http://www.molex.com>