

ASSEMBLY NUMBER	DETAILS			G MAX	L MAX	BB DIA +.000 -.010	CC DIA	Y THREAD		W +.000 -.010	SCREW SIZE
	NUT	CLAMP						SIZE-CLASS 2B	PITCH DIA		
		PART NUMBER	QTY								
10-101987-8	10-101970-8	10-130511-8	2	.775	1.190	.250	.540	.4375-28UNEF	.4143-.4189	.215	6-32NC
-10	-10	-10		.837		.312	.665	.5625-24UNEF	.5354-.5405		
-12	-12	-12		.963		.438	.793	.6875-24UNEF	.6604-.6656		
-14	-14	-14		1.087		.562	.910	.8125-20UNEF	.7800-.7857		
-16	-16	-16		1.150	1.292	.624	1.037	.9375-20UNEF	.9050-.9109		
-18	-18	-18		1.400	1.292	.750	1.155	1.0625-18UNEF	1.0264-1.0326		8-32NC
-20	-20	-18		1.400	1.332	.750	1.281	1.1875-18UNEF	1.1514-1.1577	.312	
-22	-22	-20		1.587	1.332	.938	1.408	1.3125-18UNEF	1.2764-1.2827	.312	
-24	-24	-22		1.681	1.332	1.000	1.533	1.4375-18UNEF	1.4014-1.4079	.312	

2											
3											
4											
5	42524-303										
A1	43524-505										
A2	43524-1481										
A3	43524-791										
A4	43524-765										
A5	53536-78										
B	23813										
C	84450										
D	86810										

SUPERCEDES PRIOR ISSUE  
OF THE SAME REVISION

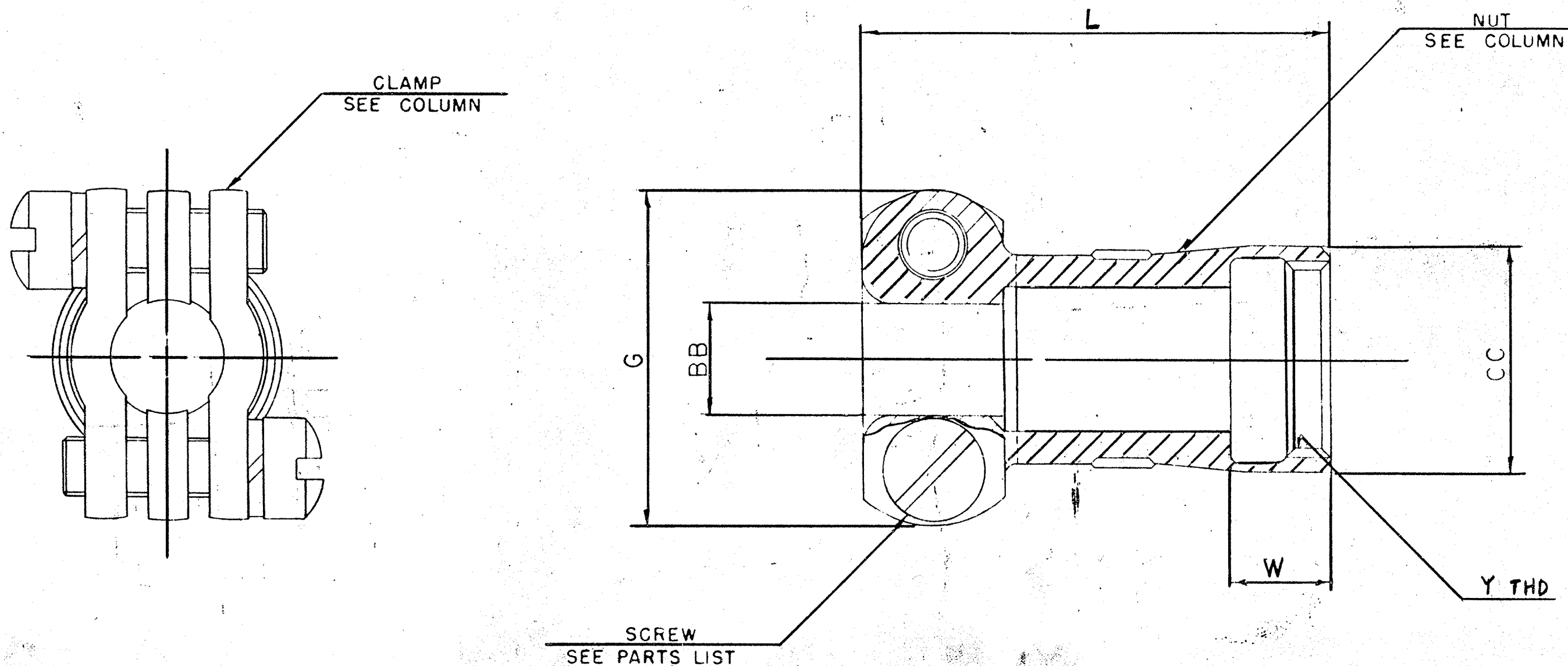

10-101987

Scanned

1. TO COMPLETE ASSEMBLY NO. AND DETAIL NO., ADD APPLICABLE LAST DIGIT SUFFIX NO FOR DESIRED FINISH:

CHROMATE TREATED	SUFFIX-XX0
BRIGHT CADMIUM PLATE	SUFFIX-XX1
BLACK ANODIZE	SUFFIX-XX2
CADMIUM PLATE OLIVE DRAB	SUFFIX-XX3
GRAY ANODIZE	SUFFIX-XX4
ANODIC COATING	SUFFIX-XX5
NICKEL PLATED	SUFFIX-XX6
CADMIUM PLATE NICKEL BASE	SUFFIX-XX7
BRIGHT NICKEL	SUFFIX-XX8
OLIVE DRAB CADMIUM NICKEL BASE PLATE	SUFFIX-XX9
CHROMIUM PLATED	SUFFIX-XXE
NICKEL ALLOY PLATE	SUFFIX-XXG

RELEASE  
42524-119  
33508-95

BLACK ZINC ALLOY CONDUCTIVE PLATE SUFFIX-XXX  
BLACK ZINC ALLOY PLATE SUFFIX-XXY

43524-558  
42524-303  
43524-1481  
53536-78

SCINTILLA MAGNETO DIVISION		TO ORDER UNLESS OTHERWISE SPECIFIED	
CLAMP ASSEMBLY, CABLE STRAIN RELIEF, ELECTRICAL CONNECTOR, TYPE PC(I)		MATERIAL SPECIFICATION	
SEE NOTE I		PART NUMBER	
		10-117600/624	
		71-150700/724	
		SEE PARTS LIST	
		10-101987	