

**SYSMAC
CPM2B**

Programmable Controller

OPERATION MANUAL

OMRON

SYSMAC CPM2B

Programmable Controller

Operation Manual

Revised July 2003

Notice:

OMRON products are manufactured for use according to proper procedures by a qualified operator and only for the purposes described in this manual.

The following conventions are used to indicate and classify precautions in this manual. Always heed the information provided with them. Failure to heed precautions can result in injury to people or damage to property.

 **DANGER** Indicates an imminently hazardous situation which, if not avoided, will result in death or serious injury.

 **WARNING** Indicates a potentially hazardous situation which, if not avoided, could result in death or serious injury.

 **Caution** Indicates a potentially hazardous situation which, if not avoided, may result in minor or moderate injury, or property damage.

OMRON Product References

All OMRON products are capitalized in this manual. The word “Unit” is also capitalized when it refers to an OMRON product, regardless of whether or not it appears in the proper name of the product.

The abbreviation “Ch,” which appears in some displays and on some OMRON products, often means “word” and is abbreviated “Wd” in documentation in this sense.

The abbreviation “PLC” means Programmable Controller. “PC” is used, however, in some Programming Device displays to mean Programmable Controller.

Visual Aids

The following headings appear in the left column of the manual to help you locate different types of information.

Note Indicates information of particular interest for efficient and convenient operation of the product.

1,2,3... 1. Indicates lists of one sort or another, such as procedures, checklists, etc.

© OMRON, 2000

All rights reserved. No part of this publication may be reproduced, stored in a retrieval system, or transmitted, in any form, or by any means, mechanical, electronic, photocopying, recording, or otherwise, without the prior written permission of OMRON.

No patent liability is assumed with respect to the use of the information contained herein. Moreover, because OMRON is constantly striving to improve its high-quality products, the information contained in this manual is subject to change without notice. Every precaution has been taken in the preparation of this manual. Nevertheless, OMRON assumes no responsibility for errors or omissions. Neither is any liability assumed for damages resulting from the use of the information contained in this publication.

TABLE OF CONTENTS

PRECAUTIONS	xi
1 Intended Audience	xii
2 General Precautions	xii
3 Safety Precautions	xii
4 Operating Environment Precautions	xiv
5 Application Precautions	xiv
6 EC Directives	xvi
SECTION 1	
Introduction	1
1-1 CPM2B Features and Functions	2
1-2 System Configurations	8
1-3 Structure and Operation	15
SECTION 2	
Board Specifications and Components	23
2-1 Specifications	24
2-2 Board Components and their Functions	34
2-3 I/O Connector and Terminal Pin Allocation	40
SECTION 3	
Installation and Wiring	45
3-1 Design Precautions	46
3-2 Selecting an Installation Site	47
3-3 Assembling the CPM2B Boards	48
3-4 Installing the CPM2B	51
3-5 Wiring and Connections	51
SECTION 4	
Memory Areas	69
4-1 Introduction	70
4-2 I/O Allocation	72
4-3 SR Area	76
4-4 AR Area	79
4-5 PLC Setup	82
4-6 Error Log	88
SECTION 5	
Instruction Set	89
5-1 CPM2B Function Codes	90
5-2 Alphabetic List by Mnemonic	91
5-3 Expansion Instructions	94

TABLE OF CONTENTS

SECTION 6

Using Analog I/O Boards	95
6-1 Overview of Analog I/O Boards	96
6-2 Specifications and Part Names	97
6-3 Overview of Operations	103
6-4 Application Procedure	105
6-5 Troubleshooting Unit Errors	116

SECTION 7

Using Programming Devices	119
7-1 Using a Programming Console	120
7-2 Programming Console Operations	127
7-3 Programming Example	153

SECTION 8

Test Runs and Error Processing	161
8-1 Initial System Checks and Test Run Procedure	162
8-2 CPM2B Test Run Procedure	163
8-3 Self-diagnostic Functions	163
8-4 Troubleshooting Flowcharts	166
8-5 Maintenance Inspections	174
8-6 Battery Replacement	175

Appendices

A Standard Models	177
B Dimensions	181
C Connections Diagrams for Connector Terminal Blocks and Relay Terminals	185

Index	193
--------------------	------------

Revision History	199
-------------------------------	------------

About this Manual:

This manual describes the installation and operation of the CPM2B and includes the sections described below.

The CPM2B is a compact, high-speed board Programmable Controller (PLC) designed for control operations. There are two manuals describing the setup and operation of the CPM2B: The *CPM2B Operation Manual* (this manual) and the *CPM1/CPM1A/CPM2A/CPM2C/SRM1(-V2) Programming Manual* (W353). (The *CPM1/CPM1A/CPM2A/CPM2C/SRM1(-V2) Programming Manual* is referred to as simply the *Programming Manual* in this manual.)

This manual describes the system configuration and installation of the CPM2B and provides a basic explanation of operating procedures for the Programming Consoles. Read this manual first to acquaint yourself with the CPM2B.

The *Programming Manual* (W353) provides detailed descriptions of the CPM2B's programming functions. The *WS02-CXP□□-E CX-Programmer Operation Manual* (W414) provides details of operations for the WS02-CXP□□-E CX-Programmer.

Please read this manual carefully and be sure you understand the information provided before attempting to install and operate the CP2MB.

Section 1 describes the CPM2B's special features and functions, shows the possible system configurations, and outlines the steps required before operation. Read this section first when using the CPM2B for the first time. Refer to the *CPM1/CPM1A/CPM2A/CPM2C/SRM1(-V2) Programming Manual* (W353) for details on programming.

Section 2 provides the technical specifications of the CPM2B Boards and describes the main components of the Boards.

Section 3 provides information on installing and wiring a CPM2B PLC. Be sure to follow the directions and precautions in this section when installing the CPM2B in a panel or cabinet, wiring the power supply, or wiring I/O.

Section 4 describes the structure of the PLC memory areas and explains how to use them.

Section 5 provides a brief summary of the instruction set. Refer to the *CPM1/CPM1A/CPM2A/CPM2C/SRM1(-V2) Programming Manual* (W353) for details on specific instructions.

Section 6 provides an overview of Analog I/O Boards, including specifications, wiring, installation methods, basic settings, operations, and information on creating ladder programs.

Section 7 provides information on Programming Console operations.

Section 8 describes procedures for trial CPM2B operation, self-diagnosis functions, and error processing to identify and correct the hardware and software errors that can occur during PLC operation.

Appendices provides lists of standard models and Board dimensions.

 **WARNING** Failure to read and understand the information provided in this manual may result in personal injury or death, damage to the product, or product failure. Please read each section in its entirety and be sure you understand the information provided in the section and related sections before attempting any of the procedures or operations given.

PRECAUTIONS

This section provides general precautions for using the Programmable Controller (PLC) and related devices.

The information contained in this section is important for the safe and reliable application of the Programmable Controller. You must read this section and understand the information contained before attempting to set up or operate a PLC system.

1	Intended Audience	xii
2	General Precautions	xii
3	Safety Precautions	xii
4	Operating Environment Precautions	xiv
5	Application Precautions	xiv
6	EC Directives	xvi

1 Intended Audience

This manual is intended for the following personnel, who must also have knowledge of electrical systems (an electrical engineer or the equivalent).

- Personnel in charge of installing FA systems.
- Personnel in charge of designing FA systems.
- Personnel in charge of managing FA systems and facilities.

2 General Precautions

The user must operate the product according to the performance specifications described in the operation manuals.

Before using the product under conditions which are not described in the manual or applying the product to nuclear control systems, railroad systems, aviation systems, vehicles, combustion systems, medical equipment, amusement machines, safety equipment, and other systems, machines, and equipment that may have a serious influence on lives and property if used improperly, consult your OMRON representative.

Make sure that the ratings and performance characteristics of the product are sufficient for the systems, machines, and equipment, and be sure to provide the systems, machines, and equipment with double safety mechanisms.

This manual provides information for programming and operating the Unit. Be sure to read this manual before attempting to use the Unit and keep this manual close at hand for reference during operation.

 **WARNING** It is extremely important that a PLC and all PLC Units be used for the specified purpose and under the specified conditions, especially in applications that can directly or indirectly affect human life. You must consult with your OMRON representative before applying a PLC System to the above-mentioned applications.

3 Safety Precautions

 **WARNING** Do not attempt to take any board apart while the power is being supplied. Doing so may result in electric shock.

 **WARNING** Do not touch any of the terminals, terminal blocks or, for the CPM2B, the CPU board or expansion I/O board while the power is being supplied. Doing so may result in electric shock.

 **WARNING** When handling the Memory Backup Battery, never drop, disassemble, distort, short-circuit, heat to a high temperature, or throw into fire. Otherwise the Battery may explode, catch fire, or leak fluid.

 **WARNING** Do not attempt to disassemble, repair, or modify any Units. Any attempt to do so may result in malfunction, fire, or electric shock.

⚠ WARNING Provide safety measures in external circuits (i.e., not in the Programmable Controller), including the following items, in order to ensure safety in the system if an abnormality occurs due to malfunction of the PLC or another external factor affecting the PLC operation. Not doing so may result in serious accidents.

- Emergency stop circuits, interlock circuits, limit circuits, and similar safety measures must be provided in external control circuits.
- The PLC will turn OFF all outputs when its self-diagnosis function detects any error or when a severe failure alarm (FALS) instruction is executed. As a countermeasure for such errors, external safety measures must be provided to ensure safety in the system.
- The PLC outputs may remain ON or OFF due to deposition or burning of the output relays or destruction of the output transistors. As a countermeasure for such problems, external safety measures must be provided to ensure safety in the system.

⚠ WARNING When transferring programs to other nodes, or when making changes to I/O memory, confirm the safety of the destination node before transfer. Not doing so may result in injury.

⚠ Caution Execute online edit only after confirming that no adverse effects will be caused by extending the cycle time. Otherwise, the input signals may not be readable.

⚠ Caution Tighten the screws on the terminal block to the torque specified in the operation manual. The loose screws may result in burning or malfunction.

⚠ Caution When connecting the PLC to a personal computer or other peripheral device, either ground the 0-V side of the PLC or do not ground the PLC at all. Although some grounding methods short the 24-V side, as shown in the following diagram, never do so with the PLC.

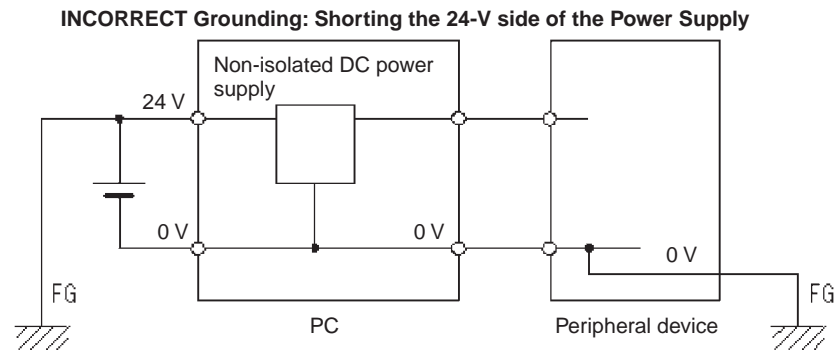

4 Operating Environment Precautions

 **Caution** Do not operate the control system in the following places:

- Locations subject to direct sunlight.
- Locations subject to temperatures or humidity outside the range specified in the specifications.
- Locations subject to condensation as the result of severe changes in temperature.
- Locations subject to corrosive or flammable gases.
- Locations subject to dust (especially iron dust) or salts.
- Locations subject to exposure to water, oil, or chemicals.
- Locations subject to shock or vibration.

 **Caution** Take appropriate and sufficient countermeasures when installing systems in the following locations:

- Locations subject to static electricity or other forms of noise.
- Locations subject to strong electromagnetic fields.
- Locations subject to possible exposure to radioactivity.
- Locations close to power supplies.

 **Caution** The operating environment of the PLC System can have a large effect on the longevity and reliability of the system. Improper operating environments can lead to malfunction, failure, and other unforeseeable problems with the PLC System. Be sure that the operating environment is within the specified conditions at installation and remains within the specified conditions during the life of the system.

5 Application Precautions

Observe the following precautions when using the PLC System.

 **WARNING** Always heed these precautions. Failure to abide by the following precautions could lead to serious or possibly fatal injury.

- Always turn OFF the power supply to the PLC before attempting any of the following. Not turning OFF the power supply may result in malfunction or electric shock.
 - Mounting or dismounting the CPU board or expansion I/O board.
 - Setting switches or rotary switches.
 - Connecting or wiring the cables.
 - Connecting or disconnecting the connectors.

 **Caution** Failure to abide by the following precautions could lead to faulty operation of the PLC or the system, or could damage the PLC. Always heed these precautions.

- Fail-safe measures must be taken by the customer to ensure safety in the event of incorrect, missing, or abnormal signals caused by broken signal lines, momentary power interruptions, or other causes.
- Construct a control circuit so that power supply for the I/O circuits does not come ON before power supply for the PLC. If power supply for the I/O circuits comes ON before power supply for the PLC, normal operation may be temporarily interrupted.
- If the operating mode is changed from RUN or MONITOR mode to PROGRAM mode, with the IOM Hold Bit ON, the output will hold the most recent status. In such a case, ensure that the external load does not exceed specifications. (If operation is stopped because of an operation error (including FALS instructions), the values in the internal memory of the CPU board will be saved, but the outputs will all turn OFF.)
- Always use the power supply voltage specified in the operation manuals. An incorrect voltage may result in malfunction or burning.
- Take appropriate measures to ensure that the specified power with the rated voltage is supplied. Be particularly careful in places where the power supply is unstable. An incorrect power supply may result in malfunction.
- Install external breakers and take other safety measures against short-circuiting in external wiring. Insufficient safety measures against short-circuiting may result in burning.
- Do not apply voltages to the input terminals in excess of the rated input voltage. Excess voltages may result in burning.
- Do not apply voltages or connect loads to the output terminals in excess of the maximum switching capacity. Excess voltage or loads may result in burning.
- Be sure that all the mounting screws, terminal screws, and cable connector screws are tightened to the torque specified in the relevant manuals. Incorrect tightening torque may result in malfunction.
- When wiring the CPM2B, take countermeasures to prevent wiring cuttings from coming into contact with the product, such as covering the whole product with a dustproof cover. If wiring cuttings adhere to the PCB or circuit elements they may cause short-circuiting.
- Be sure to perform wiring in accordance with the relevant operation manual. Incorrect wiring may result in burning.
- Double-check all the wiring before turning ON the power supply. Incorrect wiring may result in burning.
- Be sure that the terminal blocks, expansion cables, and other items with locking devices are properly locked into place. Improper locking may result in malfunction.
- Be sure that terminal blocks and connectors are connected in the specified direction with the correct polarity. Not doing so may result in malfunction.
- Check the user program for proper execution before actually running it on the PLC. Not checking the program may result in an unexpected operation.
- Confirm that no adverse effect will occur in the system before attempting any of the following. Not doing so may result in an unexpected operation.
 - Changing the operating mode of the PLC.
 - Force-setting/force-resetting any bit in memory.

- Changing the present value of any word or any set value in memory.
- Resume operation only after transferring to the new CPU board the contents of the DM and HR Areas required for resuming operation. Not doing so may result in an unexpected operation.
- Do not pull on the cables or bend the cables beyond their natural limit. Doing either of these may break the cables.
- Do not place objects on top of the cables. Doing so may break the cables.
- Under no circumstances should batteries be short-circuited between positive (+) and negative (–) terminals, charged, disassembled, heated, or thrown into fire.
- When replacing parts, be sure to confirm that the rating of a new part is correct. Not doing so may result in malfunction or burning.
- When transporting or storing the CPM2B, cover the circuit boards in anti-static material to protect them from static electricity and maintain the proper storage temperature.
- Before touching the Unit, be sure to first touch a grounded metallic object in order to discharge any static build-up. Not doing so may result in malfunction or damage.
- Do not touch the expansion I/O connecting cable while the power is being supplied in order to prevent any malfunction due to static electricity.
- Do not touch CPM2B circuit boards or the components mounted to them with your bare hands. There are sharp leads and other parts on the boards that may cause injury if handled improperly.
- When disposing the product, observe local ordinances and regulations.

6 EC Directives

6-1 Applicable Directives

- EMC Directives
- Low Voltage Directive

6-2 Concepts

EMC Directives

OMRON devices that comply with EC Directives also conform to the related EMC standards so that they can be more easily built into other devices or the overall machine. The actual products have been checked for conformity to EMC standards (see the following note). Whether the products conform to the standards in the system used by the customer, however, must be checked by the customer.

EMC-related performance of the OMRON devices that comply with EC Directives will vary depending on the configuration, wiring, and other conditions of the equipment or control panel on which the OMRON devices are installed. The customer must, therefore, perform the final check to confirm that devices and the overall machine conform to EMC standards.

Note Applicable EMC (Electromagnetic Compatibility) standards are as follows:

EMS (Electromagnetic Susceptibility): EN61131-2
EMI (Electromagnetic Interference): EN50081-2
(Radiated emission: 10-m regulations)

Low Voltage Directive

Always ensure that devices operating at voltages of 50 to 1,000 V AC and 75 to 1,500 V DC meet the required safety standards for the PLC (EN61131-2).

6-3 Conformance to EC Directives

The CPM2B PLCs comply with EC Directives. To ensure that the machine or device in which the CPM2B PLC is used complies with EC directives, the PLC must be installed as follows:

- 1,2,3...
1. The CPM2B PLC must be installed within a control panel.
 2. Reinforced insulation or double insulation must be used for the DC power supplies used for the communications and I/O power supplies.
 3. CPM2B PLCs complying with EC Directives also conform to the Common Emission Standard (EN50081-2). Radiated emission characteristics (10-m regulations) may vary depending on the configuration of the control panel used, other devices connected to the control panel, wiring, and other conditions. You must therefore confirm that the overall machine or equipment complies with EC Directives.

6-4 Relay Output Noise Reduction Methods

The CPM2B PLCs conform to the Common Emission Standards (EN50081-2) of the EMC Directives. However, the noise generated when the PLC is switched ON or OFF using the relay output may not satisfy these standards. In such a case, a noise filter must be connected to the load side or other appropriate countermeasures must be provided external to the PLC.

Countermeasures taken to satisfy the standards vary depending on the devices on the load side, wiring, configuration of machines, etc. Following are examples of countermeasures for reducing the generated noise.

Countermeasures

(Refer to EN50081-2 for more details.)

Countermeasures are not required if the frequency of load switching for the whole system with the PLC included is less than 5 times per minute.

Countermeasures are required if the frequency of load switching for the whole system with the PLC included is 5 times or more per minute.

Countermeasure Examples

When switching an inductive load, connect a surge protector, diodes, etc., in parallel with the load or contact as shown below.

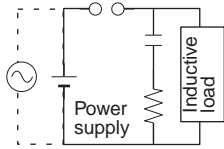
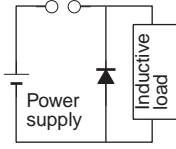
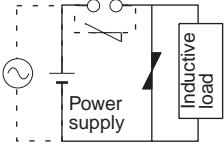
Circuit	Current		Characteristic	Required element
	AC	DC		
<p>CR method</p> 	Yes	Yes	<p>If the load is a relay or solenoid, there is a time lag between the moment the circuit is opened and the moment the load is reset.</p> <p>If the supply voltage is 24 to 48 V, insert the surge protector in parallel with the load. If the supply voltage is 100 to 200 V, insert the surge protector between the contacts.</p>	<p>The capacitance of the capacitor must be 1 to 0.5 μF per contact current of 1 A and resistance of the resistor must be 0.5 to 1 Ω per contact voltage of 1 V. These values, however, vary with the load and the characteristics of the relay. Decide these values from experiments, and take into consideration that the capacitance suppresses spark discharge when the contacts are separated and the resistance limits the current that flows into the load when the circuit is closed again.</p> <p>The dielectric strength of the capacitor must be 200 to 300 V. If the circuit is an AC circuit, use a capacitor with no polarity.</p>
<p>Diode method</p> 	No	Yes	<p>The diode connected in parallel with the load changes energy accumulated by the coil into a current, which then flows into the coil so that the current will be converted into Joule heat by the resistance of the inductive load.</p> <p>This time lag, between the moment the circuit is opened and the moment the load is reset, caused by this method is longer than that caused by the CR method.</p>	<p>The reversed dielectric strength value of the diode must be at least 10 times as large as the circuit voltage value. The forward current of the diode must be the same as or larger than the load current.</p> <p>The reversed dielectric strength value of the diode may be two to three times larger than the supply voltage if the surge protector is applied to electronic circuits with low circuit voltages.</p>
<p>Varistor method</p> 	Yes	Yes	<p>The varistor method prevents the imposition of high voltage between the contacts by using the constant voltage characteristic of the varistor. There is time lag between the moment the circuit is opened and the moment the load is reset.</p> <p>If the supply voltage is 24 to 48 V, insert the varistor in parallel with the load. If the supply voltage is 100 to 200 V, insert the varistor between the contacts.</p>	---

SECTION 1

Introduction

This section describes the CPM2B's special features and functions, shows the possible system configurations, and outlines the steps required before operation. Read this section first when using the CPM2B for the first time.

Refer to the *CPM1/CPM1A/CPM2A/CPM2C/SRM1(-V2) Programming Manual (W353)* for details on programming.

1-1	CPM2B Features and Functions	2
1-1-1	CPM2B Features	2
1-1-2	Overview of CPM2B Functions	7
1-2	System Configurations	8
1-2-1	CPU Boards	8
1-2-2	Expansion I/O Boards	9
1-2-3	Analog I/O Boards	10
1-2-4	Connecting a Programming Console	11
1-2-5	Support Software	11
1-2-6	One-to-one Computer Connections	12
1-2-7	One-to-N Computer Connections	13
1-2-8	OMRON PT Connections	14
1-2-9	One-to-one PLC Link Connections	15
1-3	Structure and Operation	15
1-3-1	CPU Board Structure	15
1-3-2	Operating Modes	16
1-3-3	Operating Mode at Startup	17
1-3-4	PLC Operation at Startup	17
1-3-5	Cyclic Operation and Interrupts	19

1-1 CPM2B Features and Functions

1-1-1 CPM2B Features

The CPM2B PLCs are compact Board PLCs that can be incorporated easily into control equipment. The PLCs are equipped with a variety of advanced features including synchronized pulse control, interrupt inputs, high-speed counters, pulse outputs, and a clock function.

- The compact Board design is ideal for incorporation into control equipment.
- The CPU Board itself can handle a wide range of machine control applications, so it is ideal for use as a built-in control unit in control equipment.
- The CPM2B is equipped with a full complement of communications functions to provide communications with personal computers, other OMRON PLCs, and OMRON Programmable Terminals. These communications capabilities allow the user to design a low-cost distributed production system.

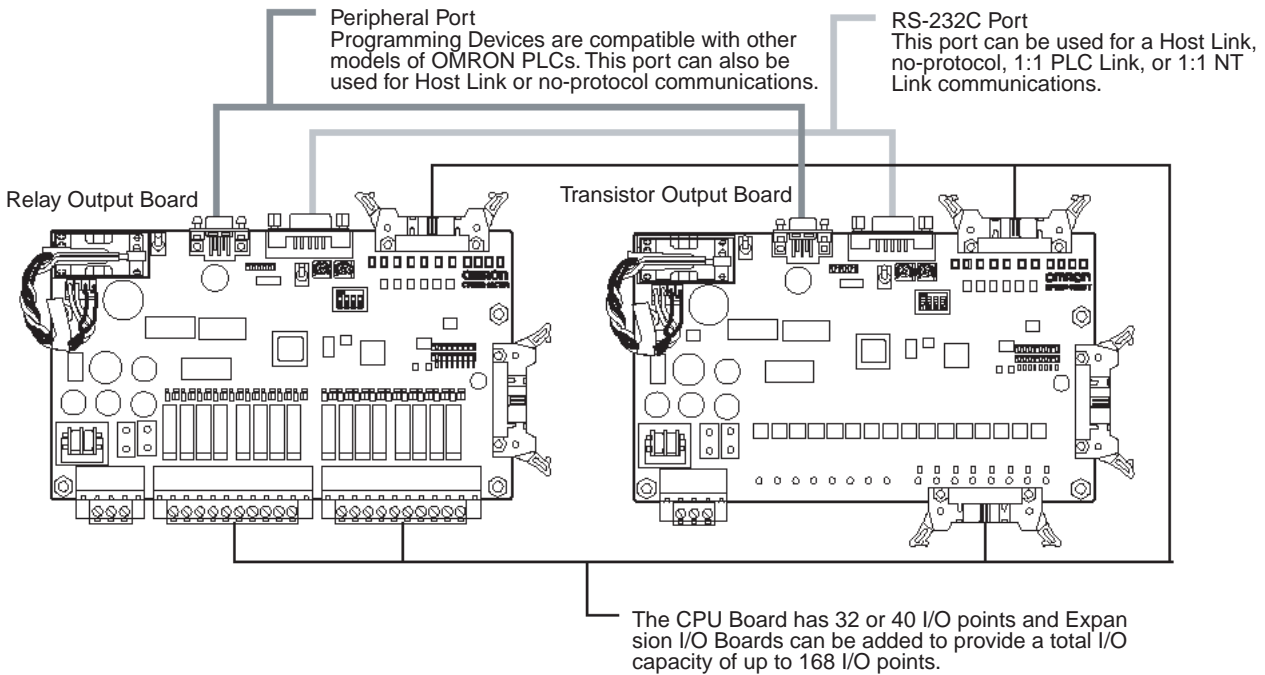

Basic Functions

CPU Board I/O

The CPM2B CPU Board itself is equipped with 32 or 40 I/O points in I/O terminals or I/O connectors. There are 2 types of outputs available (relay outputs and sinking transistor outputs). The power supply for the CPM2B CPU Board is either 12 V DC or 24 V DC only.

Expansion I/O Boards

Up to two 64-point Expansion I/O Boards can be connected to the CPU Board to increase the PLC's I/O capacity to a maximum of 168 I/O points. There are also four types of 32-point Expansion I/O Boards available: two with relay outputs and the other with sinking transistor outputs. Up to three 32-point Expansion I/O Boards can be connected to the CPU Board.

Share Programming Devices

The CX-Programmer (Ver.1.2 or later) or Programming Console can be used for programming and monitoring the CPM2B. Programming can also be performed from the SYSMAC Support Software (SSS).

Built-in Motor Control Capability

Synchronized Pulse Control (Transistor Outputs Only)

Synchronized pulse control provides an easy way to synchronize the operation of a peripheral piece of equipment with the main equipment. The output pulse frequency can be controlled as some multiple of the input pulse frequency, allowing the speed of a peripheral piece of equipment (such as a supply conveyor) to be synchronized with the speed of the main piece of equipment.

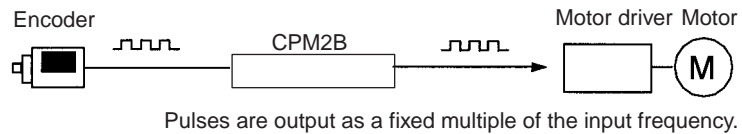

High-speed Counters and Interrupts

The CPM2B has a total of five high-speed counter inputs. The one high-speed counter input has a response frequency of 20 kHz/5 kHz and the four interrupt inputs in counter mode have a response frequency of 2 kHz.

The high-speed counter can be used in any one of the four input modes: differential phase mode (5 kHz), pulse plus direction input mode (20 kHz), up/down pulse mode (20 kHz), or increment mode (20 kHz). Interrupts can be triggered when the count matches a set value or falls within a specified range.

The interrupt inputs in counter mode can be used for incrementing counters or decrementing counters (2 kHz) and trigger an interrupt (executing the interrupt program) when the count matches the target value.

Easy Position Control with Pulse Outputs (Transistor Outputs Only)

CPM2B PLCs with transistor outputs have two outputs that can produce 10 Hz to 10 kHz pulses (single-phase outputs).

When used as single-phase pulse outputs, there can be two outputs with a frequency range of 10 Hz to 10 kHz with a fixed duty ratio or 0.1 to 999.9 Hz with a variable duty ratio (0 to 100% duty ratio).

When used as pulse plus direction or up/down pulse outputs, there can be just one output with a frequency range of 10 Hz to 10 kHz.

High-speed Input Capabilities for Machine Control

High-speed Interrupt Input Function

There are four inputs used for interrupt inputs (shared with quick-response inputs and interrupt inputs in counter mode) with a minimum input signal width of 50 μ s and response time of 0.3 ms. When an interrupt input goes ON, the main program is stopped and the interrupt program is executed.

Quick-response Input Function

There are four inputs used for quick-response inputs (shared with interrupt inputs and interrupt inputs in counter mode) that can reliably read input signals with a signal width as short as 50 μ s.

Stabilizing Input Filter Function

The input time constant for all inputs can be set to 1 ms, 2 ms, 3 ms, 5 ms, 10 ms, 20 ms, 40 ms, or 80 ms. The effects of chattering and external noise can be reduced by increasing the input time constant. (The input time constant is fixed to 1 ms for 40-point and 64-point Input Expansion I/O Board.)

Other Functions

Interval Timer Interrupts

The interval timer can be set between 0.5 and 319,968 ms and can be set to generate just one interrupt (one-shot mode) or periodic interrupts (scheduled interrupt mode).

Analog Settings

There are two controls on the CPU Board that can be turned to change the analog settings (0 to 200 BCD) in IR 250 and IR 251. These controls can be used to easily change or fine-tune machine settings such as a conveyor belt's pause time or feed rate.

DIP Switch Inputs

A DIP switch is provided that controls the status of four input bits.

Calendar/Clock

The built-in clock (accuracy within 1 minute/month) can be read from the program to show the current year, month, day, day of the week, and time. The clock can be set from a Programming Device (such as a Programming Console) or the time can be adjusted by rounding up or down to the nearest minute.

Long-term Timer

TIML(—) is a long-term timer that accommodates set values up to 99,990 seconds (27 hours, 46 minutes, 30 seconds). When combined with the SECONDS TO HOURS conversion instruction (HMS(—)), the long-term timer provides an easy way to control equipment scheduling.

Expansion Memory Unit

The CPM1-EMU01-V1 Expansion Memory Unit is a program loader for small-size or micro PLCs. Using the CPM1-EMU01-V1, simple on-site transfer of user programs and data memory is possible with PLCs.

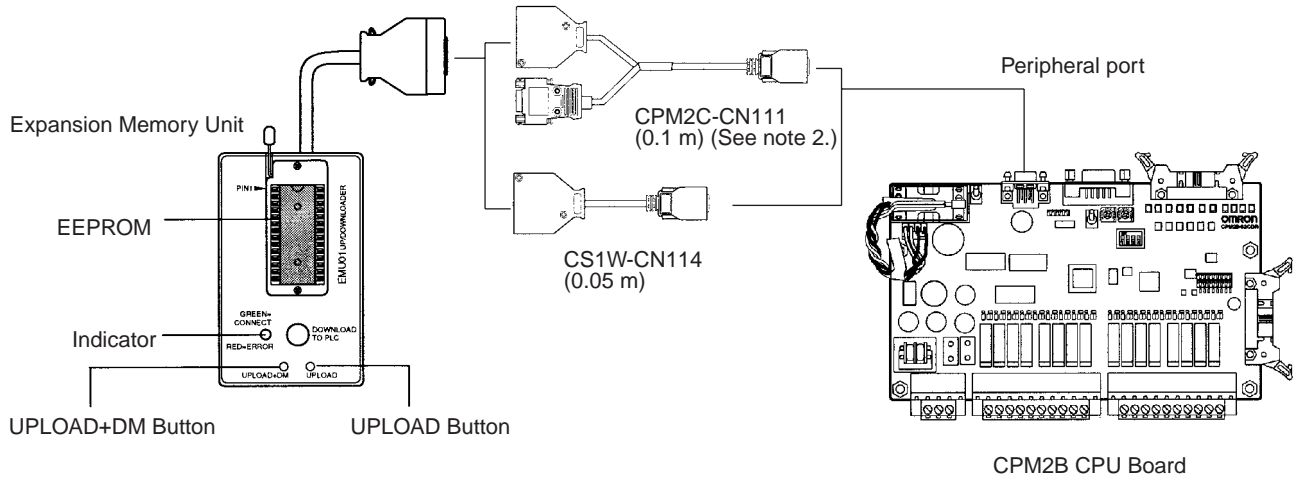

- Note**
1. Refer to the *CPM 2A Operation Manual (W352)* or *CPM2C Operation Manual* for details on the CPM1-EMU01-V1.
 2. The CPM2C-CN111 can be connected only to the peripheral port.

Capable of Analog I/O Control

A CPU Board with a 24-V DC power supply can be connected with up to three Analog I/O Boards, to which external analog I/O devices can be connected using up to eight inputs and four outputs.

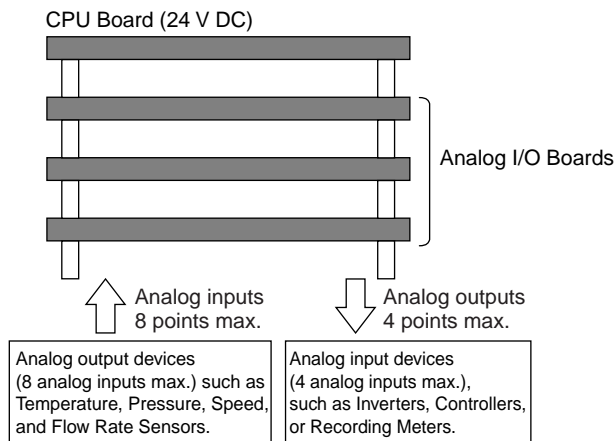

- Select the Analog I/O Boards that are appropriate for the system being used from the following three models.

Model	Number of inputs	Number of outputs	Maximum No. of connectable Units
CPM2B-MAD63	6 points	3 points	1
CPM2B-MAD42	4 points	2 points	2
CPM2B-MAD21	2 points	1 point	3

(If two CPM2B-MAD42 Analog I/O Boards are connected, there will be 8 inputs and 4 outputs.)

- Analog I/O signals correspond to various voltage/current signals, enabling connection of various analog devices.

Input signal ranges	Output signal ranges	Resolution
0 to 5 V, 1 to 5 V, 0 to 10 V, -10 to 10 V, 0 to 20 mA, and 4 to 20 mA	1 to 5 V, 0 to 10 V, -10 to 10 V, 0 to 20 mA, and 4 to 20 mA	6,000 (full scale)

- If input signals are subject to minute fluctuations, average processing can be used to read the input signals as a stable signal. Average processing can be set separately for each input using the DIP switch.
- When analog inputs are used in the range of 1 to 5 V or 4 to 20 mA, line disconnection detection will function. When the input signal level recovers, the line disconnection status is automatically cleared.

Complete Communications Capabilities

Host Link

A Host Link connection can be made through the PLC's RS-232C port or Peripheral port. A personal computer or Programmable Terminal connected in Host Link mode can be used for operations such as reading/writing data in the PLC's I/O memory or reading/changing the PLC's operating mode. (Only 1:1 connections are possible with a Programmable Terminal.)

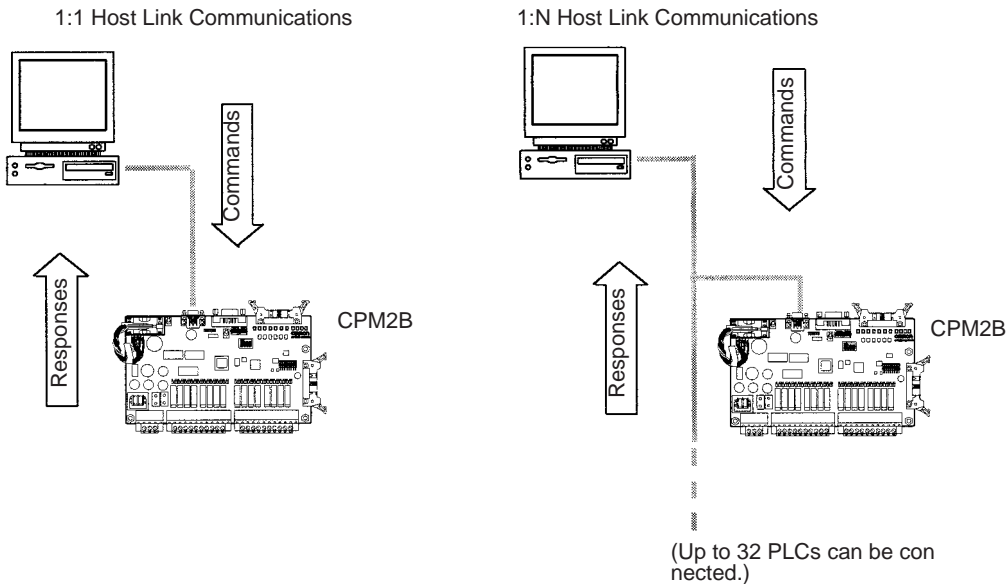

No-protocol Communications

The TXD(48) and RXD(47) instructions can be used in no-protocol mode to exchange data with standard serial devices. For example, data can be received from a bar code reader or transmitted to a serial printer. The serial devices can be connected to the RS-232C port or Peripheral port.

Inputting data from a bar code reader

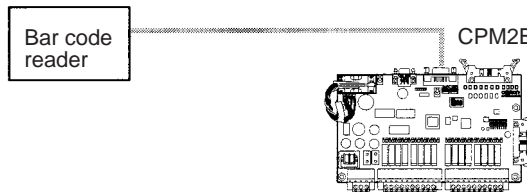

Outputting data to a serial printer

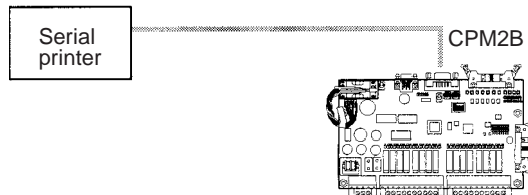

High-speed 1:1 NT Link Communications

In a 1:1 NT Link, an OMRON Programmable Terminal (PT) can be connected directly to the CPM2B. The PT must be connected to the RS-232C port; it cannot be connected to the Peripheral port.

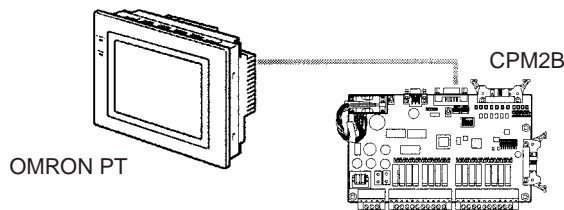

One-to-one PLC Link

A CPM2B can be linked directly to another CPM2B, CQM1, CPM1, CPM1A, CPM2A, CPM2C, SRM1(-V2), C200HS or C200HX/HG/HE PLC. The 1:1 PLC Link allows automatic data link connections. The PLCs must be connected through the RS-232C ports; they cannot be connected through the Peripheral ports.

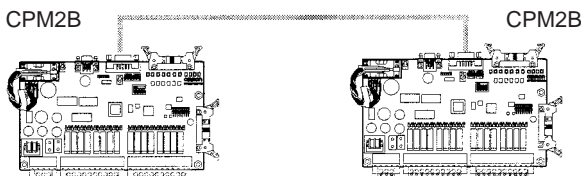

1-1-2 Overview of CPM2B Functions

Main function	Variations/Details	
Interrupts	Interrupt inputs 4 inputs, see note 1. Response time: 50 μs	
	Interval timer interrupts 1 input Set value: 0.5 to 319,968 ms Precision: 0.1 ms	Scheduled interrupts One-shot interrupt
High-speed counters	High-speed counter 1 input, see note 2. Differential phase mode (5 kHz) Pulse plus direction input mode (20 kHz) Up/down input mode (20 kHz) Increment mode (20 kHz)	No interrupt Count-check interrupt (An interrupt can be generated when the count equals the set value or the count lies within a preset range.)
	Interrupt inputs in counter mode 4 inputs, see note 1. Incrementing counter (2 kHz) Decrementing counter (2 kHz)	No interrupt Count-up interrupt
Pulse outputs	2 outputs: Single-phase pulse output without acceleration/deceleration (See note 3.) 10 Hz to 10 kHz 2 outputs: Variable duty ratio pulse output (See note 3.) 0.1 to 999.9 Hz, duty ratio 0 to 100% 1 output: Pulse output with trapezoidal acceleration/deceleration (See note 3.) Pulse plus direction output, up/down pulse output, 10 Hz to 10 kHz	
Synchronized pulse control	1 point, see notes 2 and 3. Input frequency range: 10 to 500 Hz, 20 Hz to 1 kHz, or 300 Hz to 20 kHz Output frequency range: 10 Hz to 10 kHz	
Quick-response input	4 inputs, see note 1. Maximum input signal width: 50 μs	
Analog settings	2 controls (setting ranges: 0 to 200 BCD)	
Input time constant	Determines the input time constant for all inputs. (Settings: 1, 2, 3, 5, 10, 20, 40, or 80 ms)	
Calendar/Clock	Shows the current year, month, day of the week, day of the month, hour, minute, and second.	
Error log	Records the time of occurrence and error code.	

- Note**
1. These four inputs are shared by interrupt inputs, interrupt inputs in counter mode, and quick-response inputs, but each input can be used for only one purpose.
 2. This input is shared by the high-speed counter and synchronized pulse control functions.
 3. This output is shared by the pulse output and synchronized pulse control functions. These functions can be used with transistor outputs only.

1-2 System Configurations

1-2-1 CPU Boards

CPU Board with 32 I/O points
(Relay outputs)

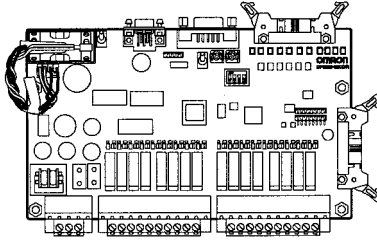

CPU Board with 32 I/O points
(Transistor outputs)

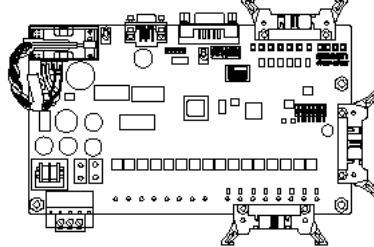

CPU Board with 40 I/O points
(Relay outputs)

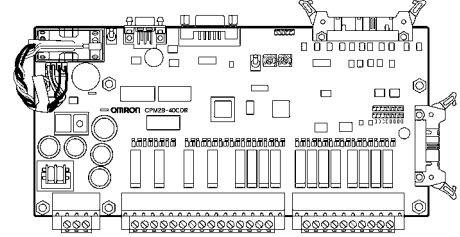

Power supply voltage	CPU Board	Inputs	Outputs	Built-in functions	Model
				Battery, Clock, and RS-232C port	
24 V DC	32 I/O points (16 inputs, 16 outputs)	16 inputs, 24 V DC	16 relay outputs (Terminal-block)	---	CPM2B-32C1DR-D
				Yes	CPM2B-32C2DR-D
	40 I/O points (24 inputs, 16 outputs)	24 inputs, 24 V DC	16 sinking transistor outputs (Connector)	---	CPM2B-32C1DT-D
				Yes	CPM2B-32C2DT-D
12 V DC	32 I/O points (16 inputs, 16 outputs)	16 inputs, 12 V DC	16 relay outputs (Terminal-block)	Yes	CPM2B-40C2DR-D
				---	CPM2B-32C1D1T-D12
				Yes	CPM2B-32C2D1T-D12

1-2-2 Expansion I/O Boards

The CPU Board can be connected with up to three Expansion I/O Boards, which are available in five models, including 32, 40, or 64 I/O points, and with either relay or sinking transistor outputs. For details on the number of Expansion I/O Boards that can be connected, refer to 3-1-4 Number of Expansion Boards.

Expansion I/O Board with 32 I/O points (Relay outputs)

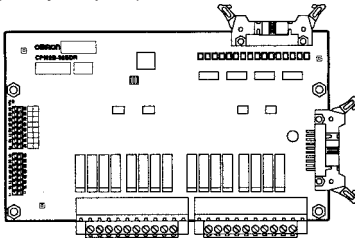

Expansion I/O Board with 40 I/O points (Relay outputs)

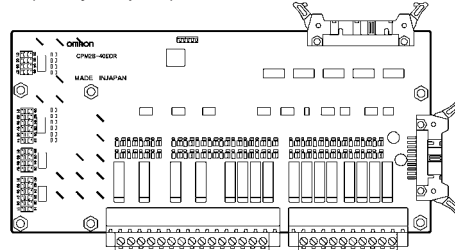

Expansion I/O Board with 32 I/O points (Transistor outputs)

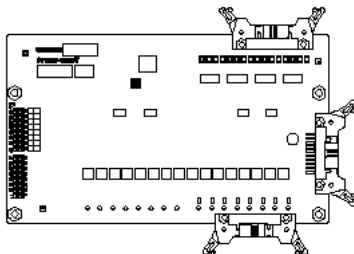

Expansion I/O Board with 64 I/O points (Transistor outputs)

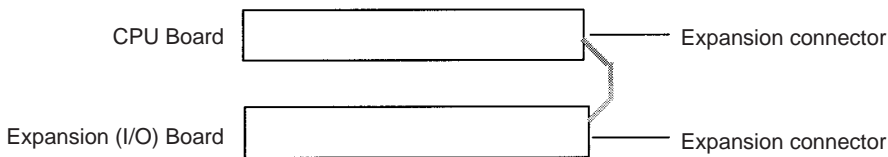
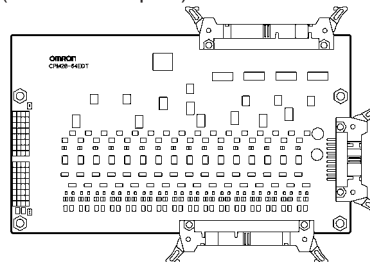

A PLC with 168 I/O points (the maximum) can be assembled by connecting two Expansion I/O Boards. The following configuration provides 88 inputs and 80 sinking transistor outputs:

$$\text{CPM2B-40C2DR-D (24 inputs, 16 outputs)} \times 1 \text{ Board} + \text{CPM2B-64EDT (32 inputs, 32 outputs)} \times 2 \text{ Boards} = 88 \text{ inputs, } 80 \text{ outputs}$$

Expansion I/O Boards

Expansion I/O Board	Inputs	Outputs	Model	Number of allocated words
32 I/O points (16 inputs, 16 outputs)	16 inputs, 24 V DC	16 relay outputs (Terminal-block)	CPM2B-32EDR	Input: 1 word Output: 1 word
	16 inputs, 24 V DC	16 sinking transistor outputs (Connector)	CPM2B-32EDT	Input: 1 word Output: 1 word
	16 inputs, 12 V DC		CPM2B-32ED1T	
40 I/O points (24 inputs, 16 outputs)	24 inputs, 24 V DC	16 relay outputs (Terminal-block)	CPM2B-40EDR	Input: 2 words Output: 2 words
64 I/O points (32 inputs, 32 outputs)	32 inputs, 24 V DC	32 sinking transistor outputs (Connector)	CPM2B-64EDT	Input: 2 words Output: 2 words

Note When an NT-AL001-E Adapter is connected to the RS-232C port, only one Expansion I/O Board can be connected because of power supply limitations.

1-2-3 Analog I/O Boards

Analog I/O Boards are Expansion Boards that have built-in analog input and output functions. Up to three Analog I/O Boards with a maximum of eight analog inputs and four analog outputs can be connected to a single CPU Board. For further details on the number of Analog I/O Boards that can be connected, refer to 3-1-4 *Number of Expansion Boards*.

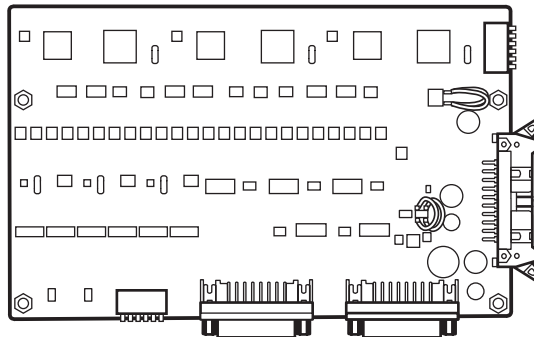

Analog input		Analog output		Resolu- tion	Model	Allocated words	Maximum number of Boards		
Input signal range	Number of inputs	Output signal range	Number of outputs						
0 to 5 V, 1 to 5 V, 0 to 10 V, -10 to 10 V, 0 to 20 mA, and 4 to 20 mA	6 points	1 to 5 V, 0 to 10 V, -10 to 10 V, 0 to 20 mA, and 4 to 20 mA	3 points	6,000	CPM2B-MAD63	Input: 6 words Output: 3 words	1		
	4 points		2 points					CPM2B-MAD42	Input: 4 words Output: 2 words
	2 points		1 point					CPM2B-MAD21	Input: 2 words Output: 1 words

1-2-4 Connecting a Programming Console

A Programming Console can be connected to the CPM2B CPU Board's peripheral port, as shown below.

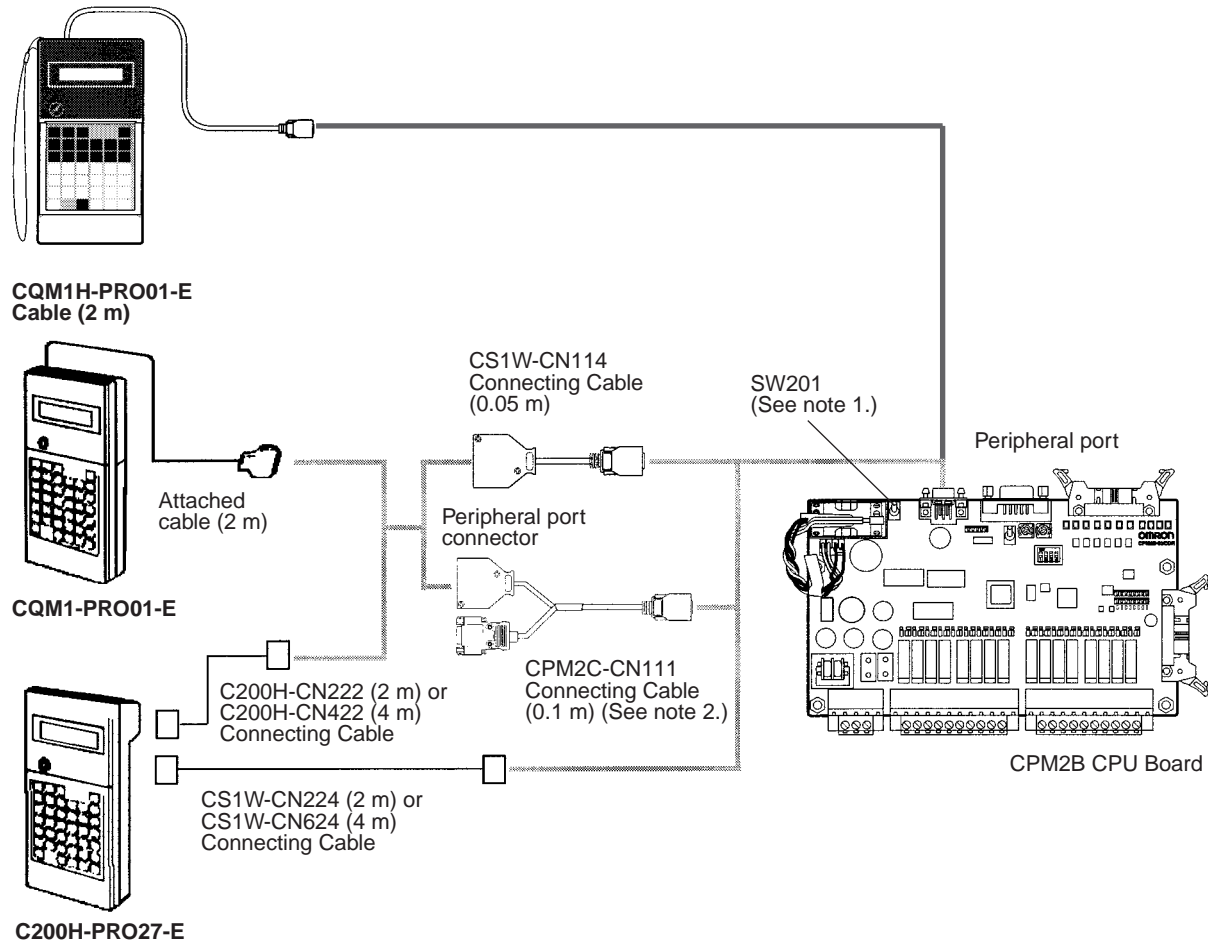

- Note**
1. Always turn OFF SW 201 before connecting the Programming Console.
 2. Only the peripheral port connector can be used when a CPM2C-CN111 Connecting Cable is connected.

1-2-5 Support Software

A personal computer running the CX-Programmer (version 1.2 or later) or the SSS can be connected to the CPU Board's Peripheral port or RS-232C port. Refer to 1-2-6 *One-to-one Computer Connections* for details on the computer connection.

Always turn ON Communications Switch SW201 when using Support Software instead of a Programming Console. The setting on Communications Switch SW202 determines whether the communications settings in the PLC Setup or the standard settings will be used, as shown in the following table.

SW202 setting	Communications settings	
	Peripheral port	RS-232C port
ON	Standard settings (The standard settings and PLC Setup default settings are Host Link communications at 9,600 bps with 1 start bit, 7-bit data, 2 stop bits, and even parity.)	
OFF	PLC Setup settings in DM 6650 and DM 6651	PLC Setup settings in DM 6645 and DM 6646

When using the SSS, set the PLC Model to "CQM1."

When using the CX-Programmers, set the PLC Model to "CPM2*." (The CX-Programmer must be version 1.2 or later.)

1-2-6 One-to-one Computer Connections

Connect a personal computer to the peripheral port or RS-232C port of the CPM2B CPU Board when using the CX-Programmer, 1:1 Host Link communications, or no-protocol (serial) communications.

RS-232C Port Connection

For communications using the CX-Programmer, select **SYSMAC WAY** as the *Network Type* (Serial Communications Mode). Communications will not be possible if *Toolbus* is selected.

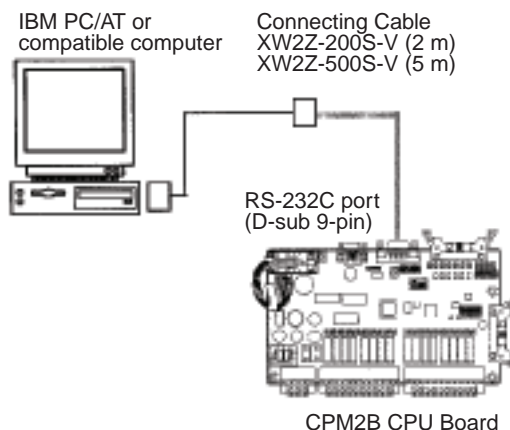

Peripheral Port Connection

For communications using the CX-Programmer, select **Toolbus** or **SYSMAC WAY** as the *Network Type* (Serial Communications Mode).

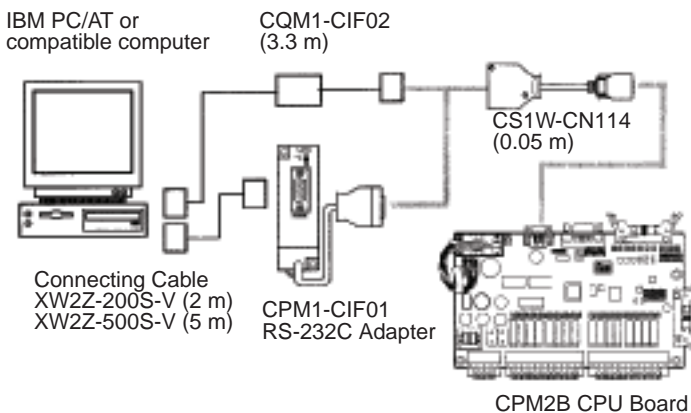

Note The CQM1-CIF11 Connecting Cable cannot be used. (If one is connected, the CPM2C will not recognize it; the PLC will enter RUN mode at startup if Com-

munications Switch SW201 is ON and DM 6600 of the PLC Setup is set to its default setting so that the Programming Console's mode switch controls the startup mode.)

1-2-7 One-to-N Computer Connections

Up to 32 OMRON PLCs, including CPM2B PLCs, can be connected to a host computer.

Using the RS-232C Port

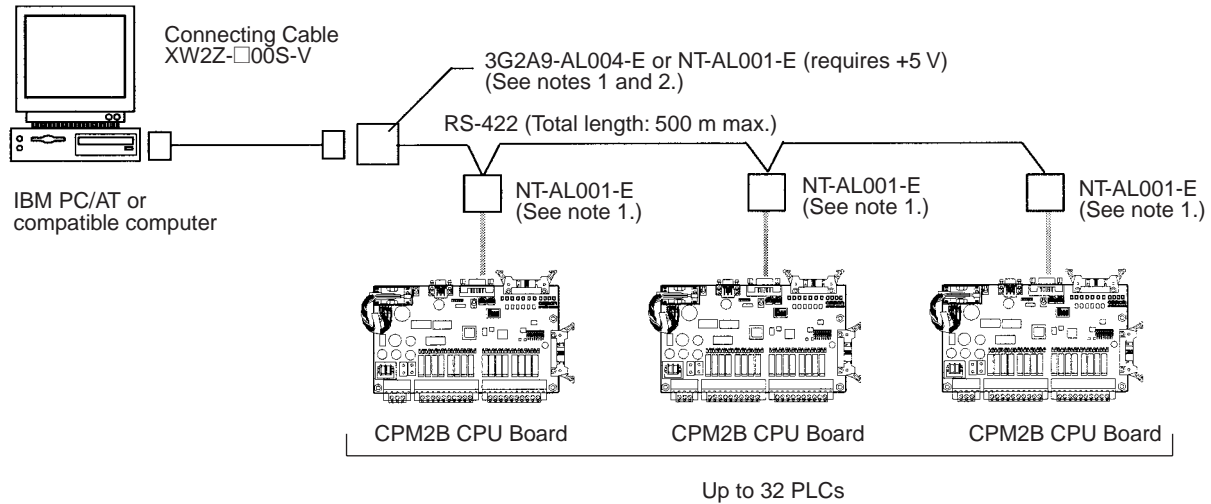

Using the Peripheral Port

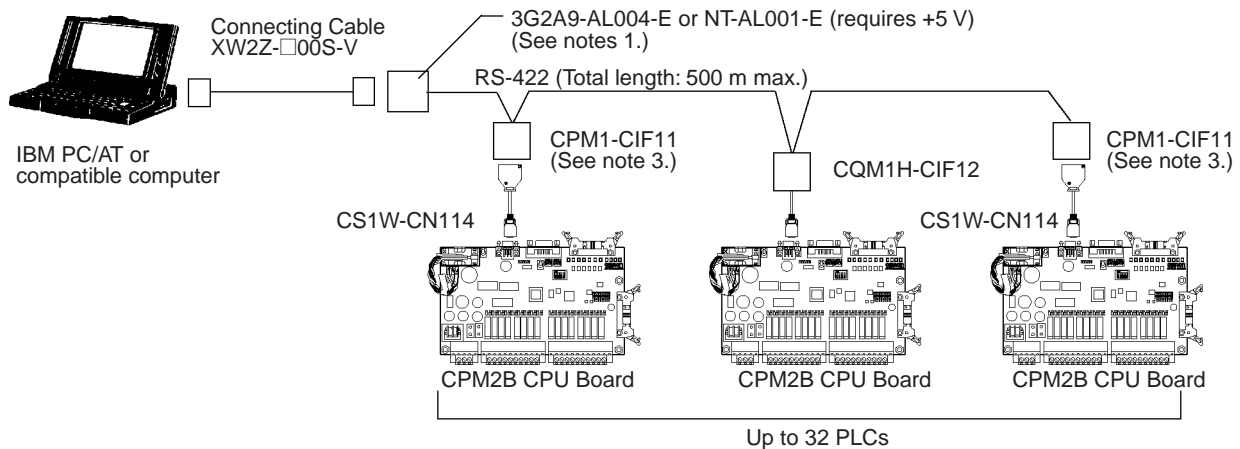

- Note**
1. The NT-AL001-E must be supplied externally with 5 V DC. When an NT-AL001-E is connected to a CPM2B PLC, pin 6 of the CPM2B's RS-232C port supplies +5 V DC and an external power supply is not necessary. When the NT-AL001-E is connected to a host computer, it is necessary to supply 5 V DC from an external power supply.
If an NT-AL001-E is connected to the CPM2B's RS-232C port, only one Expansion I/O Board can be connected to the CPU Board because the NT-AL001-E draws its 5-V DC power from the CPU Board.
Use an XW2Z-070T-1 (0.7 m) or XW2Z-200T-1 (2 m) cable to connect the NT-AL001-E to the CPM2B's RS-232C port.
 2. The 3G2A9-AL004-E requires an external AC power supply (110 V AC or 220 V AC).

- The CPM1-CIF11 is supplied +5 V DC from the peripheral port so an external power supply is not necessary.

1-2-8 OMRON PT Connections

In a 1:1 NT Link, a CPM2B can be connected directly to a Programmable Terminal through the RS-232C port. (The Programmable Terminal cannot be connected directly to the peripheral port.)

An OMRON PT can also be connected to the CPM2B with a host link connection. Either the RS-232C port or peripheral port can be used for a host link connection.

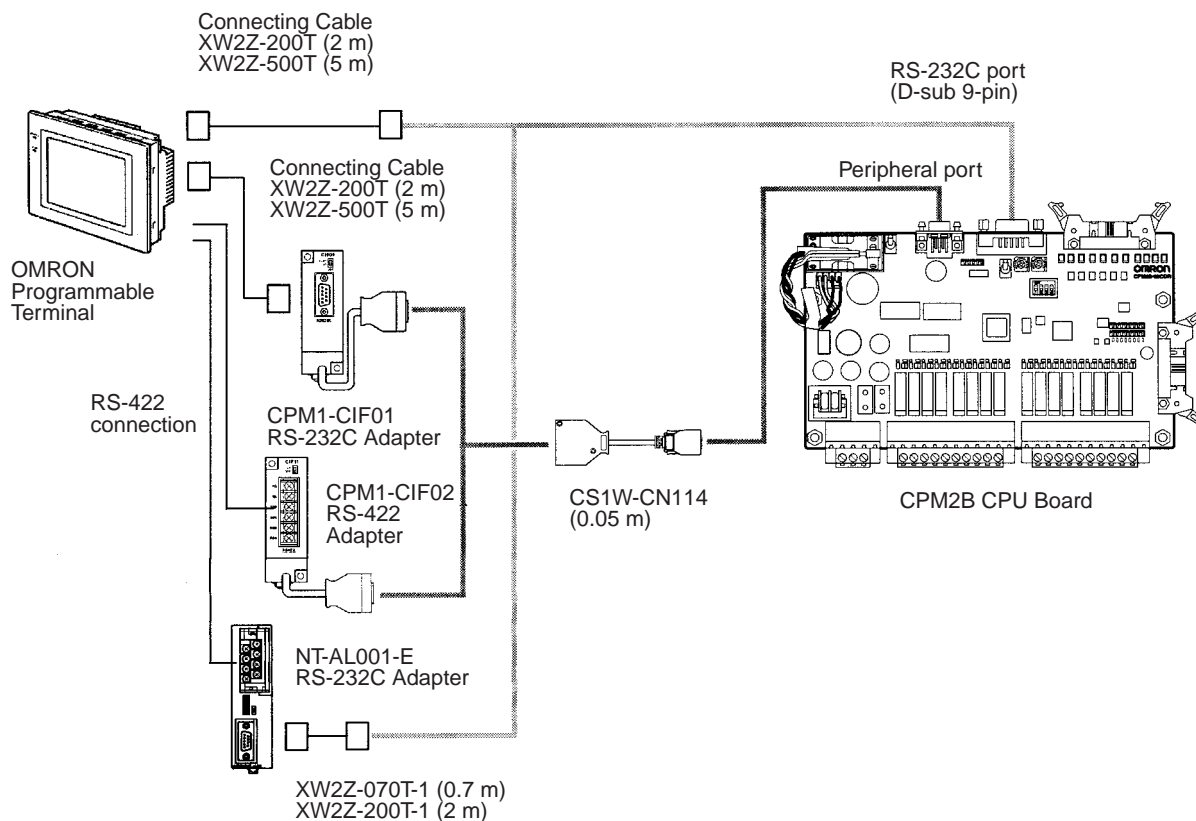

Note When the PLC is in RUN mode with a Programming Console connected to the peripheral port, if a PT is connected to the RS-232C port via Host Link, the Programming Console will display a message prompting the user to enter a password. (For details, refer to *Section 7-2 Programming Console Operations*.) This is because, in order to write data to the PLC, the PT automatically switches the operating mode from RUN mode to MONITOR mode.

- This automatic mode change will not be performed if the PT is connected via NT Link.
- When a Programming Device installed on a computer is connected to the peripheral port, the display (at the computer) for the CPU Unit's operating mode will simply change from "RUN" to "MONITOR."

1-2-9 One-to-one PLC Link Connections

A CPM2B can be linked to another CPM2B, a CQM1, CPM1, CPM1A, CPM2A, CPM2C, SRM1 (-V2) or a C200HS or C200HX/HG/HE PLC. The PLCs must be connected through the RS-232C ports; they cannot be connected through the Peripheral ports.

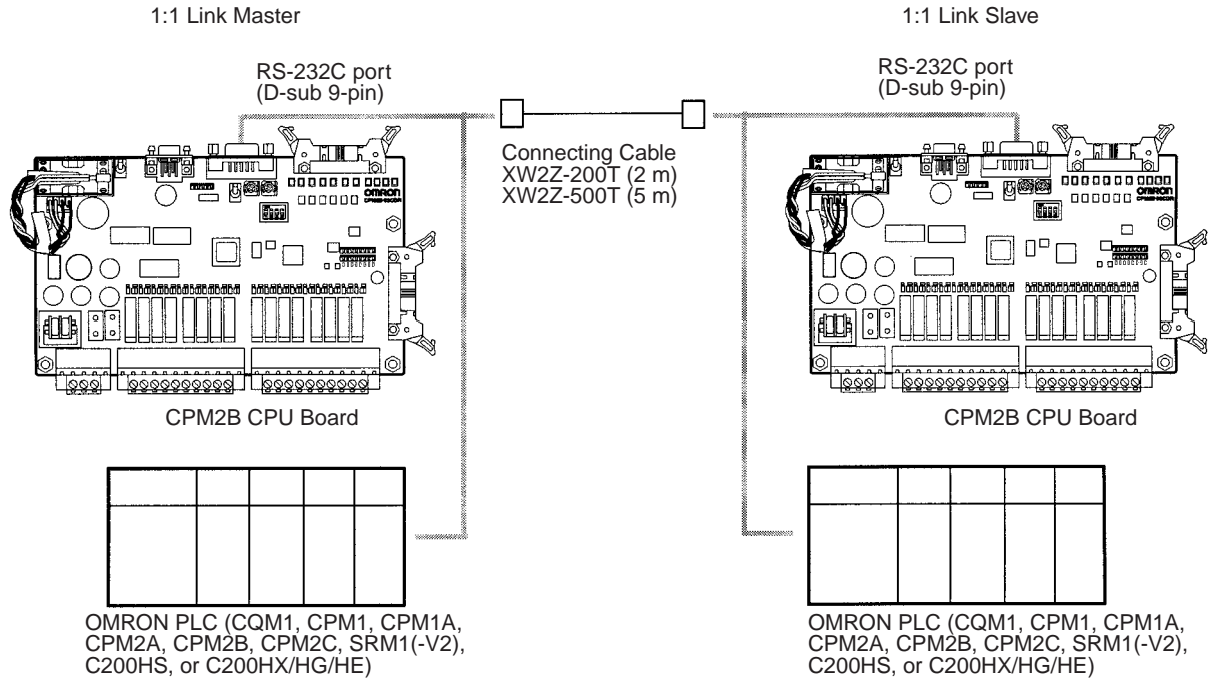

1-3 Structure and Operation

1-3-1 CPU Board Structure

The following diagram shows the internal structure of the CPU Board.

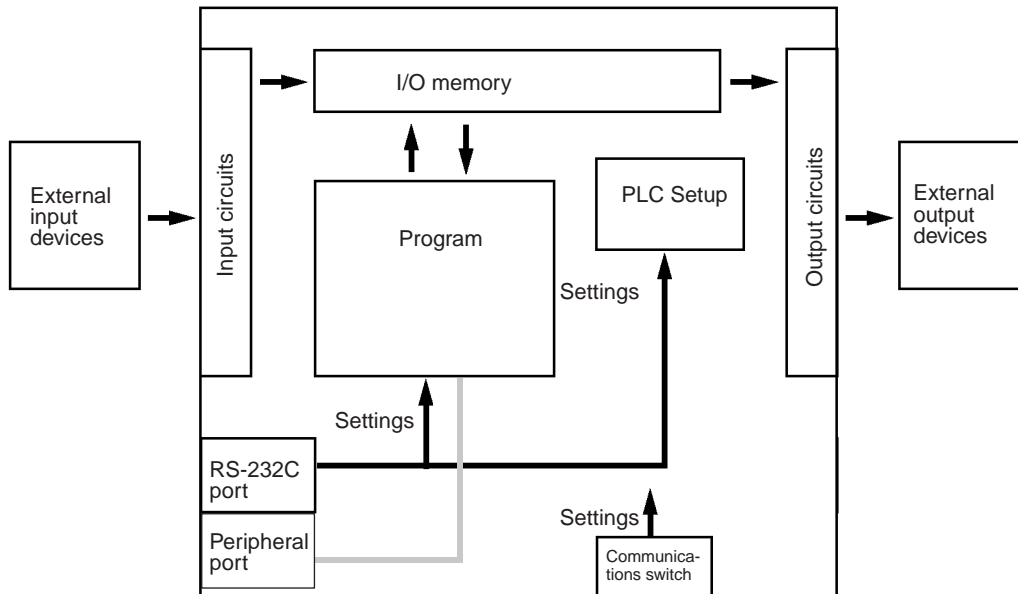

I/O Memory	<p>The program reads and writes data in this memory area during execution. Part of the I/O memory contains the bits that reflect the status of the PLC's inputs and outputs. Parts of the I/O memory are cleared when the power is turned ON and other parts are retained.</p> <p>Note Refer to <i>SECTION 4 Memory Areas</i> for more details on I/O memory.</p>
Program	<p>This is the program written by the user. The CPM2B executes the program cyclically. (Refer to <i>1-3-5 Cyclic Operation and Interrupts</i> for details.)</p> <p>The program can be divided broadly into two parts: the "main program" that is executed cyclically and the "interrupt programs" that are executed only when the corresponding interrupt is generated.</p>
PLC Setup	<p>The PLC Setup contains various startup and operating parameters. The PLC Setup parameters can be changed from a Programming Device only; they cannot be changed from the program.</p> <p>Some parameters are accessed only when PLC's power supply is turned on and others are accessed regularly while the power is on. It will be necessary to turn the power off and then on again to enable a new setting if the parameter is accessed only when the power is turned ON.</p> <p>Note Refer to <i>4-5 PLC Setup</i> for more details.</p>
Communications Switches	<p>The Communications Switches determine whether the peripheral port and RS-232C port operate with the standard communications settings or the communications settings in the PLC Setup. Refer to <i>2-2 Board Components and their Functions</i> for more details.</p>

1-3-2 Operating Modes

CPM2B CPU Boards have 3 operating modes: PROGRAM, MONITOR, and RUN.

PROGRAM Mode	<p>The program cannot be executed in PROGRAM mode. This mode is used to perform the following operations in preparation for program execution</p> <ul style="list-style-type: none">• Changing initial/operating parameters such as those in the PLC Setup• Writing, transferring, or checking the program• Checking wiring by force-setting and force-resetting I/O bits <p> Caution The PLC continues to refresh I/O bits even if the PLC is in PROGRAM mode, so devices connected to output points on the CPU Board or Expansion I/O Boards may operate unexpectedly if the corresponding output bit is turned ON by changing the contents of I/O memory from a Programming Device.</p>
MONITOR Mode	<p>The program is executed in MONITOR mode and the following operations can be performed from a Programming Device. In general, MONITOR mode is used to debug the program, test operation, and make adjustments.</p> <ul style="list-style-type: none">• Online editing• Monitoring I/O memory during operation• Force-setting/force-resetting I/O bits, changing set values, and changing present values during operation
RUN Mode	<p>The program is executed at normal speed in RUN mode. Operations such as online editing, force-setting/force-resetting I/O bits, and changing set values/present values cannot be performed in RUN mode, but the status of I/O bits can be monitored.</p>

1-3-3 Operating Mode at Startup

The operating mode of the CPM2B when the power is turned ON depends upon the PLC Setup settings and the Programming Console's mode switch setting if a Programming Console is connected.

PLC Setup setting			Operating mode
Word	Bits	Setting	
DM 6600	08 to 15	00	See note.
		01	Startup mode is the same as the operating mode before power was interrupted.
		02	Startup mode is determined by bits 00 to 07.
	00 to 07	00	PROGRAM mode
		01	MONITOR mode
		02	RUN mode

Note The startup mode depends upon the setting of Communications Switch SW201 and the Programming Device connected to the peripheral port.

Programming Device	SW201 OFF	SW201 ON
None	PROGRAM mode	RUN mode (see note 2)
Programming Console	Operating mode set on the Programming Console's mode switch	PROGRAM mode (see note 1)
Other device	PROGRAM mode (see note 1)	PROGRAM mode

- Note**
1. The CPM2B will not be able to communicate with the Programming Device in these cases.
 2. The default setting of bits 08 to 15 of DM 6600 is 00. With this default setting, the PLC will automatically enter RUN mode if a Programming Console is not connected and SW201 is ON. Be sure that it is safe for the PLC to operate before turning it ON under these conditions.

1-3-4 PLC Operation at Startup

Time Required for Initialization

The time required for startup initialization depends on several factors, such as the operating conditions (including power supply voltage, system configuration, and ambient temperature) and the program contents.

Power OFF Operation

Minimum Power Supply Voltage

The PLC will stop and all outputs will be turned OFF if the power supply voltage falls below 85% of the rated value.

Momentary Power Interruption

A power interruption will not be detected and CPU Board operation will continue if the power interruption lasts less than 2 ms for a DC power supply.

A power interruption may or may not be detected for power interruptions somewhat longer than 2 ms for a DC power supply.

When a power interruption is detected, the CPU Board will stop operating and all outputs will be turned OFF.

Automatic Reset

Operation will restart automatically when the power supply voltage is restored to more than 85% of the rated voltage.

Timing Chart of Power OFF Operation

The power interruption detection time is the time required for a power interruption to be detected after the power supply voltage drops below 85% of the rated value.

- 1,2,3...
1. Minimum power interruption detection time
Power interruptions that are shorter than 2 ms will not be detected.
 2. Undetermined additional time
Power interruptions only slightly longer than the minimum power interruption time may not be detected.

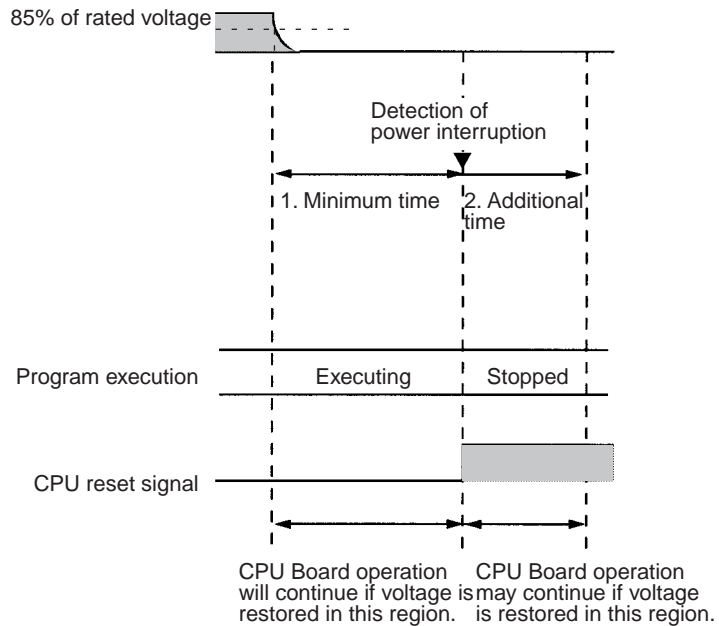

Note If the power supply voltage fluctuates around 85% of the PLC's rated voltage, PLC operation may stop and restart repeatedly. When repeated stopping and starting will cause problems with the controlled system, set up a protective circuit such as a circuit that shuts off the power supply to sensitive equipment until the power supply voltage returns to the rated value.

1-3-5 Cyclic Operation and Interrupts

Basic CPU Operation

Initialization processing is performed when the power is turned on. If there are no initialization errors, the overseeing processes, program execution, I/O refreshing, and communications port servicing are performed repeatedly (cyclically).

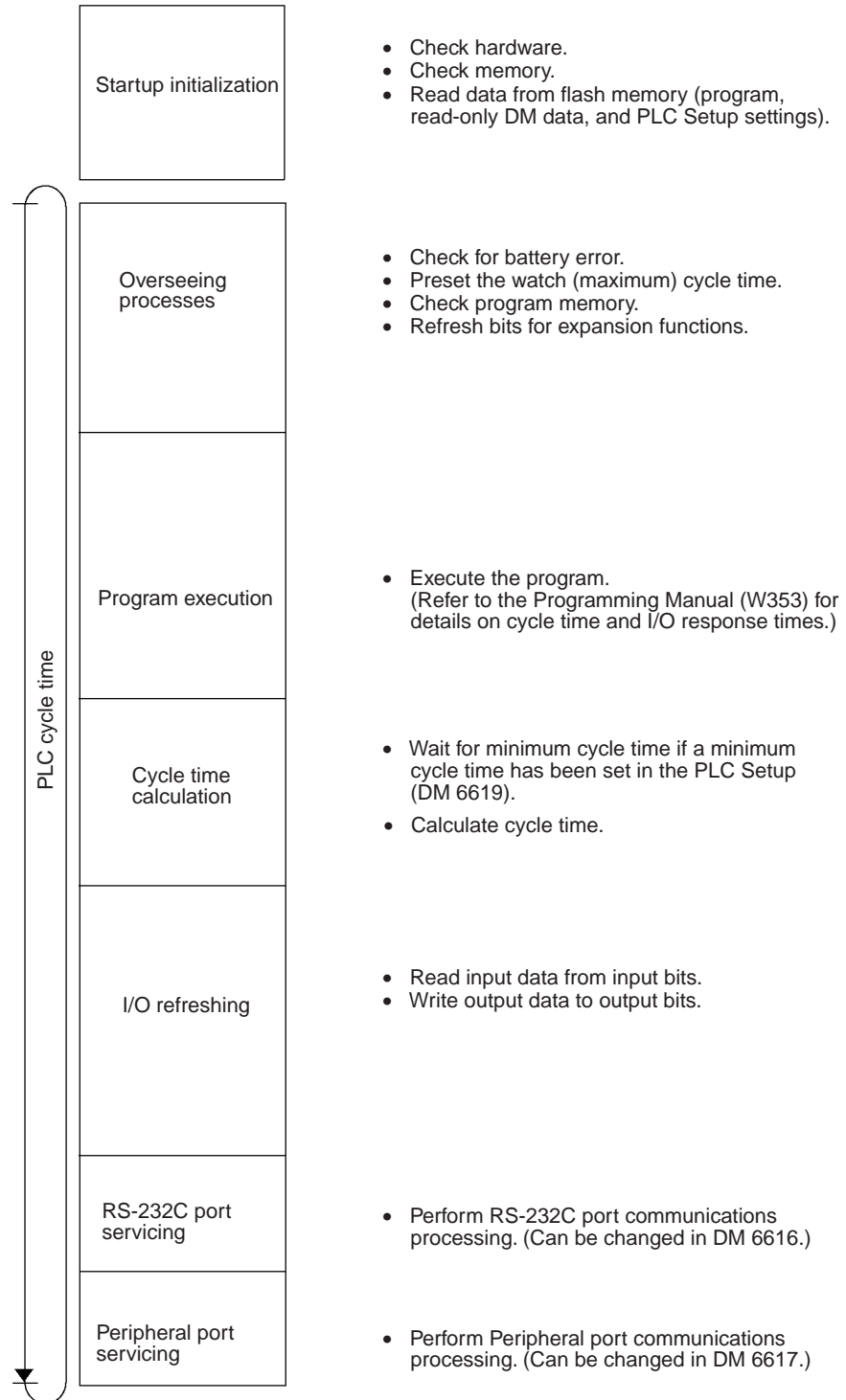

The cycle time can be read from a Programming Device.

AR 14 contains the maximum cycle time and AR 15 contains the present cycle time in 4-digit BCD.

Program Execution in Cyclic Operation

The cycle time will vary slightly depending on the processing being performed in each cycle, so the calculated cycle time will not always match the actual cycle time.

The following diagram shows the cyclic operation of the CPM2B when the program is being executed normally.

Normally, the results of program execution are transferred to I/O memory just after program execution (during I/O refreshing), but IORF(97) can be used to refresh a specified range of I/O words during program execution. The specified range of I/O words will be refreshed when IORF(97) is executed.

The cycle time is the sum of the time required for program execution, I/O refreshing, and communications port servicing.

A minimum cycle time (1 to 9,999 ms) can be set in the PLC Setup (DM 6619). When a minimum cycle time has been set, CPU operation is paused after program execution until the minimum cycle time is reached. CPU operation will not be paused if the actual cycle time is longer than the minimum cycle time set in DM 6619.

Note A fatal error will occur and PLC operation will stop if a maximum cycle time has been set in the PLC Setup (DM 6618) and the actual cycle time exceeds that setting.

The default settings for RS-232C port servicing and Peripheral port servicing are 5% of the cycle time, but these settings can be changed (between 1% and 99%) in the PLC Setup. The RS-232C port's setting is in DM 6616 and the Peripheral port's setting is in DM 6617.

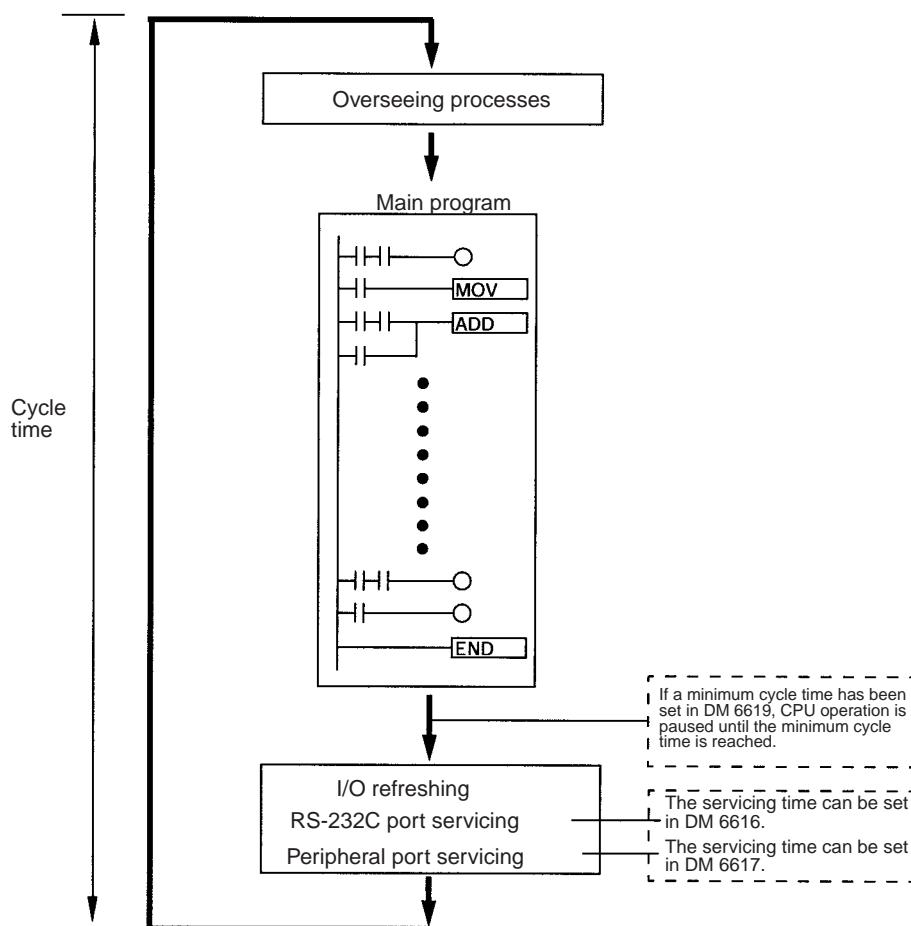

Interrupt Program Execution

When an interrupt is generated during execution of the main program, main program execution is interrupted immediately and the interrupt program is executed. The following diagram shows the cyclic operation of the CPM2B when an interrupt program is executed.

Normally, the results of interrupt program execution are transferred to I/O memory just after program execution (during I/O refreshing), but IORF(97) can be used to refresh a specified range of I/O words during execution of the interrupt program. The specified range of I/O words will be refreshed when IORF(97) is executed.

The normal cycle time is extended by the time required for execution of the interrupt program.

Refer to *Section 7 PLC Operations and Processing Time* in the *CPM1/CPM1A/CPM2A/CPM2C/SRM1(-V2) Programmable Controllers Programming Manual (W353)* for more details and precautions on the cycle time.

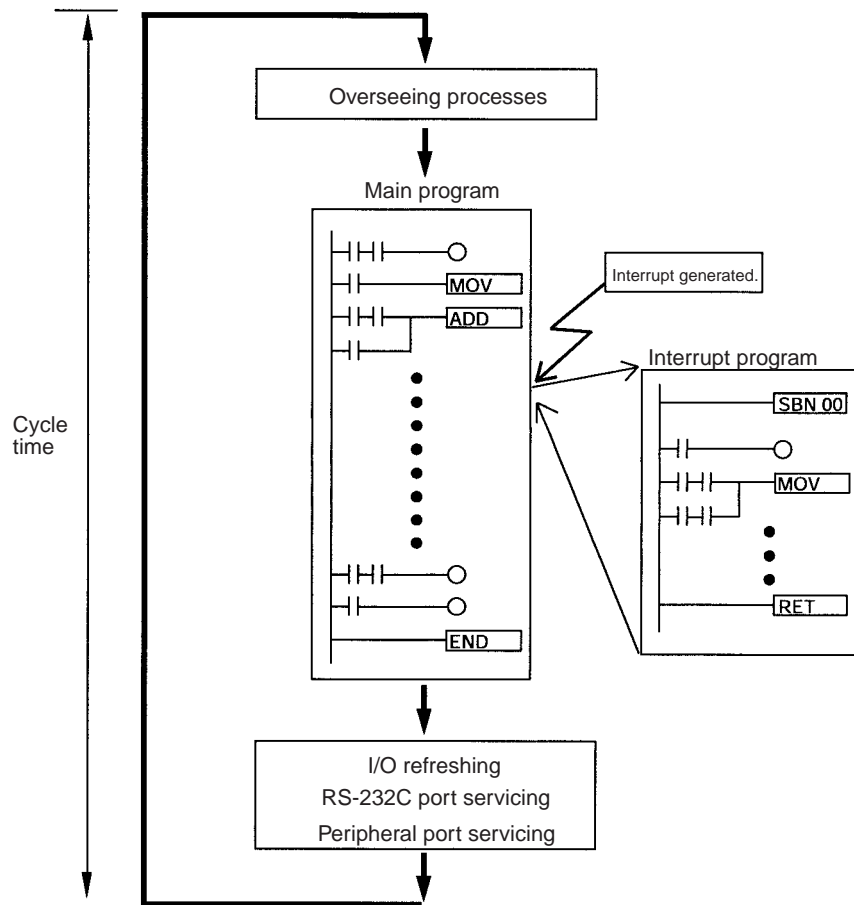

⚠ Caution Although IORF(97) can be used in interrupt subroutines, you must be careful of the interval between IORF(97) executions. If IORF(97) is executed too frequently, a fatal system error may occur (FALS 9F), stopping operation. The interval between executions of IORF(97) should be at least 1.3 ms + total execution time of the interrupt subroutine.

Immediate Refreshing

IORF(97) can be executed in the program to refresh a specified range of I/O words. The specified I/O words will be refreshed when IORF(97) is executed. IORF(97) can be used to refresh I/O from the main program or the interrupt program.

When IORF(97) is used, the cycle time is extended by the time required to refresh the specified I/O words.

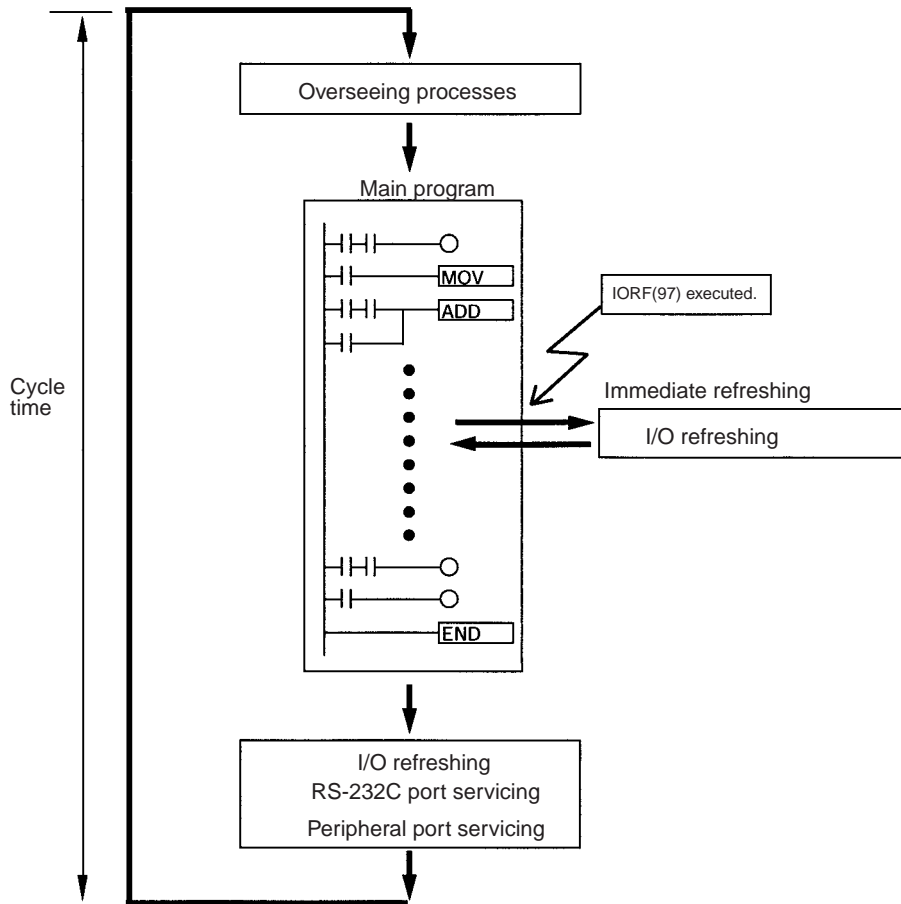

SECTION 2

Board Specifications and Components

This section provides the technical specifications of the CPM2B Boards and describes the main components of the Boards.

2-1	Specifications	24
2-1-1	General Specifications	24
2-1-2	Characteristics	25
2-1-3	I/O Specifications	27
2-2	Board Components and their Functions	34
2-2-1	CPU Board Components	34
2-2-2	Expansion I/O Boards	37
2-3	I/O Connector and Terminal Pin Allocation	40

2-1 Specifications

2-1-1 General Specifications

Item	CPU Boards		Expansion I/O Boards	
	With relay outputs	With transistor outputs	With relay outputs	With transistor outputs
Model	CPM2B-32C□DR-D CPM2B-40C2DR-D	CPM2B-32C□DT-D	CPM2B-32C□DT1-D12	CPM2B-32EDR CPM2B-40EDR CPM2B-32EDT CPM2B-32ED1T CPM2B-64EDT
Supply voltage	24 V DC (Allowable range: 20.4 to 26.4 V DC)	12 V DC (Allowable range: 10.8 to 13.2 V DC)	Supplied from CPU Board.	
Power consumption	20 W max.		---	
Inrush current	20 A max.		---	
Insulation resistance	20 MΩ min. (at 500 V DC) between the external DC terminals and non-current carrying metal parts			
Dielectric strength	1,000 V AC 50/60 Hz for 1 min between the external DC terminals and non-current carrying metal parts			
Noise immunity	Conforms to IEC6100-4-4; 2 kV (power lines)			
Vibration resistance	10 to 57 Hz, 0.075-mm amplitude, 57 to 150 Hz, acceleration: 9.8 m/s ² in X, Y, and Z directions for 80 minutes each (8 minutes of vibration × 10 repetitions= total time 80 minutes)			
Shock resistance	147 m/s ² three times each in X, Y, and Z directions			
Ambient temperature	Operating: 0 to 55°C Storage: -20 to 75°C (excluding the battery)			
Ambient humidity	Operating: 10% to 90% (with no condensation)			
Ambient atmosphere	Operating: Must be free from corrosive gas			
I/O configuration	Inputs: Connector Outputs: Terminal block	Inputs: Connector Outputs: Connector	Inputs: Connector Outputs: Terminal block	Inputs: Connector Outputs: Connector
Power supply retention time	2 ms min.			

2-1-2 Characteristics

Item		CPU Boards	
		With relay outputs	With transistor outputs
Control method		Stored program method	
I/O control method		Cyclic scan with direct output (Immediate refreshing can be performed with IORF(97).)	
Programming language		Ladder diagram	
Instruction length		1 step per instruction, 1 to 5 words per instruction	
Instructions	Basic instructions	14	
	Special instructions	105 instructions, 185 variations	
Execution time	Basic instructions	0.64 μ s (LD instruction)	
	Special instructions	7.8 μ s (MOV instruction)	
Program capacity		4,096 words	
Max. I/O capacity	CPU Board only	32 points/40 points	
	With Expansion I/O Boards	168 points max.	
Input bits		IR 00000 to IR 00915 (Words not used for input bits can be used for work bits.)	
Output bits		IR 01000 to IR 01915 (Words not used for output bits can be used for work bits.)	
Work bits		928 bits: IR 02000 to IR 04915 and IR 20000 to IR 22715	
Special bits (SR Area)		448 bits: SR 22800 to SR 25515	
Temporary bits (TR Area)		8 bits (TR0 to TR7)	
Holding bits (HR Area)		320 bits: HR 0000 to HR 1915 (Words HR 00 to HR 19)	
Auxiliary bits (AR Area)		384 bits: AR 0000 to AR 2315 (Words AR 00 to AR 23)	
Link bits (LR Area)		256 bits: LR 0000 to LR 1515 (Words LR 00 to LR 15)	
Timers/Counters		256 timers/counters (TIM/CNT 000 to TIM/CNT 255) 1-ms timers: TMHH(—) 10-ms timers: TIMH(15) 100-ms timers: TIM 1-s/10-s timers: TIML(—) Decrementing counters: CNT Reversible counters: CNTR(12)	
Data memory	Read/Write	2,048 words (DM 0000 to DM 2047) The Error Log is contained in DM 2000 to DM 2021.	
	Read-only	456 words (DM 6144 to DM 6599)	
	PLC Setup	56 words (DM 6600 to DM 6655)	
Interrupt processing	External interrupts	4 (Also used for external interrupt inputs in counter mode and quick-response inputs.)	
	Interval timer interrupts	1 (Scheduled Interrupt Mode or Single Interrupt Mode)	
High-speed counter	High-speed counter	1 (20 kHz single-phase or 5 kHz two-phase (linear count method))	
	Counter interrupt	1 (set value comparison or set-value range comparison)	
	Interrupt Inputs (Counter mode)	4 inputs (Also used for interrupt inputs and quick-response inputs.)	
	Counter interrupts	4 (Also used for the external interrupt inputs and quick-response inputs.)	
Pulse output		2 points with no acceleration/deceleration, 10 Hz to 10 kHz each, and no direction control. 1 point with trapezoidal acceleration/deceleration, 10 Hz to 10 kHz, and direction control. 2 points with variable duty-ratio outputs. (Pulse outputs can be used with transistor outputs only, they cannot be used with relay outputs.)	

Item	CPU Boards	
	With relay outputs	With transistor outputs
Synchronized pulse control	1 point: A pulse output can be created by combining the high-speed counter with pulse outputs and multiplying the frequency of the input pulses from the high-speed counter by a fixed factor. (This output is possible with transistor outputs only, it cannot be used with relay outputs.)	
Quick-response inputs	4 points (Min. input pulse width: 50 μs max.) (Also used for interrupt inputs and for interrupt inputs in counter mode.)	
Input time constant (ON response time = OFF response time)	Can be set for all input points. (1 ms, 2 ms, 3 ms, 5 ms, 10 ms, 20 ms, 40 ms, or 80 ms) This constant, however, is fixed to 1 ms for 40 and 64 I/O-point Expansion I/O Boards.	
Clock function	Shows the year, month, day of the week, day, hour, minute, and second. (Backed up by the battery.) (The clock function is available only in CPU Boards equipped with a clock.)	
Communications functions	Built-in peripheral port: Supports Host Link, peripheral bus, no-protocol, or Programming Console connections. Built-in RS-232C port: Supports Host Link, no-protocol, 1:1 PLC Link (Master/Slave), or 1:1 NT Link connections. (RS-232C communications are available only in CPU Boards equipped with an RS-232C port.)	
Memory protection (See notes 1 and 2.)	HR Area, AR Area, program contents, read/write DM Area contents, and counter values maintained during power interruptions.	
Memory backup (See notes 1 and 2.)	Flash memory: Program, read-only DM Area, and PLC Setup Battery or capacitor backup: The read/write DM Area, HR Area, AR Area, and counter values are backed up by a battery. CPU Boards with clock: Backup is approximately 5 years at 25°C. CPU Boards without clock: Backup is approximately 5 days at 25°C.	
Self-diagnostic functions	CPU error (watchdog timer), I/O bus error, battery error, and memory error	
Program checks	No END instruction, programming errors (checked when operation is started)	

- Note**
1. The DM Area, HR Area, AR Area, and counter values are backed up by the CPU Board's built-in battery or capacitor. If the battery or capacitor is discharged, the contents of these areas will be lost and the data values will revert to the defaults.
 2. The contents of the program area, read-only DM Area (DM 6144 to DM 6599), and PLC Setup (DM 6600 to DM 6655) are stored in flash memory. The contents of these areas will be read from flash memory the next time the power is turned ON, even if the backup battery or capacitor is discharged.

 When data has been changed in any of these areas, write the new values to flash memory by switching the CPM2B to MONITOR or RUN mode, or by turning the power OFF and then ON again.

2-1-3 I/O Specifications

CPU Board Input Specifications

Item	Inputs	Specification	
Input voltage	All	24 V DC ^{+10%} / _{-15%}	12 V DC ^{+10%} / _{-15%}
Input impedance	IN00000 to IN00001	2.7 kΩ	1.5 kΩ
	IN00002 to IN00006	3.9 kΩ	2.0 kΩ
	IN00007 and up	4.7 kΩ	2.4 kΩ
Input current	IN00000 to IN00001	8 mA typical	8 mA typical
	IN00002 to IN00006	6 mA typical	6 mA typical
	IN00007 and up	5 mA typical	5 mA typical
ON voltage/current	IN00000 to IN00001	17 V DC min., 5 mA	9.5 V DC min., 5 mA
	IN00002 and up	14.4 V DC min., 3 mA	8.0 V DC min., 3 mA
OFF voltage/current	All	5.0 V DC max., 1 mA	
ON delay	All	1 to 80 ms max. Default: 10 ms (See note.)	
OFF delay	All	1 to 80 ms max. Default: 10 ms (See note.)	
Circuit configuration	IN00000 to IN00001		
	IN00002 to IN00006		
	IN00007 and up		

- Note**
1. The input time constant can be set to 1, 2, 3, 5, 10, 20, 40, or 80 ms in the PLC Setup. See page 84.
 2. The value in parentheses shows the resistance for the CPM2B-32C□D1T-D12.

Max. Number of Inputs Simultaneously ON

The maximum number of inputs that can be ON simultaneously depends upon the ambient operating temperature and the installation orientation, as shown in the following diagrams.

1,2,3...

1. Installation orientation: Vertical with edge down
With 32 and 40-point CPU Boards and Expansion I/O Boards, all inputs can be ON simultaneously with this orientation.

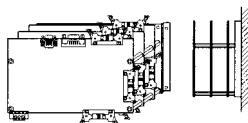

2. Installation orientation: Vertical with end down

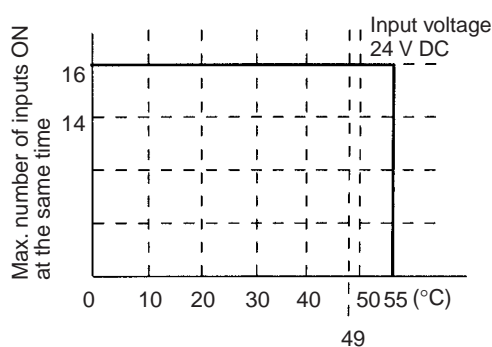
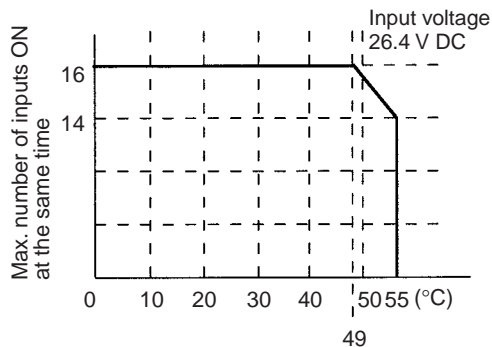
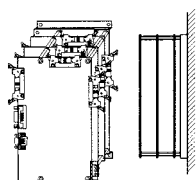

3. Installation orientation: Horizontal

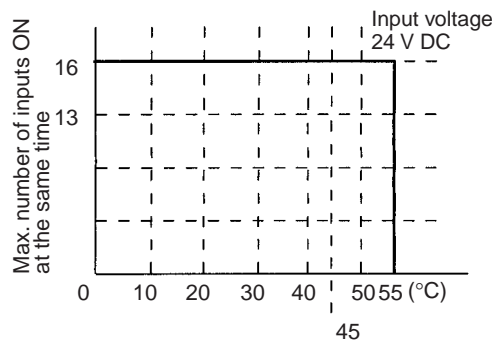
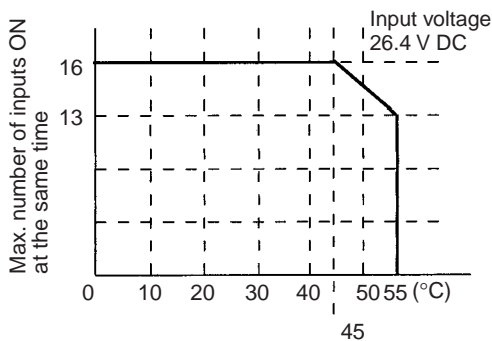
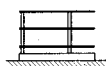

High-speed Counter Inputs

Inputs IN00000 through IN00002 can be used as high-speed counter inputs, as shown in the following table. The maximum count frequency is 5 kHz in differential phase mode and 20 kHz in the other modes.

Input	Function			
	Differential phase mode	Pulse plus direction input mode	Up/down input mode	Increment mode
IN00000	A-phase pulse input	Pulse input	Increment pulse input	Increment pulse input
IN00001	B-phase pulse input	Direction input	Decrement pulse input	Normal input
IN00002	Z-phase pulse input or hardware reset input (IN00002 can be used as a normal input when it is not used as a high-speed counter input.)			

The minimum pulse widths for inputs IN00000 (A-phase input) and IN00001 (B-phase input) are as follows:

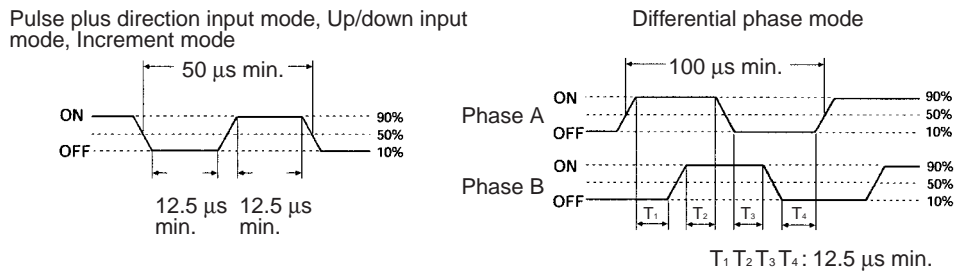

The minimum pulse width for input IN00002 (Z-phase input) is as follows:

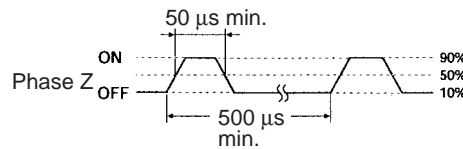

Interrupt Inputs

Inputs IN00003 through IN00006 can be used as interrupt inputs (interrupt input mode or counter mode) and quick-response inputs. The minimum pulse width for these inputs is 50 μs.

Expansion I/O Board Input Specifications

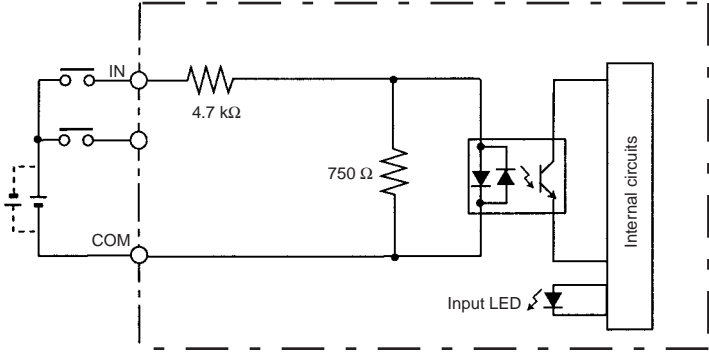
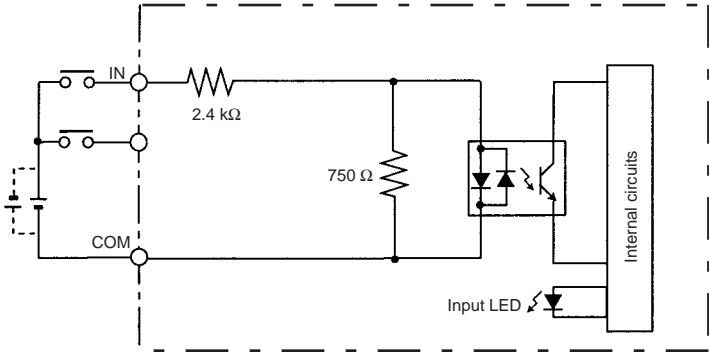
Item	Specification	
	CPM2B-32EDT/32EDR/40EDR/64EDT	CPM2B-32ED1T
Input voltage	24 V DC $+10\%/_{-15\%}$	12 V DC $+10%/_{-15\%}$
Input impedance	4.7 k Ω	2.4 k Ω
Input current	5 mA typical	5 mA typical
ON voltage	14.4 V DC min.	8.0 V DC, 3 mA min.
OFF voltage	5.0 V DC max.	3.0 V DC, 1 mA max.
ON delay	1 to 80 ms max. Default: 10 ms (See note.)	
OFF delay	1 to 80 ms max. Default: 10 ms (See note.)	
Circuit configuration	<ul style="list-style-type: none"> CPM2B-32EDT/32EDR/40EDR/64EDT  CPM2B-32ED1T  	

Note The input time constant can be set to 1, 2, 3, 5, 10, 20, 40, or 80 ms in the PLC Setup. See page 84. (The constant, however, is fixed to 1 ms for 40 and 64 I/O-point Expansion I/O Boards.)

CPU Board and Expansion I/O Board Output Specifications

Relay Outputs

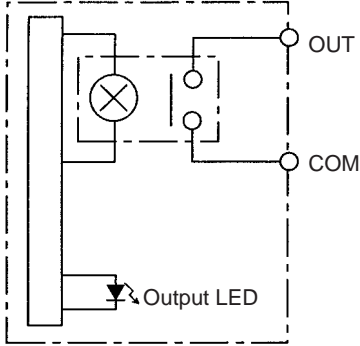
Item	Specification
Max. switching capacity	2 A, 250 V AC ($\cos\phi = 1$) 2 A, 24 V DC (4 A/common)
Min. switching capacity	10 mA, 5 V DC
Service life of relay (See note.)	Electrical: 150,000 operations (24-V DC resistive load) 100,000 operations (240-V AC inductive load, $\cos\phi = 0.4$) Mechanical: 20,000,000 operations
ON delay	15 ms max.
OFF delay	15 ms max.
Circuit configuration	

Note The service life of the CPM2B's relay output contacts shown in the table assumes the worst conditions. The following graph shows the results of OMRON's service life tests at a switching rate of 1,800 times/hour.

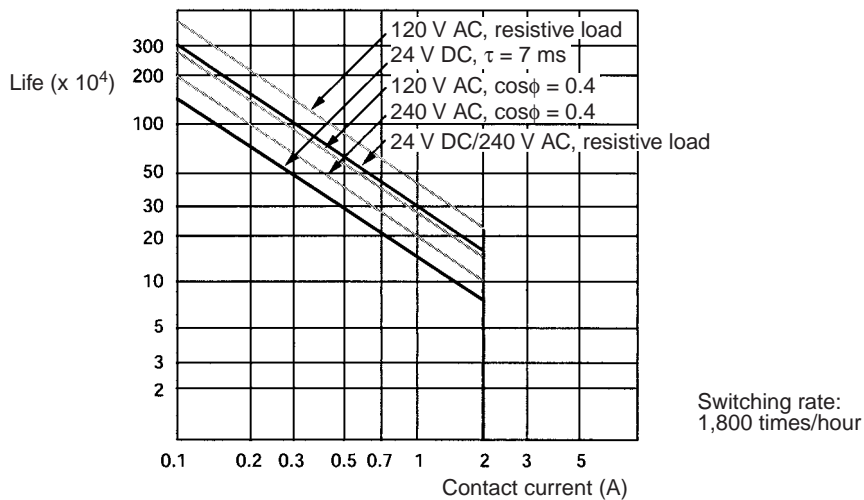

Transistor Outputs (Sinking or Sourcing)

Item	Specification
Max. switching capacity	OUT01000 and OUT01001: 4.5 to 30 V DC, 0.2 A/output (See note 1.) OUT01002 and up: 4.5 to 30 V DC, 0.3 A/output (See note 1.)
Leakage current	0.1 mA max.
Residual voltage	1.5 V max.
ON delay	OUT01000 and OUT01001: 20 μ s max. OUT01002 and up: 0.1 ms max.
OFF delay	OUT01000 and OUT01001: 40 μ s max. for 4.5 to 26.4 V, 10 to 100 mA 0.1 ms max. for 4.5 to 30 V, 10 to 200 mA OUT01002 and up: 1 ms max. for 4.5 to 30 V, 10 to 300 mA
Fuse	1 fuse/output (cannot be replaced by user)
Circuit configuration	<p>Sinking Outputs</p>

Note When using OUT01000 or OUT01001 for pulse outputs, connect a dummy resistor as required to bring the load current between 0.01 and 0.1 A. If the load current is below 0.01 A, the ON-to-OFF response time will be too long and high-speed pulses will not be output.

Caution Do not apply voltage in excess of the maximum switching capacity to an output terminal. It may result in damage to the product or fire.

Caution The maximum switching capacity (i.e., the total current for all ON circuits) of the output circuits of 64-point Expansion I/O Boards is limited by the mounting direction and ambient temperature. Use the following graphs to determine the connected loads under consideration of the mounting direction.

1,2,3... 1. Vertical Laying on the Side

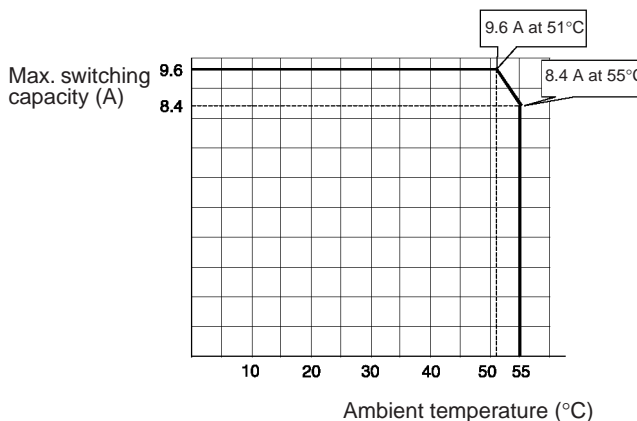

2. Vertical Standing Upright

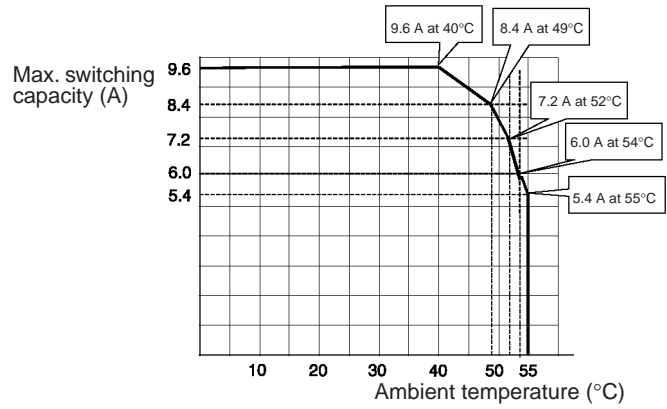

3. Horizontal

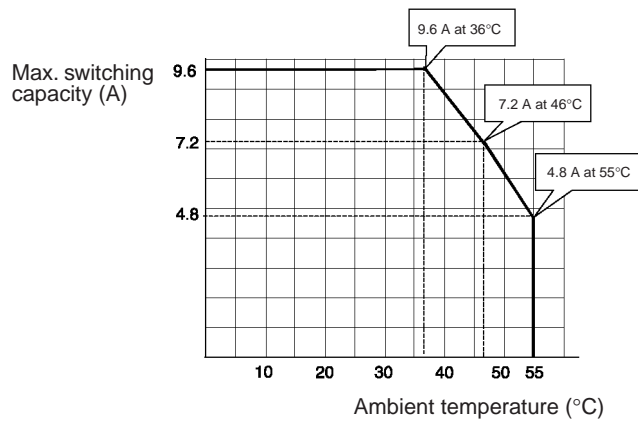

2-2 Board Components and their Functions

2-2-1 CPU Board Components

CPM2B-32C□DR-D 32-point CPU Boards with Relay Outputs

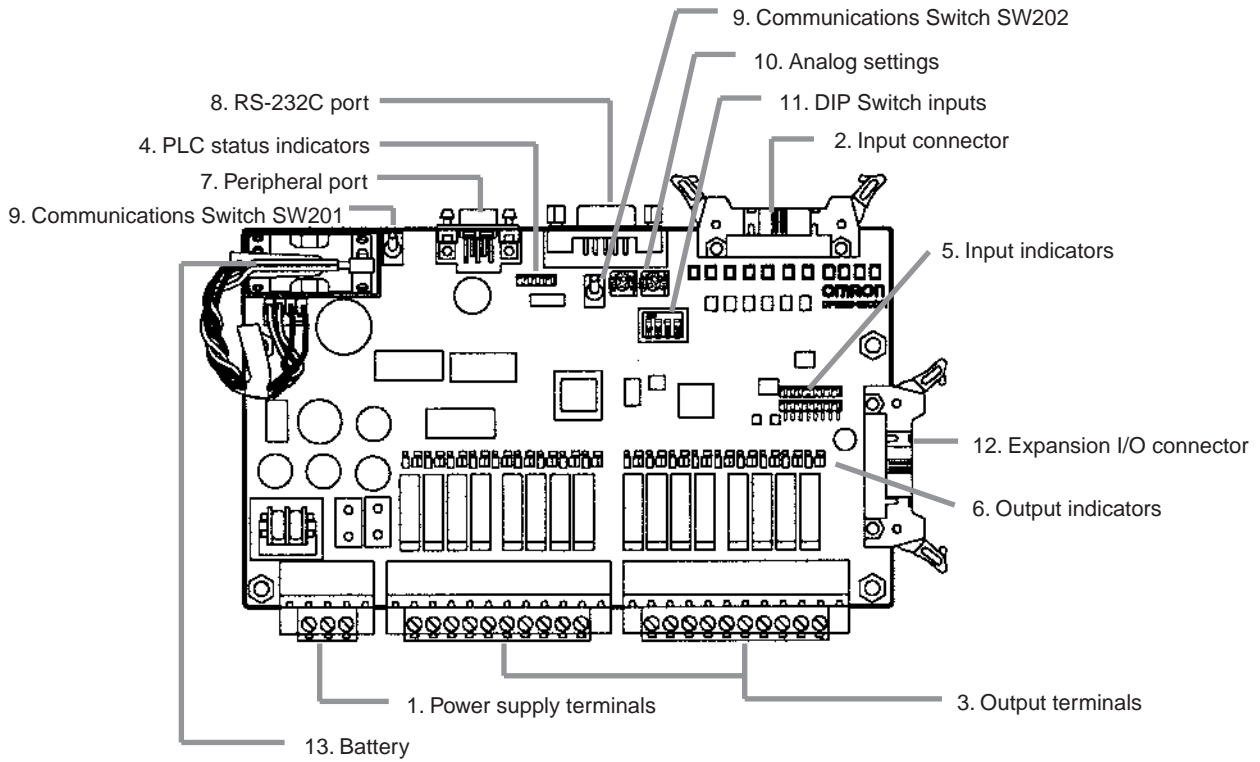

CPM2B-40C2DR-D 40-point CPU Boards with Relay Outputs

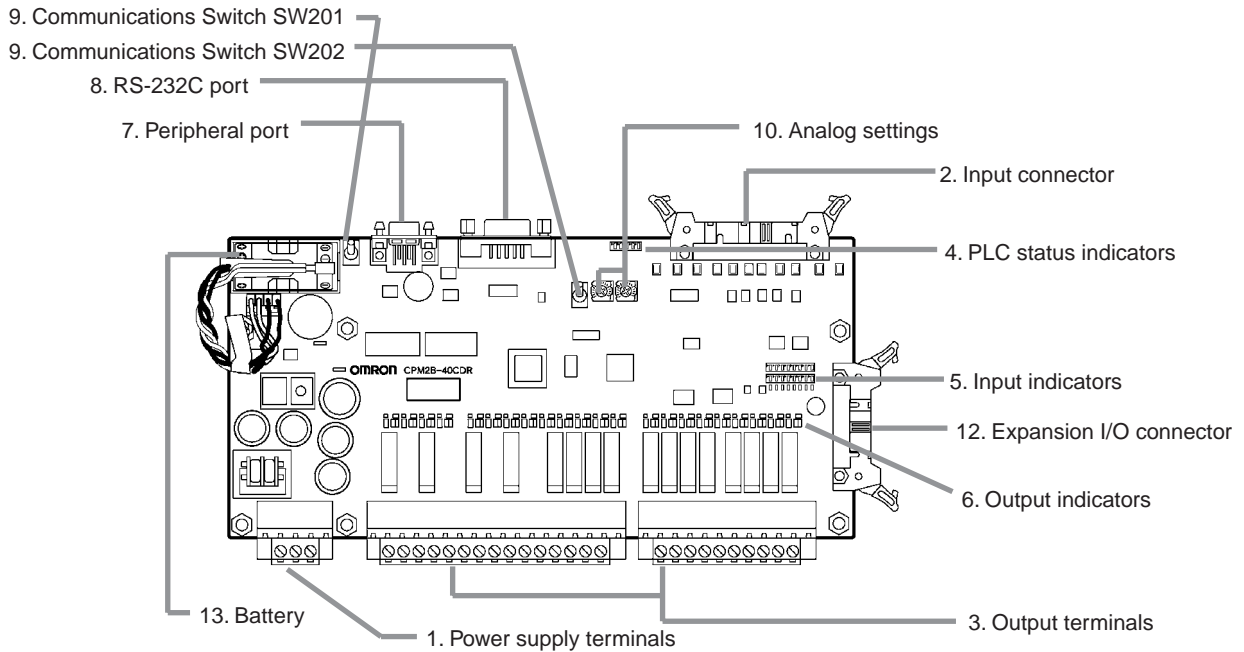

CPM2B-32C□DT-D, CPM2B-32C□DT1-D12 32-point CPU Boards with Transistor Outputs

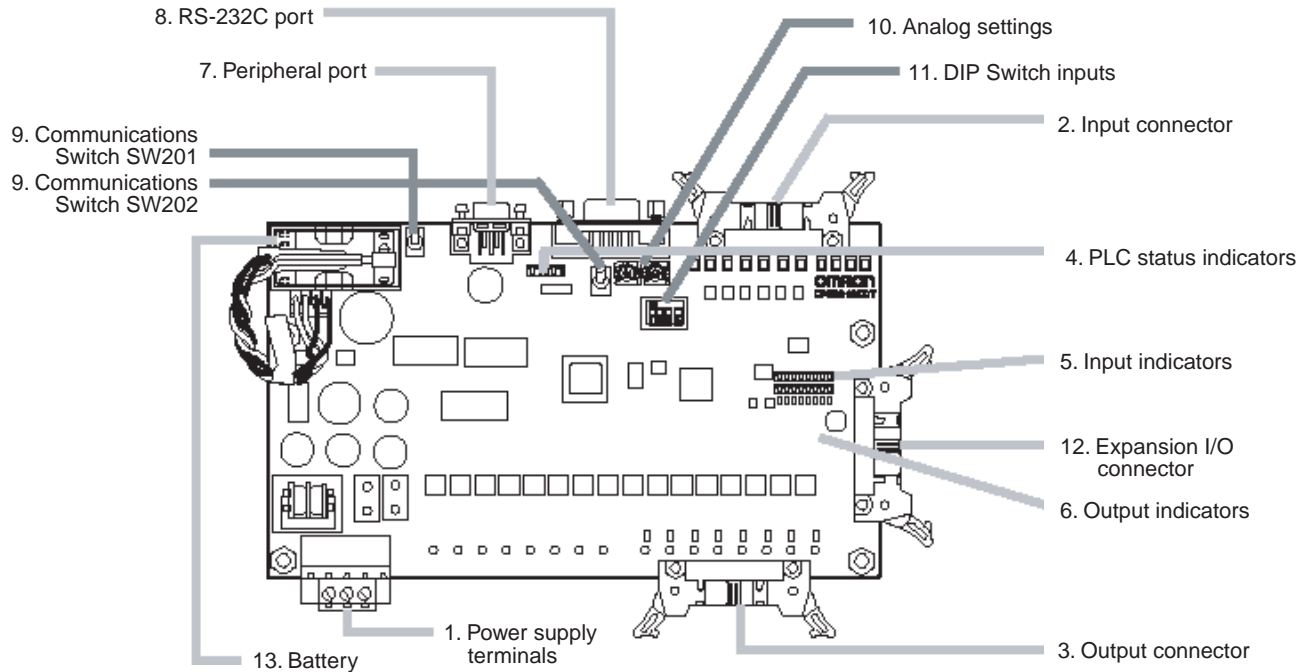

CPU Board Component Descriptions

1,2,3...

1. Power Supply Terminals
Connect the power supply (24 V DC or 12 V DC) to these terminals.
2. Input Connector
Connects the CPU Board to external input devices.
3. Output Terminals/Connector
Connects the CPU Board to external output devices.
4. PLC Status Indicators
These indicators show the operating status of the PLC, as shown in the following table.

Indicator	Status	Meaning
PWR (green)	Lit	Power is being supplied to the PLC.
	Not lit	Power isn't being supplied to the PLC.
RUN (green)	Lit	The PLC is operating in RUN or MONITOR mode.
	Not lit	The PLC is in PROGRAM mode or a fatal error has occurred.
ERR (red)	Lit	A fatal error has occurred. (PLC operation stops.)
	Flashing	A non-fatal error has occurred. (PLC operation continues.)
	Not lit	Indicates normal operation.
PERI (orange)	Flashing	Data is being transferred through the peripheral port.
	Not lit	The peripheral port is not in use.
COMM (orange)	Flashing	Data is being transferred through the RS-232C port.
	Not lit	The RS-232C port is not in use.

5. Input Indicators
The input indicators are lit when the corresponding input terminal is ON. The status of an input indicator will reflect the status of the input even when that input is being used for a high-speed counter.

Note a) When interrupt inputs are used in interrupt input mode, the indicator may not light even when the interrupt condition is met if the input is not ON long enough. When a high-speed counter is being used, the indicator may not light depending on the speed of the pulses.

b) Input indicators will reflect the status of the corresponding inputs even when the PLC is stopped, but the corresponding input bits will not be refreshed.

6. Output Indicators

The output indicators are lit when the corresponding output terminal is ON. The indicators are lit during I/O refreshing. When an output is being used as a pulse output, the corresponding will remain lit while pulses are being output.

7. Peripheral Port

Connects the PLC to a Programming Device (including Programming Consoles), host computer, or standard external device.

8. RS-232C Port

Connects the PLC to a Programming Device (excluding Programming Consoles), host computer, Programmable Terminal, or standard external device.

9. Communications Switches SW201 and SW202

The Communications Switches control the communications settings for the peripheral port and RS-232C port.

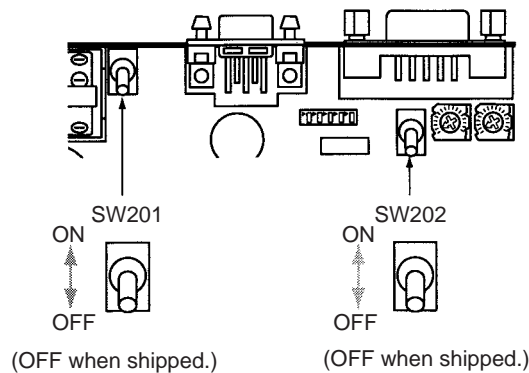

Switch settings		Peripheral port communications	RS-232C port communications
SW202	SW201		
OFF	OFF	Programming Console connection	The settings in the PLC Setup (DM 6645 to DM 6649) are used.
OFF	ON	Other Programming Device: The settings in the PLC Setup (DM 6650 to DM 6654) are used.	
ON	OFF	Programming Console connection	The standard settings are used.
ON	ON	Other Programming Device: The standard settings are used.	

Note a) The standard settings are 1 start bit, 7 data bits, 2 stop bits, even parity, and 9,600 bps baud rate.

b) Be sure that Communications Switch SW201 is OFF when connecting a Programming Console.

10. Analog Settings

Turning these controls changes the contents of IR 250 and IR 251. The contents of these words can be set independently between 0 and 200.

11. DIP Switch Inputs

The ON/OFF status of IR 00108 through IR 00111 reflects the ON/OFF status of these DIP switch pins.

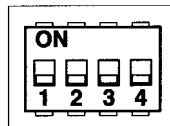

Pin	Corresponding input bit
	32-point CPU Board
1	IR 00108
2	IR 00109
3	IR 00110
4	IR 00111

12. Expansion I/O Connector

Connects the CPU Board to an Expansion I/O Board. Up to 3 Expansion I/O Boards can be connected to a CPU Board.

13. Battery

This battery backs up memory in CPU Boards equipped with an internal clock. The battery is connected when the Unit is shipped.

2-2-2 Expansion I/O Boards

CPM2B-32EDR 32-point Expansion I/O Boards with Relay Outputs

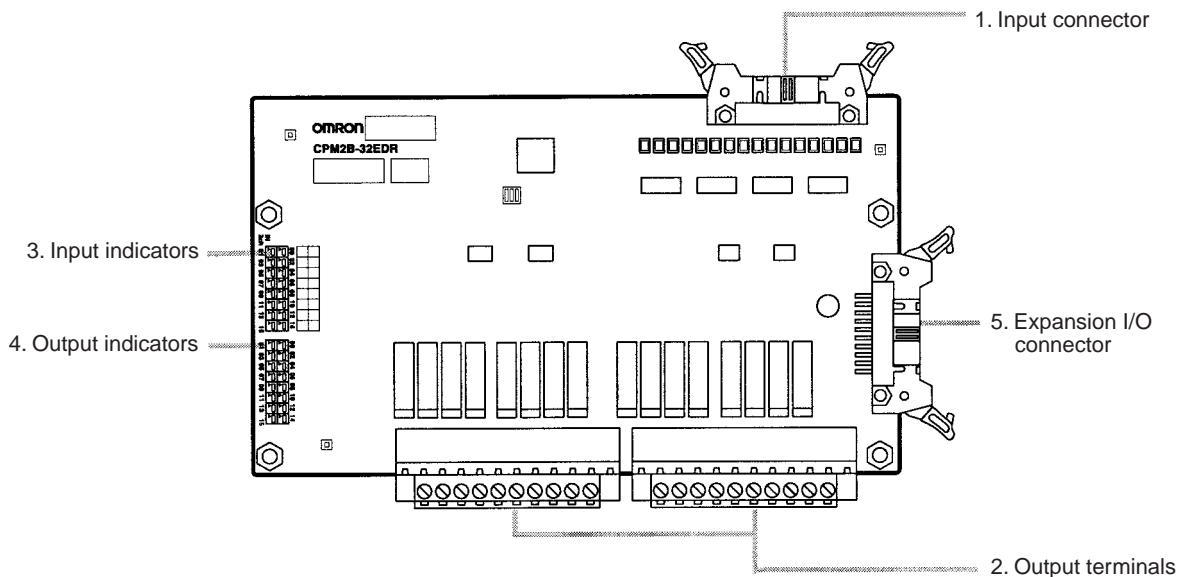

CPM2B-40EDR 40-point Expansion I/O Boards with Relay Outputs

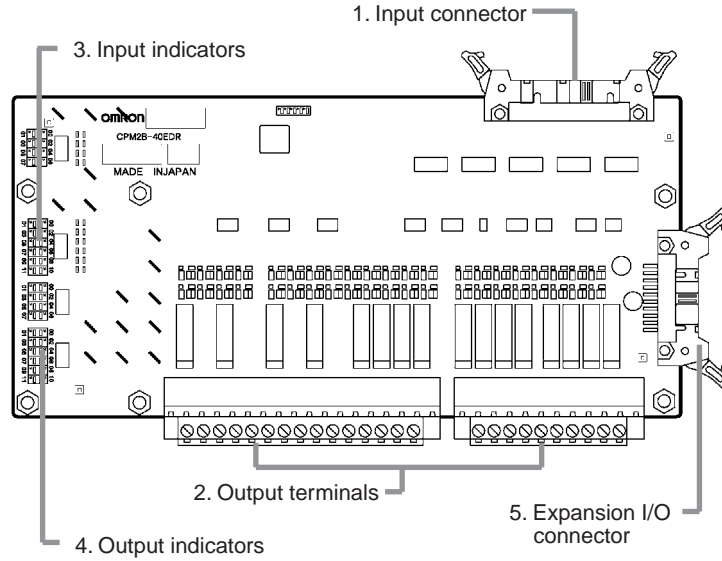

CPM2B-32EDT, CPM2B-32ED1T 32-point Expansion I/O Boards with Transistor Outputs

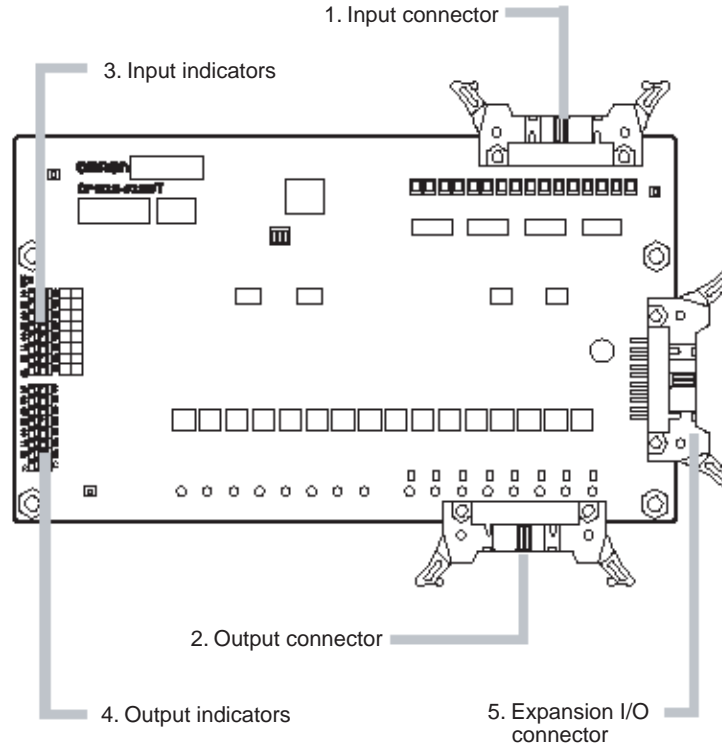

CPM2B-64EDT 64-point Expansion I/O Boards with Transistor Outputs

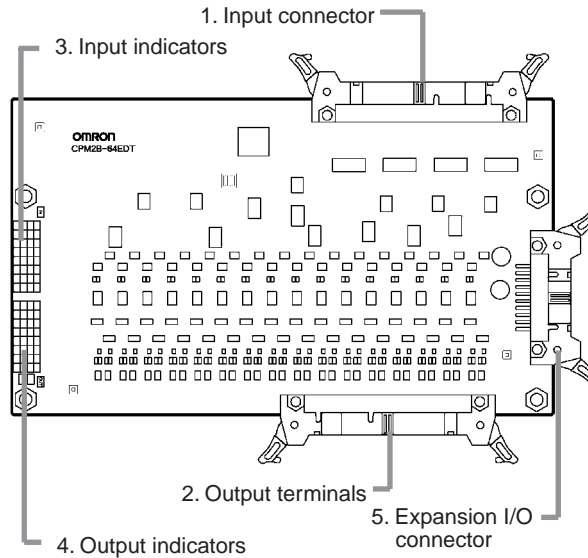

1,2,3...

1. Input Connector

Connects the Expansion I/O Board to external input devices.

2. Output Terminals/Connector

Connects the Expansion I/O Board to external output devices.

3. Input Indicators

The input indicators are lit when the corresponding input terminal is ON.

4. Output Indicators

The output indicators are lit when the corresponding output terminal is ON.

5. Expansion I/O Connector

Connects the Expansion I/O Board to the CPU Board or the previous Expansion Unit or Expansion I/O Unit. Up to 3 Expansion I/O Boards can be connected to a CPU Board (unless 64-point Expansion I/O Boards are used, in which case only up to 2 Boards can be connected). An Expansion I/O Cable is included with each Expansion I/O Board.

Note Do not touch the cables during operation to prevent unexpected operation due to static discharge.

2-3 I/O Connector and Terminal Pin Allocation

32-point CPU Boards

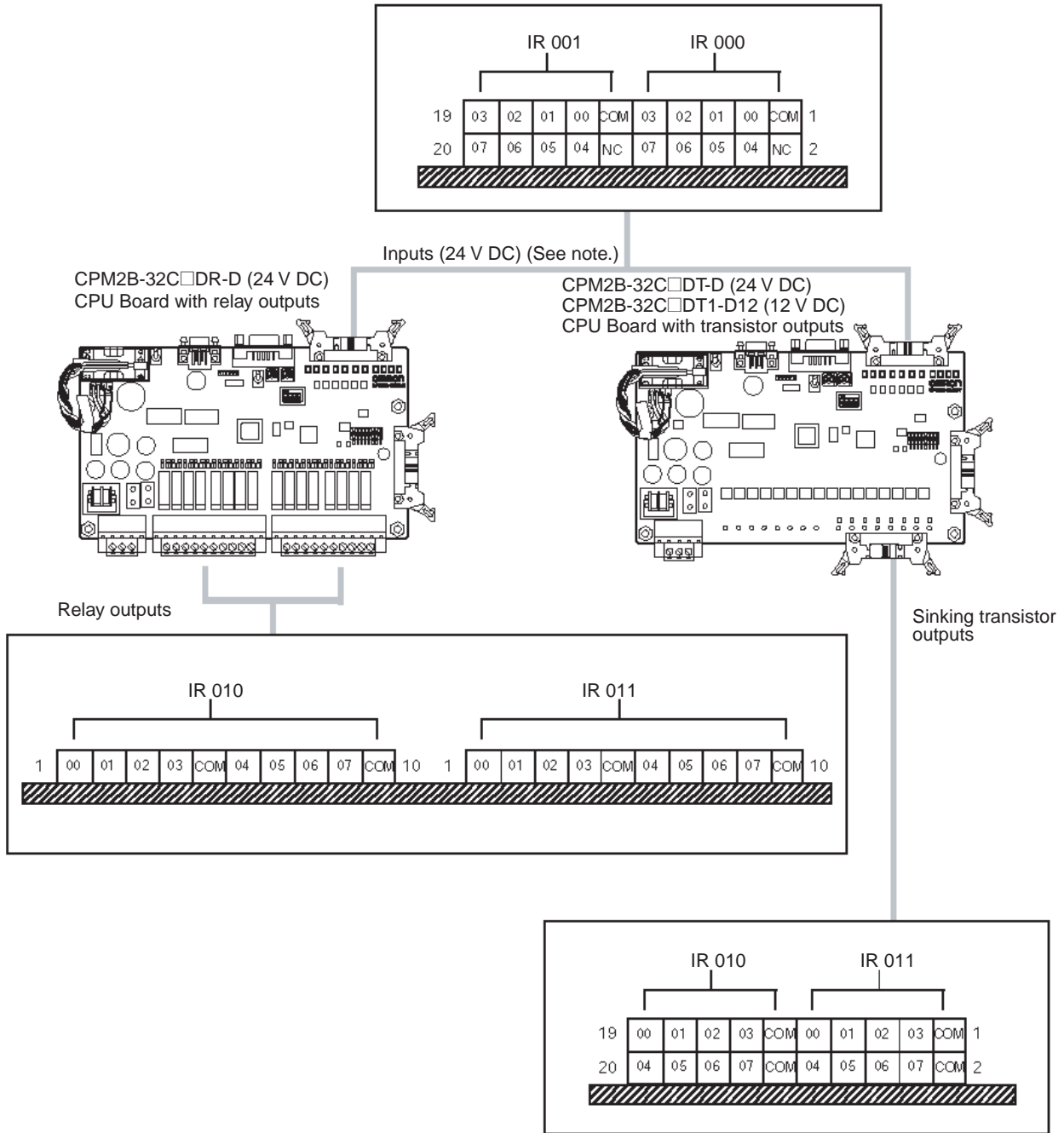

Note Inputs for the CPM2B-32C□DT1-D12 are 12 V DC.

40-point CPU Boards

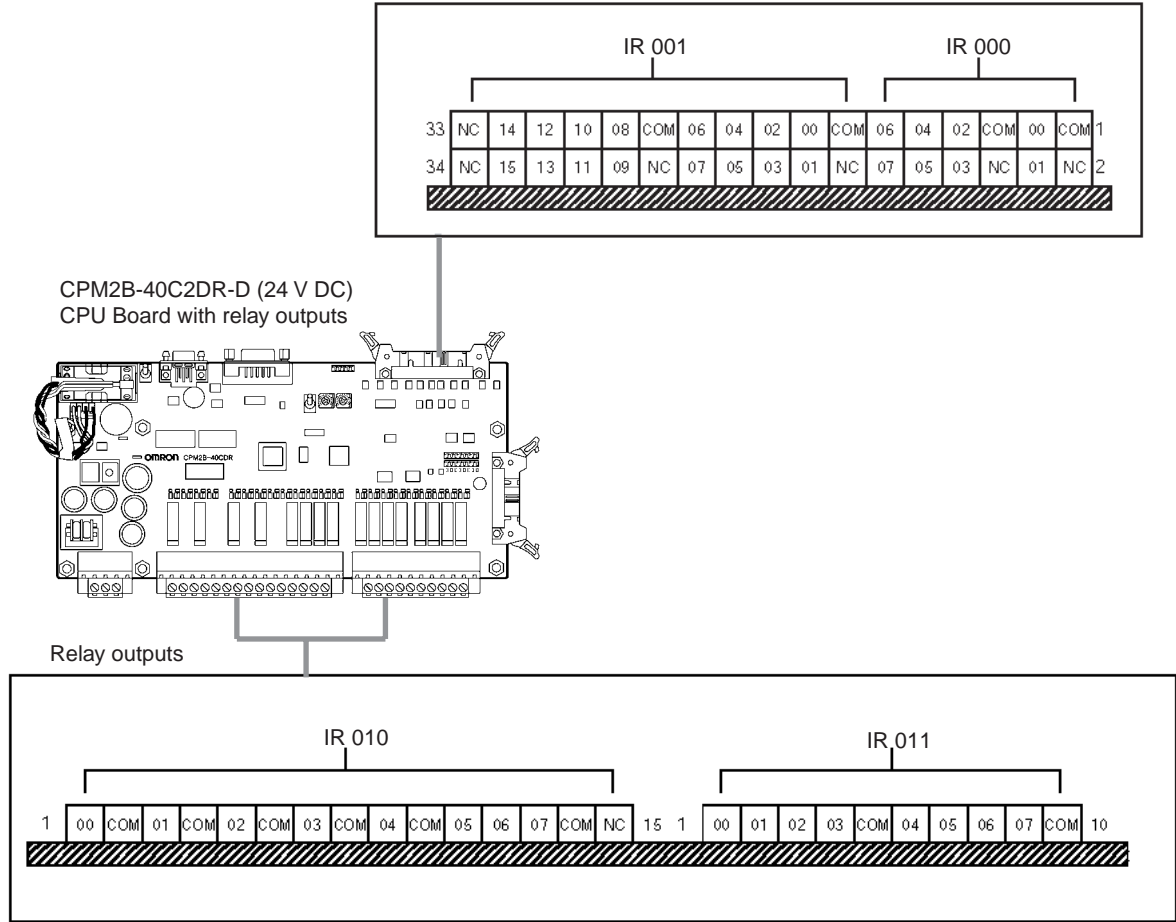

32-point Expansion I/O Boards

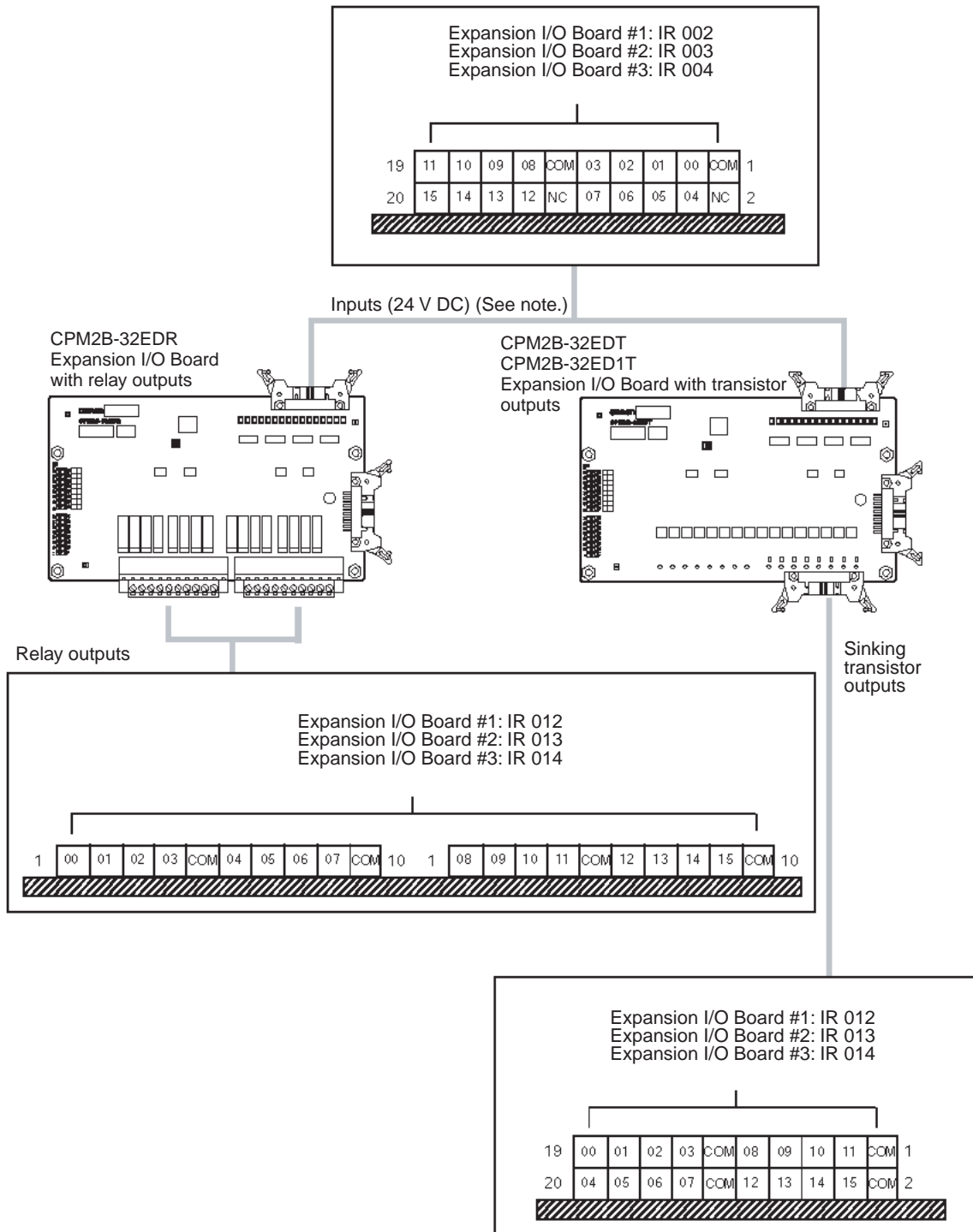

Note Inputs for the CPM2B-32ED1T are 12 V DC.

CPM2B-40EDR 40-point Expansion I/O Boards

Expansion I/O Board with relay outputs

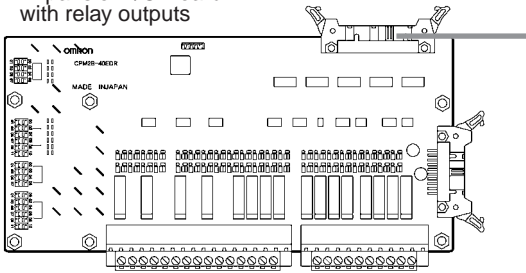

Inputs (24 V DC)

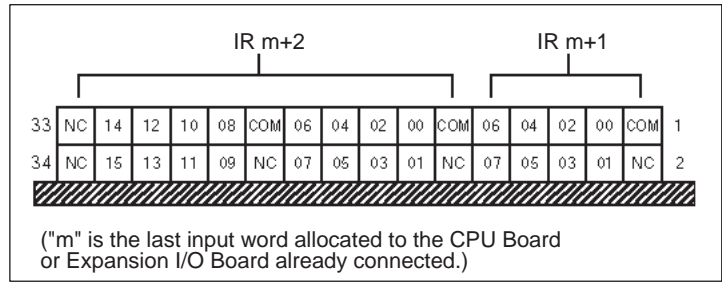

Relay outputs

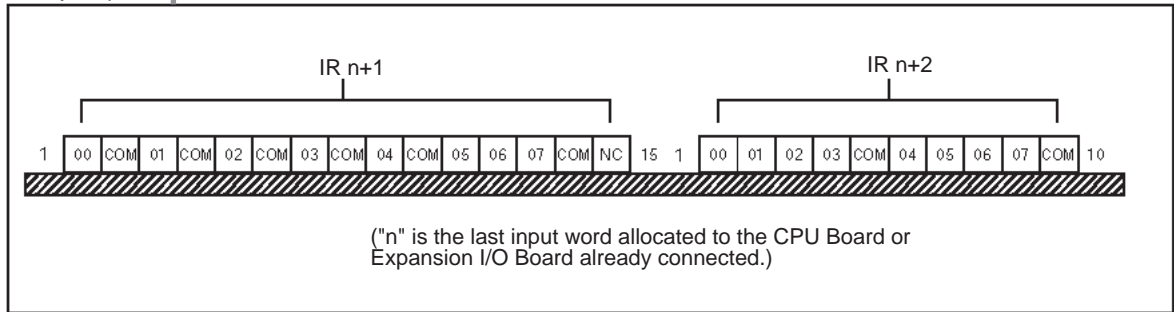

CPM2B-64EDT 64-point Expansion I/O Boards

Transistor outputs

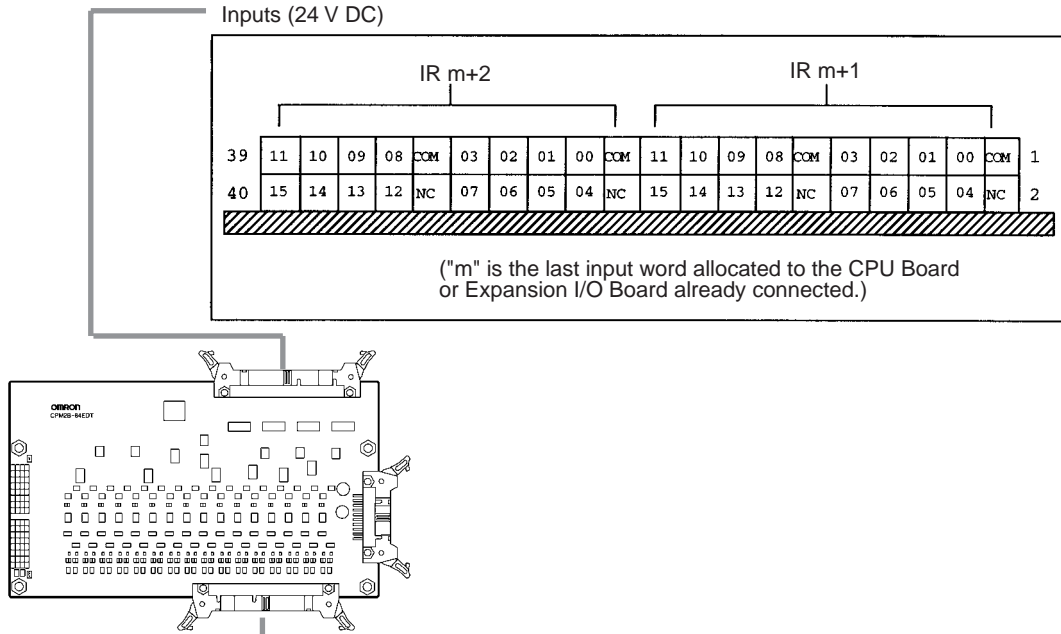

Transistor outputs (sinking)

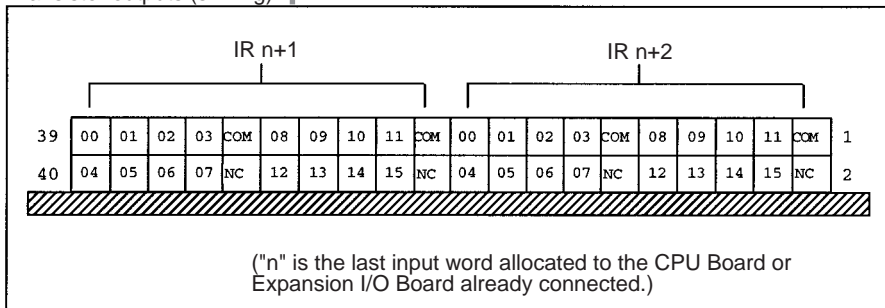

SECTION 3

Installation and Wiring

This section provides information on installing and wiring a CPM2B PLC. Be sure to follow the directions and precautions in this section when installing the CPM2B in a panel or cabinet, wiring the power supply, or wiring I/O.

3-1	Design Precautions	46
3-1-1	Power Supply Wiring	46
3-1-2	Power Supply Voltage	46
3-1-3	Interlock and Limit Circuits	46
3-1-4	Number of Expansion Boards	47
3-2	Selecting an Installation Site	47
3-2-1	Installation Site Conditions	47
3-2-2	Panel/Cabinet Installation	48
3-3	Assembling the CPM2B Boards	48
3-4	Installing the CPM2B	51
3-5	Wiring and Connections	51
3-5-1	Power Supply Wiring	52
3-5-2	I/O Wiring Procedures	53
3-5-3	Connecting Input Devices	57
3-5-4	Output Wiring	63

3-1 Design Precautions

Observe the following precautions when designing a system incorporating a CPM2B PLC.

3-1-1 Power Supply Wiring

Separate the power supply wiring from the power system, control system, CPM2B system, and DC I/O system wiring. Separate the control circuits that supply power to the main Unit from the main circuits using dedicated circuit protectors and fuses.

3-1-2 Power Supply Voltage

Caution Use the power supply voltages indicated in *Section 2-1 Specifications*. Failure to adhere to the specifications may result in fire.

If the power supply voltage falls below 85% of the rated voltage, the CPM2B will stop and all outputs will be turned OFF. If low voltage affects the equipment, etc., provide a protection circuit which shuts off the output until the supply voltage returns to the rated value.

In places where power supply conditions are poor, take steps to ensure that power is supplied at the rated voltage. Be sure to adhere to safety precautions, such as providing breakers to prevent short circuits in external wiring. When conducting any of the following operations, turn OFF the power to the PLC. Electrocution, product damage and malfunction may result.

- Connecting or disconnecting Expansion I/O Boards and CPU Boards.
- Assembling equipment.
- Connecting cables and wiring.

3-1-3 Interlock and Limit Circuits

WARNING Emergency stop circuits, interlock circuits, limit circuits, and similar safety measures must be provided in external control circuits (i.e., not in the Programmable Controller) to ensure safety in the system if an abnormality occurs due to malfunction of the PLC or another external factor affecting the PLC operation. Not providing proper safety measures may result in serious accidents.

The following diagram shows an example of an interlock circuit.

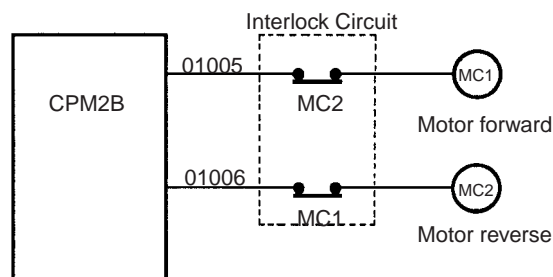

In the interlock circuit above, MC1 and MC2 can't be ON at the same time even if CPM2B outputs 01005 and 01006 are both ON (an incorrect PLC operation).

3-1-4 Number of Expansion Boards

CPU Boards can be combined with Expansion I/O Boards or Analog I/O Boards, but are subject to the following restrictions.

1,2,3...

1. Number of Boards:
Up to a total of three Boards can be connected, including Expansion Boards and Analog I/O Boards.
2. The supported Board combinations according to power supply are as follows:

CPU Board power supply	Expansion I/O Boards		Analog I/O Boards
	24-V DC input	12-V DC input	
24 V DC	Supported	Supported	Supported
12 V DC	Not supported	Supported	Not supported

3. I/O Words Restrictions:
The number of I/O words allocated in the CPM2B as input words for the CPU Board, Expansion I/O Board, and Analog I/O Board must not exceed the IR Area input words from IR 000 to IR 009. The words allocated as output words must not exceed the IR Area output words from IR 010 to IR 019. For example, the CPU Board is already allocated two input words and two output words, so a total of eight words each are available for allocation to the Expansion Boards that can be connected.

3-2 Selecting an Installation Site

The CPM2B is resistant to harsh conditions and highly reliable, but installing the PLC in a favorable site will maximize its reliability and operating lifetime.

 **Caution** Be sure to install the CPM2B correctly, as outlined in this manual. Failure to do so may result in Board malfunction.

3-2-1 Installation Site Conditions

Note Do not install the CPM2B under any of the following conditions.

- Locations subject to direct sunlight.
- Locations subject to an ambient temperature below 0°C or over 55°C.
- Locations subject to an ambient humidity below 10% or over 90%.
- Locations subject to condensation as the result of severe changes in temperature.
- Locations subject to corrosive or flammable gases.
- Locations subject to dust (especially iron dust) or salts.
- Locations subject to shock or vibration.
- Locations subject to exposure to water, oil, or chemicals.

Be sure that the conditions at the installation site conform to the CPM2B's general specifications. Refer to 2-1-1 *General Specifications* for details.

Note Provide proper shielding when installing in the following locations:

- Locations subject to static electricity or other sources of noise.
- Locations subject to strong electromagnetic fields.
- Locations subject to possible exposure to radiation.

- Locations near to power supply lines.

3-2-2 Panel/Cabinet Installation

Consider PLC operation, maintenance, and surrounding conditions when installing the CPM2B in a panel or cabinet.

Overheating

The ambient operating temperature range for the CPM2B is 0°C to 55°C. Be sure that there is adequate ventilation for cooling.

- Allow enough space for air circulation.
- Do not install the CPM2B above equipment that generates a large amount of heat, such as heaters, transformers, or large resistors.
- Install a cooling fan or system when the ambient temperature exceeds 55°C.

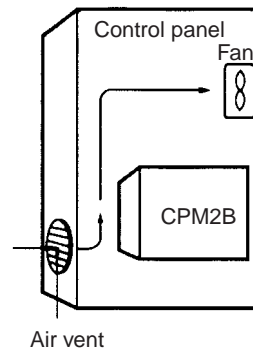

Electrical noise

Power lines and high-voltage equipment can cause electrical noise in the PLC.

- Do not install the CPM2B in a panel or cabinet with high-voltage equipment.
- Allow at least 200 mm between the CPM2B and nearby power lines.

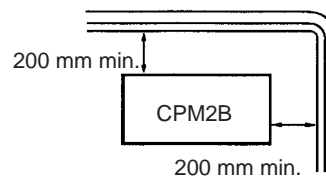

Accessibility

Ensure that the CPM2B can be accessed for normal operation and maintenance. High-voltage equipment, power lines, and moving machinery could be dangerous if they are in the way during routine operations.

3-3 Assembling the CPM2B Boards



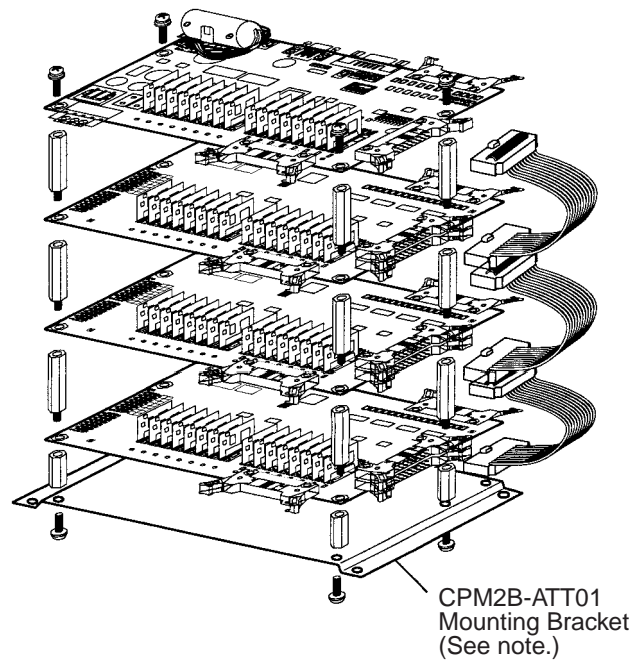

Board Assembly

Up to 3 Expansion I/O Boards can be connected to a CPM2B CPU Board. The following diagram shows how to assemble the Boards. The screws and standoffs are included with the CPU Board, Expansion I/O Board, and Mounting Bracket.

Note Use M3 screws for the standoffs and tighten to a torque of 0.5 N•m.

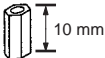

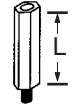
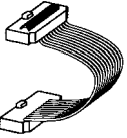
Note The CPM2B-ATT01 Mounting Bracket is required when the system must meet UL/CSA standards.

Board or Bracket	Hardware and cables included			
CPU Board	Four M3 standoffs (short)			
	Four M3 screws			
Expansion I/O Board	Four M3 standoffs (long)			
	Boards		L	
	32-point models		Expansion I/O Board (24 V DC)	26 mm
	32-point models		Expansion I/O Board (12 V DC)	22 mm
	40/60-point models		Expansion I/O Board (24 V DC)	
One CPM2B-CN601 Expansion I/O Cable (Cable length = 60 mm)				
Mounting Bracket	Four M3 screws			

Note Some of the CPM2B's electrical components such as leads are sharp, so do not touch the components or the surface of the circuit board.

Installing the Expansion I/O Connecting Cables

- 1,2,3...** 1. Insert the Expansion I/O Cable into the connectors on the CPU Board and Expansion I/O Board.

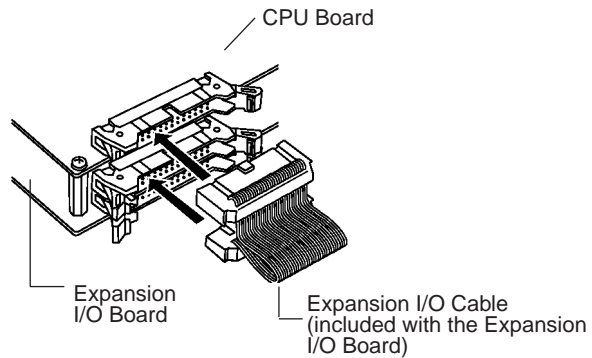

The cable from the CPU Board connects to the upper Expansion I/O Connector (the one with the short locks.)

Install the shorter connector of the cable in the lower Board and the longer connector in the upper Board.

2. Push the cable's connector into the Board's connector until both lock levers lock solidly.

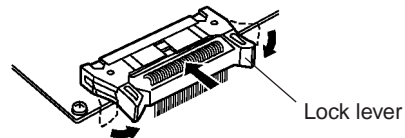

To remove the Expansion I/O Cable, open the connectors lock levers and pull out the cable's connector.

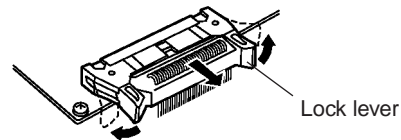

3-4 Installing the CPM2B

Install the CPM2B as shown in the following diagram. The CPM2B cannot be installed on DIN Track.

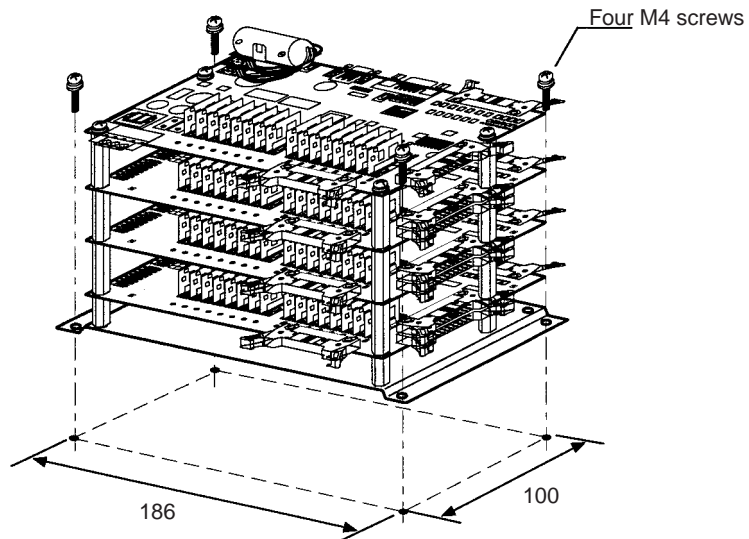

Example Installations

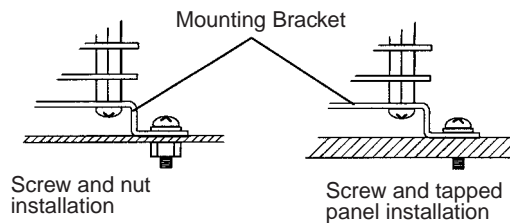

- Note**
1. Use M4 screws and tighten to a torque of 1.2 N•m.
 2. The CPM2B can be installed without a CPM2B-ATT01 Mounting Bracket, but the Mounting Bracket must be used to conform to UL/CSA standards. Refer to *Appendix B* for mounting dimensions.
 3. Installing the CPM2B horizontally or with its narrow edge down affects cooling and limits the number of inputs or outputs that can be ON simultaneously at high temperatures. Refer to pages 28 and 32 for details.

3-5 Wiring and Connections

This section provides basic information on power supply wiring and I/O wiring.

General Precautions for Wiring

- ⚠ Caution** Cover the CPM2B Boards with plastic or use some other method to prevent strands of wire from getting on the Board or inside the Board's components during wiring. Wire strands may short circuit the Board's components.

I/O Line Noise

Do not run CPM2B I/O lines in the same duct or conduit as power lines.

Hanging Ducts

Leave at least 300 mm between the power cables and the I/O or control wiring, as shown in the following diagram.

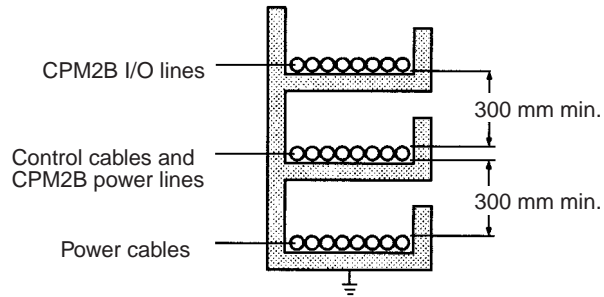

Floor Ducts

Leave at least 200 mm between the wiring and the top of the duct, as shown in the following diagram.

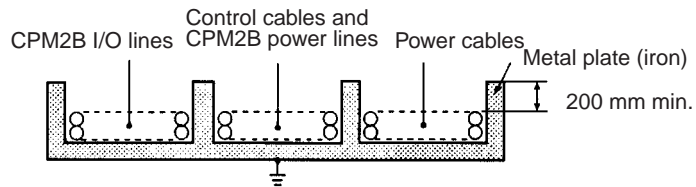

Conduits

Separate the CPM2B I/O lines, power and control lines, and power cables, as shown in the following diagram.

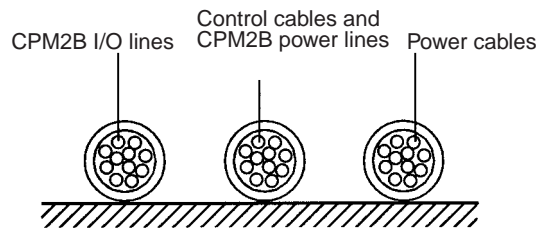

3-5-1 Power Supply Wiring

The power supply terminal specifications are shown below. Supply the power supply terminals with either 24 V DC or 12 V DC.

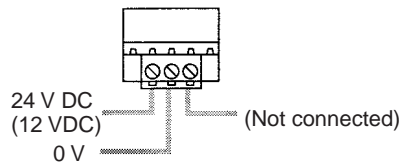

Terminal Specifications

Item	Specifications
Screw size	M3
Recommended torque	0.5 to 0.6 N•m Recommended screwdriver: OMRON XW4E-00C

Compatible Wires and Terminals

Wire/terminal		Specification
Solid wire		0.2 to 2.5 mm ² (AWG 24 to AWG 12) Strip 7 mm (1/4 inch) of insulation.
Stranded wire		0.2 to 2.5 mm ² (AWG 24 to AWG 12) Strip 7 mm (1/4 inch) of insulation.
Two-conductor wires	Solid	2 × (0.2 to 1.0 mm ²) (AWG 24 to AWG 20)
	Stranded	2 × (0.2 to 1.5 mm ²) (AWG 24 to AWG 16)
	Stranded with pin terminal	2 × (0.25 to 1.0 mm ²) (AWG 24 to AWG 20) without an insulating sleeve
Pin terminals		0.2 to 2.5 mm ² diameter, 7-mm long pin terminal

The following diagram shows how to wire the power supply.

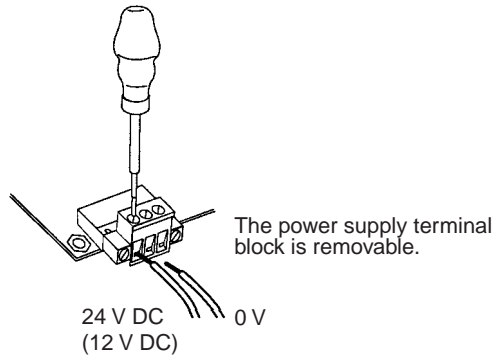

- Note**
1. Do not perform a voltage withstand test on the DC power supply terminals. The test might damage the PLC's internal components.
 2. When equipment must conform to the EC Directives (Low-voltage Directives), use a power supply with double insulation or reinforced insulation.

3-5-2 I/O Wiring Procedures

Removing and Wiring I/O Terminal Blocks

The following tables provide output terminal block specifications.

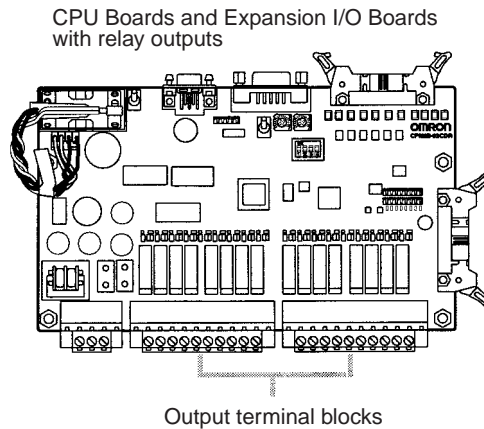

Terminal Block Specifications

Item	Specification
Screw size	M3
Recommended tightening torque	0.5 to 0.6 N•m Recommended screwdriver: OMRON XW4E-00C

Recommended Wire and Terminals

Item	Specification	
Solid wire	0.2 to 2.5 mm ² (AWG 24 to AWG12) (Strip 7 mm.)	
Stranded wire (See notes.)	0.2 to 2.5 mm ² (AWG 24 to AWG12) (Strip 7 mm.)	
Two-conductor wires	Solid	2 × (0.2 to 1.0 mm ²) (AWG 24 to AWG 20)
	Stranded	2 × (0.2 to 1.5 mm ²) (AWG 24 to AWG 16)
	Stranded with pin terminal	2 × (0.25 to 1.0 mm ²) (AWG 24 to AWG 20) without an insulating sleeve
Pin terminals	0.2 to 2.5 mm ² diameter, 7-mm long pin terminal	
Bridge (shorts terminals)	Terminal pitch 5.08 mm Recommended Bridges: OMRON XW4Z-02C (2 pole) OMRON XW4Z-03C (3 pole)	

- Note**
1. When using stranded wire, be sure to avoid stray wire strands that might short-circuit an adjacent terminal.
 2. Do not solder the ends of stranded wires. Solder can break and cause wiring problems. Also, the solder can cause corrosion on the contact surface.
 3. Be sure to use the correct pin allocation when assembling and wiring connectors or terminal blocks.

Removing and Wiring a Terminal Block

Use the following procedure when wiring a terminal block.

- 1,2,3...
1. Use a flatblade screwdriver to loosen the screws at the left and right sides of the terminal block.

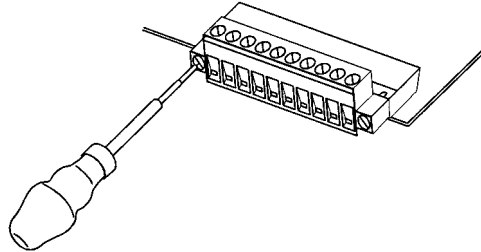

2. Pull the terminal block out of the Board.

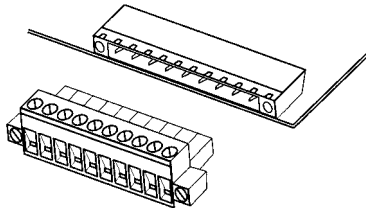

3. Insert each lead wire into the terminal block and tighten that terminal's screw.

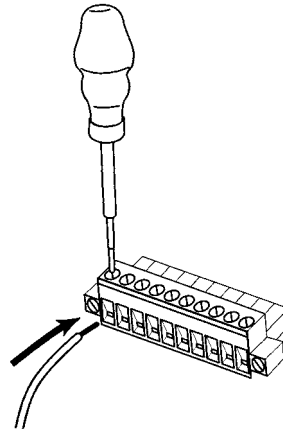

4. After wiring the terminal block, insert the block into the Unit and tighten the screws at the left and right sides of the terminal block.

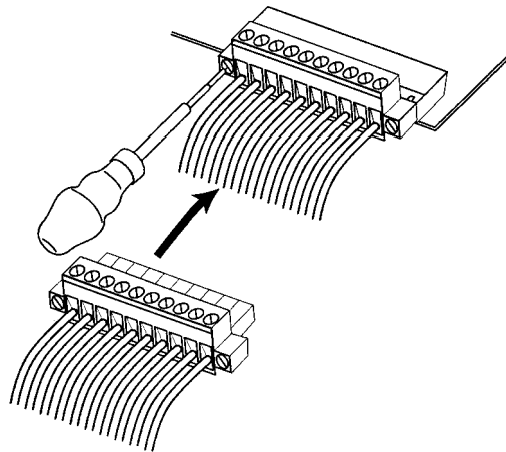

Removing and Wiring I/O Connectors

The following tables provide specifications of compatible OMRON I/O connectors.

MIL Flat Cable Connector

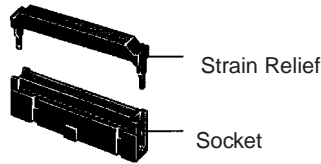

Note The max. rated current for flat cable is 1 A. Be sure that the current at the common terminal does not exceed 1A.

Available Models

Name	32-point CPU Boards and Expansion I/O Boards	40-point CPU Boards and Expansion I/O Boards	64-point Expansion I/O Boards
Socket	XG4M-2030	XG4M-3430	XG4M-4030
Strain Relief	XG4T-2004	XG4T-3404	XG4T-4004
Set (Socket + Strain Relief)	XG4T-2030-T	XG4M-3430-T	XG4M-4030T
Recommended Flat Cable	XY3A-200□	Not available	Not available

OMRON Crimping Tools

Crimping Tool	XY2B-0002
Attachment	XY2B-1007

MIL Loose-wire Pressure Connector

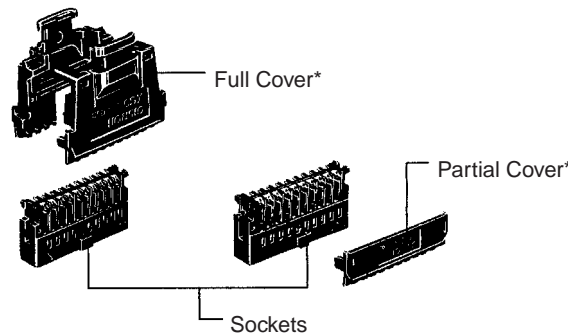

Note Two Full Covers or Partial Covers are required for each socket.

Available Models

Name		32-point CPU Boards and Expansion I/O Boards	40-point CPU Boards and Expansion I/O Boards	64-point Expansion I/O Boards
Socket	AWG 24	XG5M-2032-N	XG5M-3432-N	XG5M-4032-N
	AWG 26 to 28	XG5M-2035-N	XG5M-3435-N	XG5M-4035-N
Full Cover (2 required for each Socket)		XG5S-2012	XG5S-3412	XG5S-4012
Partial Cover (2 required for each Socket)		XG5S-1001	XG5S-1701	XG5S-2001

OMRON Pressing Tools

Pressing Tool Set (Handy Press)	XY2B-2104
Simple Pressing Tool	XY2B-7006

Using Relay Terminal and Terminal Blocks

A G79-A□C (Loose-wire Connecting Cable) can be used to connect to a Relay Terminal. (A pressure connector must be attached on the PLC side of the cable.)

A special cable is not provided for connection to the XW2B-20G4 or XW2B-20G5 Terminal Blocks, so one must be made. (The Terminal Block requires the kind of MIL 20P connector described above.)

Inserting and Removing I/O Connectors

When inserting a cable, first open the lock levers on each side of the connector and then insert the cable's connector. Press the cable's connector firmly until both lock levers lock onto the connector.

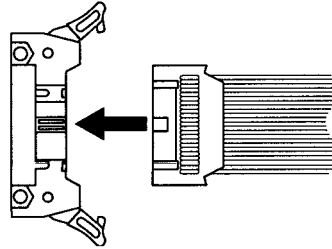

To remove the cable, open the lock levers to the left and right before removing the cable's connector.

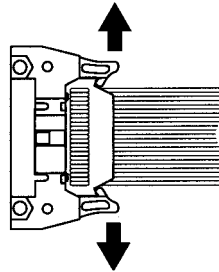
**3-5-3 Connecting Input Devices**

Wire inputs to the CPM2B CPU Board and Expansion I/O Boards as shown in the following diagrams.

Note When equipment must conform to the EC Directives (Low-voltage Directives), use a power supply with double insulation or reinforced insulation.

CPU Boards

Input Connector

CPM2B-32C□DR-D
 CPM2B-32C□DT-D
 CPM2B-32C□DT1-D12

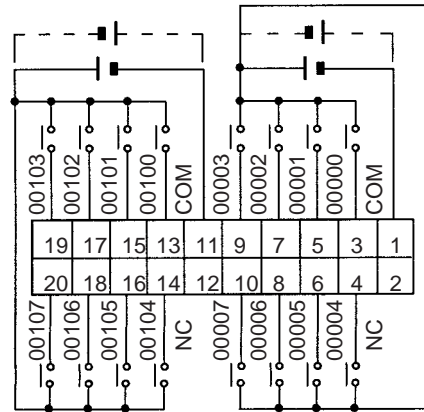

Input Connector

CPM2B-40C2DR-D

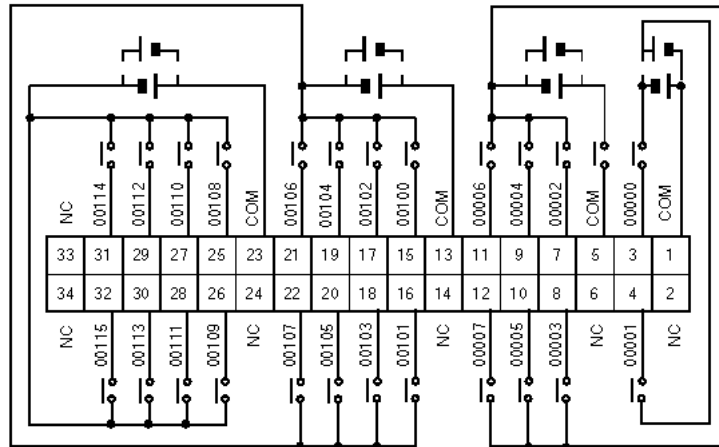

Expansion I/O Boards

CPM2B-32EDR
CPM2B-32EDT/32ED1T

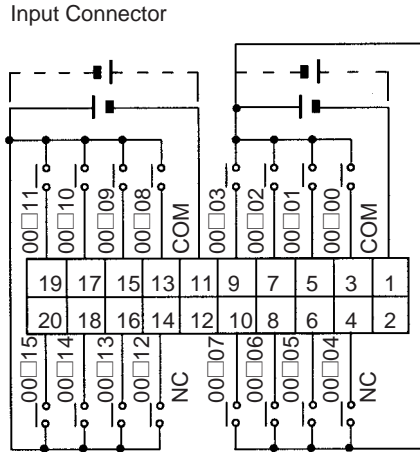

CPM2B-40EDR

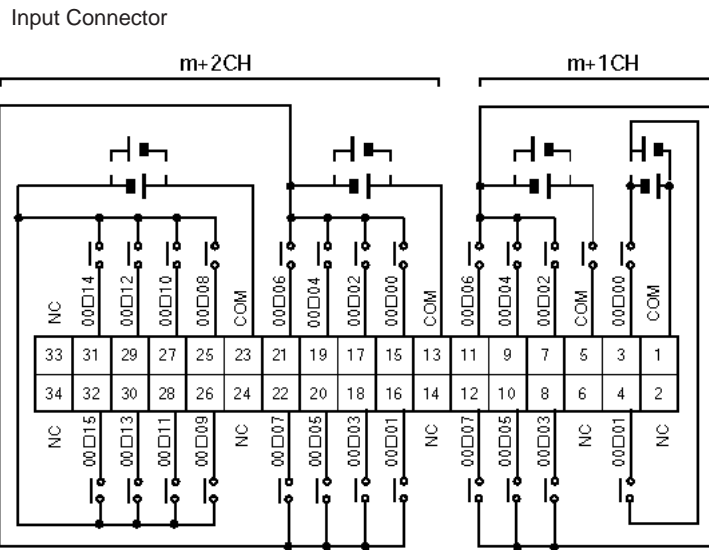

CPM2B-64EDT

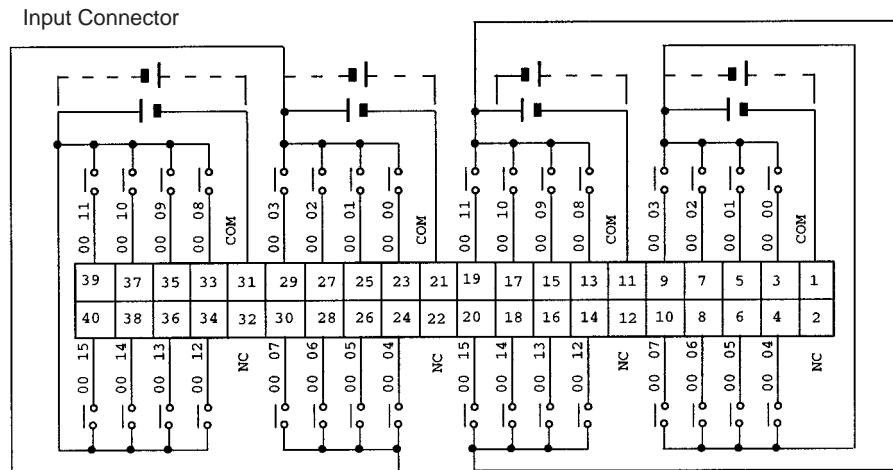

Input Devices

The following table shows how to connect various input devices.

Device	Circuit diagram
Relay output	
NPN open collector	
NPN current output	
PNP current output	
Voltage output	

Note Do not use the following wiring with voltage-output devices:

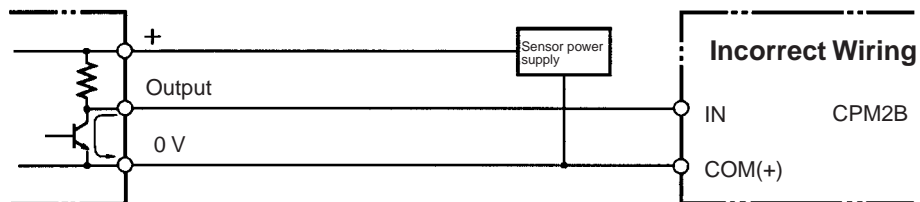

High-speed Counter Inputs

Using IR 00000 to IR 00002 as High-speed Counter Inputs

In these examples, Encoders with an external 24-V DC open-collector output are connected.

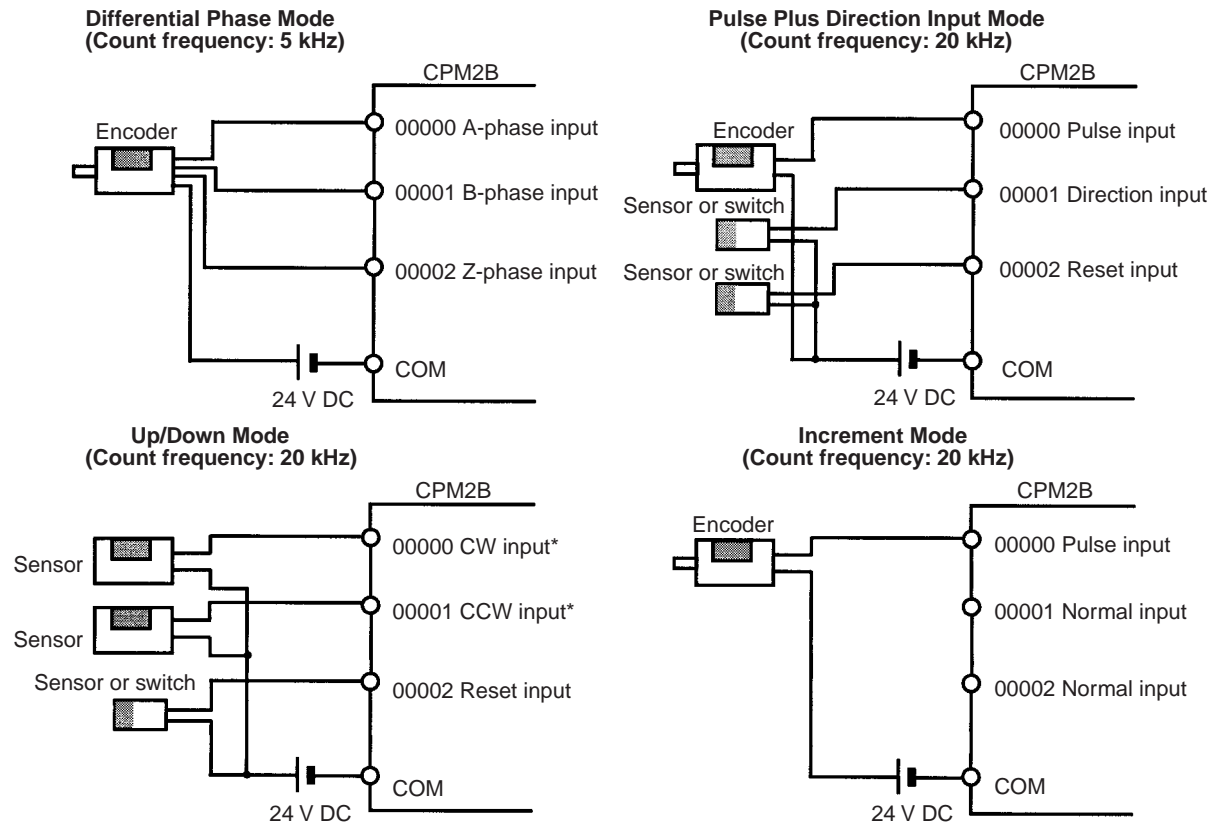

Note *CW is clockwise and CCW is counter-clockwise.

Using IR 00003 to IR 00006 as Interrupt Inputs (Counter Mode)

In these examples, an Encoder with an external 24-V DC open-collector output is connected.

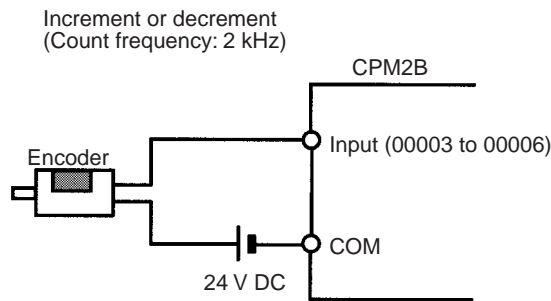

PLC Setup Settings

The input bits shown in the following tables can operate as normal inputs or they can be assigned special functions in the PLC Setup.

Special functions for input bits IR 00000 through IR 00002 are set in DM 6642:

Bit address	PLC Setup setting (DM 6642 bits 08 to 15)		
	00	01	02, 03, or 04
IR 00000	Used as normal inputs.	Used as high-speed counter inputs.	Used as inputs for synchronized pulse control.
IR 00001			Used as a normal input.
IR 00002			Used as a normal input.

Special functions for input bits IR 00003 through IR 00006 are set in DM 6628:

Bit address	Bits in DM 6628	PLC Setup setting (in DM 6628)		
		0	1	2
IR 00003	00 to 03	Used as normal inputs.	Used as interrupt inputs (including counter mode).	Used as quick-response inputs.
IR 00004	04 to 07			
IR 00005	08 to 11			
IR 00006	12 to 15			

High-speed Counter Input Connection Examples

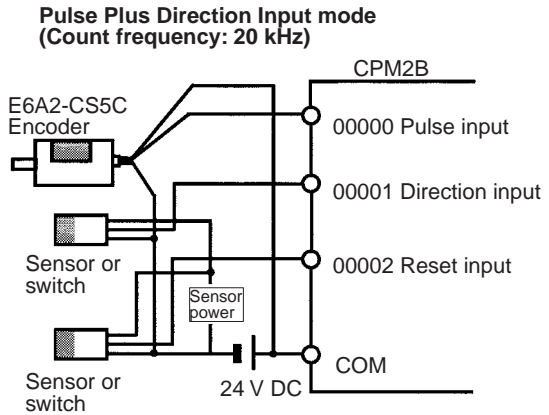
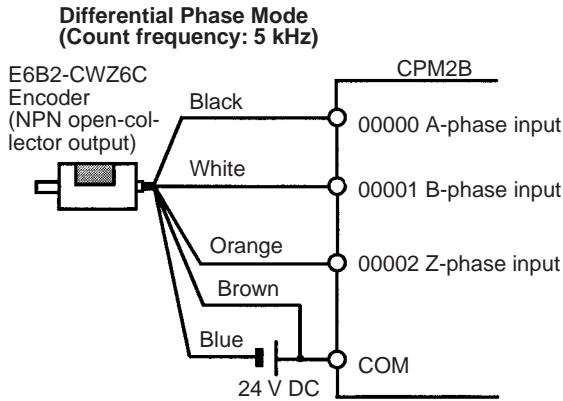

Leakage Current

A leakage current can cause false inputs when using 2-wire sensors (proximity switches or photoelectric switches) or limit switches with LEDs. False inputs won't occur if the leakage current is less than 1.0 mA (2.5 mA for IN00000 to IN00002). If the leakage current exceeds these values, insert a bleeder resistor in the circuit to reduce the input impedance, as shown in the following diagram.

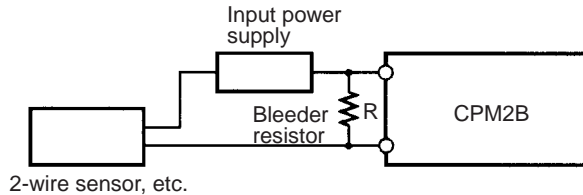

- I: Device's leakage current (mA)
- R: Bleeder resistance (kΩ)
- W: Bleeder resistor's power rating (W)
- L_C: CPM2B's input impedance (kΩ)
- I_C: CPM2B's input current (mA)
- E_C: CPM2B's OFF voltage (V) = 5.0 V

$$R = \frac{L_C \times 5.0}{I \times L_C - 5.0} \text{ k}\Omega \text{ max.} \quad W = \frac{2.3}{R} \text{ W min.}$$

The equations above were derived from the following equations:

$$I \times \frac{R \times \frac{\text{Input voltage (24)}}{\text{Input Current (I}_C)}}{R + \frac{\text{Input voltage (24)}}{\text{Input Current (I}_C)}} \leq \text{OFF voltage (E}_C: 5.0)$$

$$W \geq \frac{\text{Input voltage (24)}}{R} \times \text{Input voltage (24)} \times \text{tolerance (4)}$$

Refer to 2-1-3 I/O Specifications for details on the values L_C, I_C, and E_C. The input impedance, input current, and OFF voltage may vary depending on the input being used. (IN00000 through IN00002 have different values.)

Inductive Loads

When connecting an inductive load to an input, connect a diode in parallel with the load. The diode should satisfy the following requirements:

- 1,2,3...**
1. Peak reverse-breakdown voltage must be at least 3 times the load voltage.
 2. Average rectified current must be 1 A.

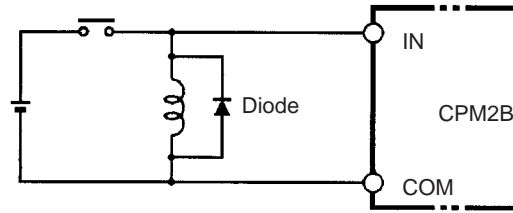

3-5-4 Output Wiring

Relay Output Wiring

Wire the outputs to the CPM2B's CPU Board and Expansion I/O Boards as shown in the following diagrams.

Don't exceed the output capacity or the maximum common current. Refer to 2-1-3 I/O Specifications for details.

⚠ WARNING The PLC outputs may remain ON or OFF due to fusing or burning of the output relays or destruction of the output transistors. External safety measures must be provided to ensure safety in the system. Not providing proper safety measures may result in serious accidents.

CPU Boards with 32 I/O Points and Relay Outputs (CPM2B-32C□DR-D)

Terminal Block #1 (Left side)

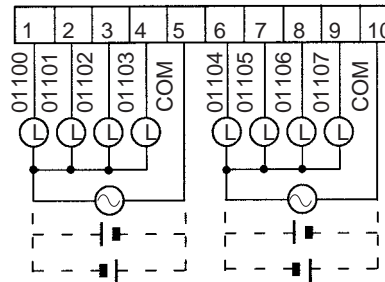
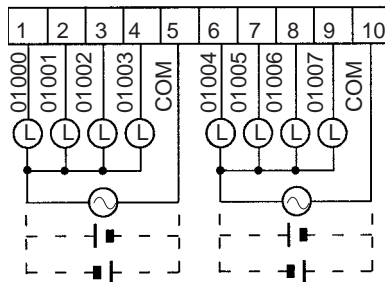

Terminal Block #2 (Right side)

Output capacity	Max. common capacity
2 A (250 V AC or 24 V DC)	4 A/common

CPU Boards with 40 I/O Points and Relay Outputs (CPM2B-40C2DR-D)

Terminal Block #1 (Left side)

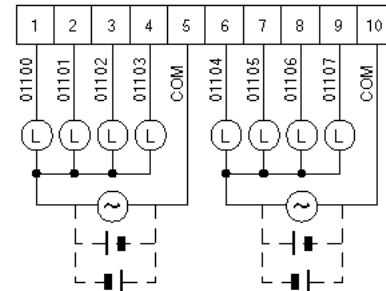
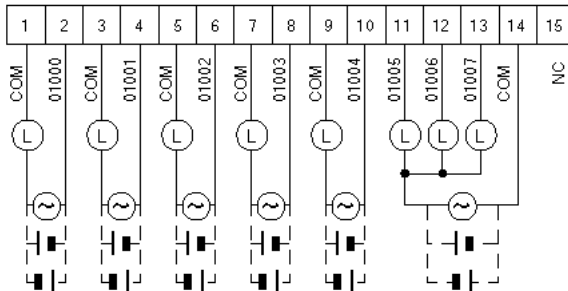

Terminal Block #2 (Right side)

Output capacity	Max. common capacity
2 A (250 V AC or 24 V DC)	4 A/common

Expansion I/O Boards with 32 I/O Points and Relay Outputs (CPM2B-32EDR)

Terminal Block #1
(Left side)

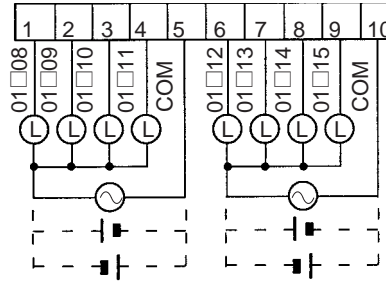
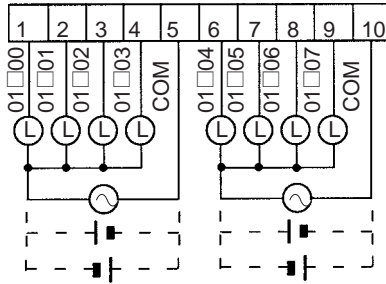

Terminal Block #2
(Right side)

Output capacity	Max. common capacity
2 A (250 V AC or 24 V DC)	4 A/common

Expansion I/O Boards with 40 I/O Points and Relay Outputs (CPM2B-40EDR)

Terminal Block #1
(Left side)

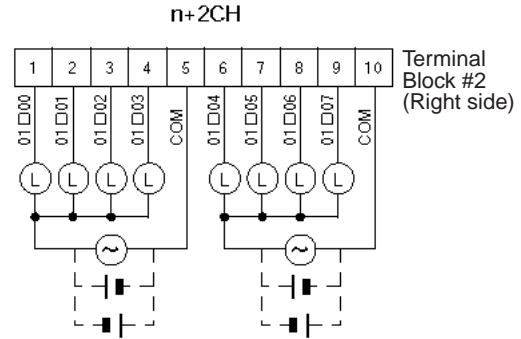
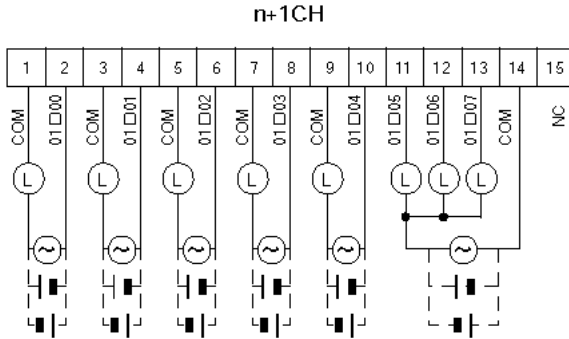

Terminal Block #2
(Right side)

Output capacity	Max. common capacity
2 A (250 V AC or 24 V DC)	4 A/common

CPU Boards with Sinking Transistor Outputs (CPM2B-32C□DT-D, CPM2B-32C□DT1-D12)

Output connector

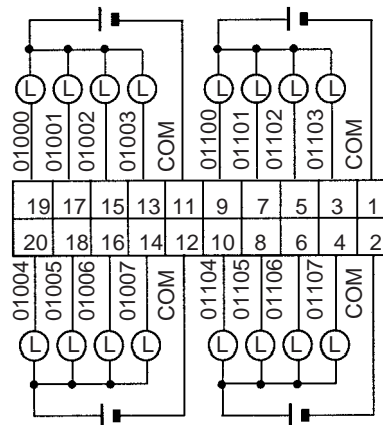

Output capacity	Max. common capacity
01000, 01001: 200 mA (30 V DC)	1.2 A/common
01002 and up: 300 mA (30 V DC)	

Expansion I/O Boards with 32 I/O Points and Sinking Transistor Outputs (CPM2B-32EDT, CPM2B-32ED1T)

Output connector

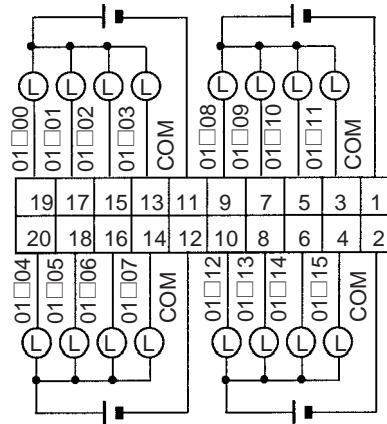

Output capacity	Max. common capacity
300 mA (30 V DC)	1.2 A/common

Expansion I/O Boards with 64 I/O Points and Sinking Transistor Outputs (CPM2B-64EDT)

IR n+1

IR n+2

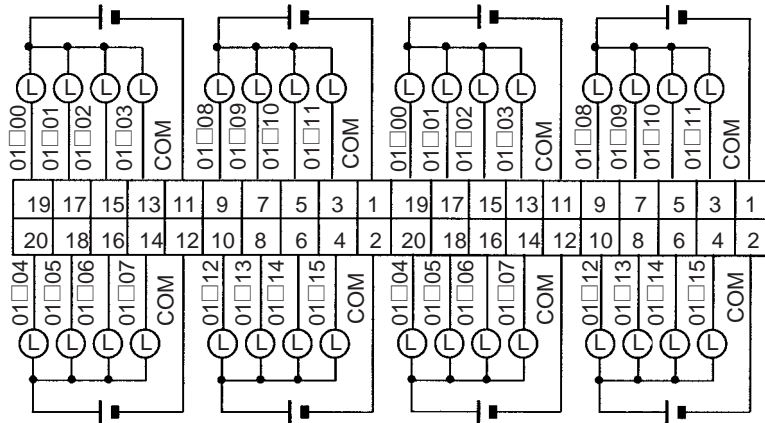

Output capacity	Max. common capacity
300 mA (30 V DC)	2.4 A/common

Using Pulse Outputs

Use the PULS(65), SPED(—), ACC(—), PWM(—), and SYNC(—) instructions to produce pulse outputs (rather than normal outputs) from output bits IR 01000 and IR 01001. Pulse outputs are possible from CPU Boards with transistor outputs only.

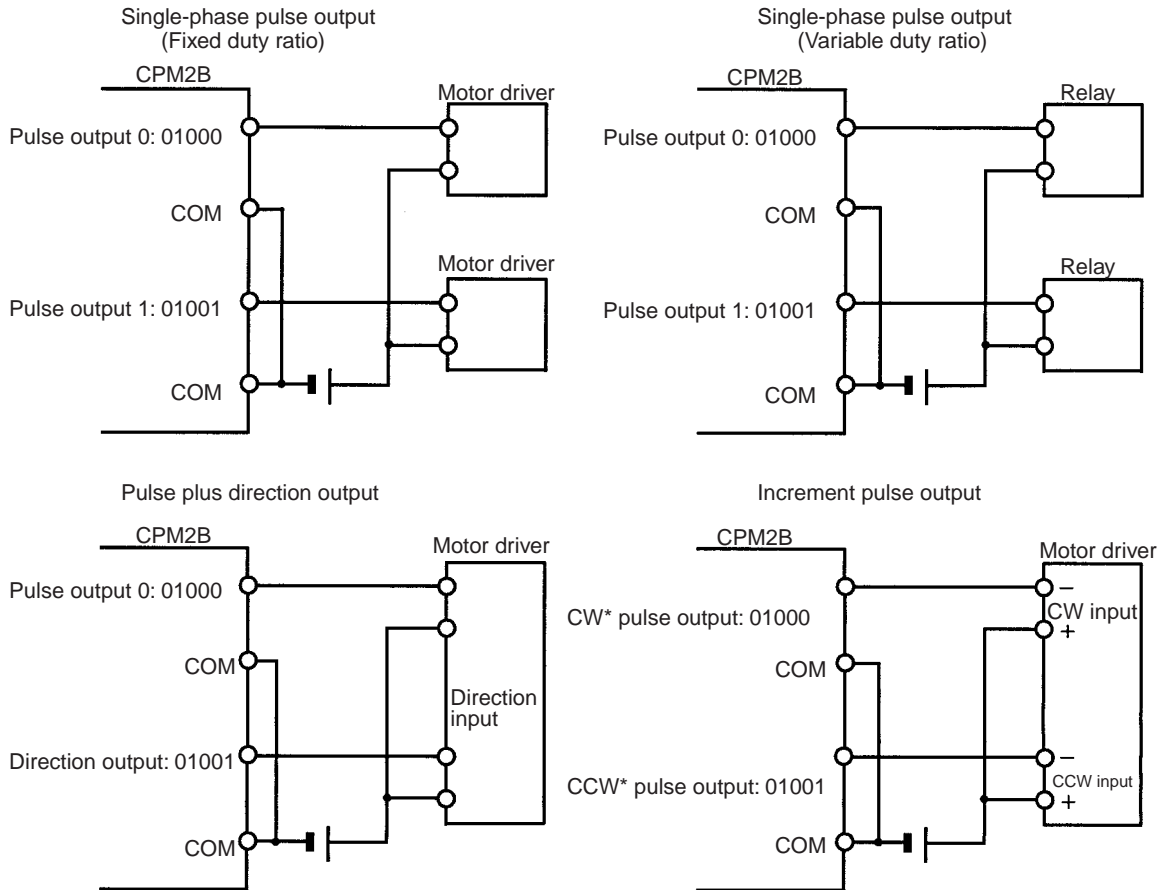

Note *CW is clockwise and CCW is counter-clockwise.

Output Wiring Precautions

Observe the following precautions to protect the PLC's internal components.

Output Short Protection

The output or internal circuitry might be damaged when the load connected to an output is short-circuited, so it is recommended to install a protective fuse in each output circuit.

Inductive Loads

When connecting an inductive load to an input, connect a surge protector or diode in parallel with the load.

The surge protector's components should have the following ratings:

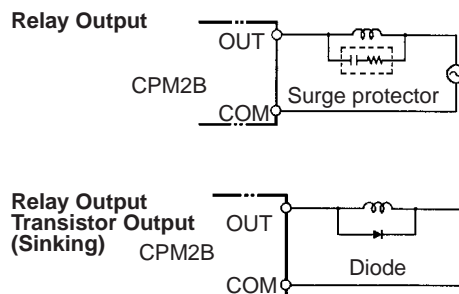

The diode should satisfy the following requirements:

- Peak reverse-breakdown voltage must be at least 3 times the load voltage.
- Average rectified current must be 1 A.

Inrush Current Considerations

When a relay or transistor output is used to switch a load with a high inrush current such as an incandescent lamp, suppress the inrush current as shown below.

Countermeasure 1

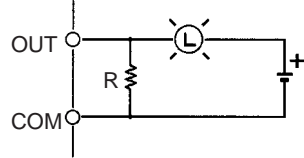

Providing a dark current of approx. one-third of the rated value through an incandescent lamp

Countermeasure 2

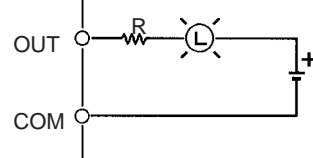

Providing a limiting resistor

Fuse Insertion

The CPM2B with transistor output may burn if the load is short-circuited, therefore, insert a protective fuse in series with the load.

SECTION 4

Memory Areas

This section describes the structure of the PLC memory areas and explains how to use them.

4-1	Introduction	70
4-1-1	Functions	71
4-2	I/O Allocation	72
4-3	SR Area	76
4-4	AR Area	79
4-5	PLC Setup	82
4-5-1	Changing the PLC Setup	82
4-5-2	PLC Setup Settings	83
4-6	Error Log	88

4-1 Introduction

Most data areas in the CPM2B can be accessed as bits or words. (The TR Area can be accessed by bit address only and the DM Area can be accessed by word address only.)

The following diagram shows the structure of the IR Area and the relationship between bit and word addresses.

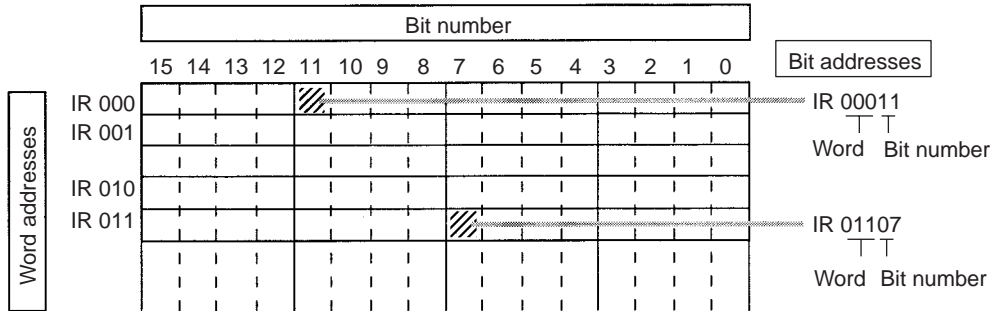

Data area		Size	Words	Bits	Function
IR Area	Input bits	160 bits (10 words)	IR 000 to IR 009	IR 00000 to IR 00915 (See note 1.)	These bits can be allocated to the external I/O terminals.
	Output bits	160 bits (10 words)	IR 010 to IR 019	IR 01000 to IR 01915	
	Work bits	928 bits (58 words)	IR 020 to IR 049 IR 200 to IR 227	IR 02000 to IR 04915 IR 20000 to IR 22715	Work bits can be freely used within the program.
SR Area		448 bits (28 words)	SR 228 to SR 255	SR 22800 to SR 25515	These bits serve specific functions such as flags and control bits.
TR Area		8 bits	---	TR 0 to TR 7	These bits are used to temporarily store ON/OFF status at program branches.
HR Area		320 bits (20 words)	HR 00 to HR 19	HR 0000 to HR 1915	These bits store data and retain their ON/OFF status when power is turned OFF.
AR Area		384 bits (24 words)	AR00 to AR 23	AR 0000 to AR 2315	These bits serve specific functions such as flags and control bits.
LR Area		256 bits (16 words)	LR 00 to LR 15	LR 0000 to LR 1515	Used for a 1:1 data link with another PLC.
Timer/Counter Area		256 bits	TIM/CNT 000 to TIM/CNT 255		The same numbers are used for both timers and counters.
DM Area	Read/write	2,026 words	DM 0000 to DM 1999 DM 2022 to DM 2047		DM Area data can be accessed in word units only. Word values are retained when the power is turned OFF.
	Error log	22 words	DM 2000 to DM 2021		
	Read-only	456 words	DM 6144 to DM 6599		The read-only area and PLC Setup cannot be overwritten from program. Change these settings with a Programming Device.
	PLC Setup	56 words	DM 6600 to DM 6655		

- Note**
1. Input bits IR 00108 to IR 00111 for 32-point CPU Boards reflect the status of the DIP switch on the CPU Board.
 2. The contents of the HR Area, AR Area, Counter Area, and read/write DM Area are backed up by the CPU Board's backup battery or capacitor. If the battery or capacitor discharges completely, memory contents will be returned to their default settings.
 3. The program and data in DM 6144 to DM 6655 are stored in flash memory.

4-1-1 Functions

IR Area	<p>The functions of the IR Area are explained below.</p> <p>IR Area bits in the input and output words are allocated to terminals on the CPU Board and Expansion I/O Boards. They reflect the ON/OFF status of input and output signals. Input bits begin at IR 00000, and output bits begin at IR 01000.</p> <p>IR words that are not allocated to inputs or outputs can be used as work words.</p>
Work Bits	<p>The work bits can be used freely within the program. They can only be used within the program, however, and not for direct external I/O.</p>
SR Area	<p>These bits mainly serve as flags for CPM2B operation or contain present and set values for various functions. SR 253 to SR 255 are read-only. Refer to <i>4-3 SR Area</i> for details on the various bit functions.</p>
TR Area	<p>When a complex ladder diagram cannot be programmed in mnemonic code just as it is, these bits are used to temporarily store ON/OFF execution conditions at program branches. They are used only for mnemonic code. When programming directly with ladder diagrams using the Support Software, TR bits are automatically processed for you.</p> <p>The same TR bits cannot be used more than once within the same instruction block, but can be used again in different instruction blocks. The ON/OFF status of TR bits cannot be monitored from a Programming Device.</p>
HR Area	<p>These bits retain their ON/OFF status even after the PLC power supply has been turned OFF or when operation begins or stops. They are used in the same way as work bits.</p>
AR Area	<p>These bits mainly serve as flags related to PLC operation. These bits retain their status even after the PLC power supply has been turned OFF or when operation begins or stops. Refer to <i>4-4 AR Area</i> for details on the various bit functions.</p>
LR Area	<p>When the CPM2B is linked 1:1 with another CPM2B or a CPM1/CPM1A/CPM2A/CPM2C/SRM1(-V2), a CQM1, a C200HS or a C200HX/HG/HE PLC, these bits are used to share data.</p> <p>LR words can be used as work words when they are not used for a 1:1 PLC Link.</p>
Timer/Counter Area	<p>This area is used to manage timers and counters created with TIM, TIMH(15), TMHH(—), TIML(—), CNT, and CNTR(12). The same numbers are used for both timers and counters and each number can be used only once in the user program. Do not use the same TC number twice even for different instructions.</p> <p>Use TC numbers 000 to 003 for TIMH(15) and TC numbers 004 to 007 for TMHH(—). When these timer numbers are used, timing is performed as an interrupt process and the cycle time is not affected.</p> <p>TC numbers are used to create timers and counters, as well as to access Completion Flags and present values (PVs). If a TC number is designated for word data, it will access the present value (PV); if it is used for bit data, it will access the Completion Flag for the timer/counter.</p>
DM Area	<p>DM Area data is accessed in word units only. The contents of the DM Area are retained even after the PLC power supply has been turned OFF or when operation begins or stops.</p> <p>DM words DM 0000 to DM 1999 and DM 2022 to DM 2047 can be used freely in the program; other DM words are allocated specific functions.</p> <p>DM 2000 to DM 2021 contain the error log information. Refer to <i>Section 4-6 Error Log</i> for details on the error log.</p> <p>DM 6600 to DM 6655 contain the PLC Setup. Refer to <i>4-5 PLC Setup</i> for details.</p>

4-2 I/O Allocation

IR bits are allocated to actual input terminals and output terminals on the CPU Board and Expansion I/O Boards. IR words that are not allocated to inputs or outputs can be used as work words.

CPU Board I/O Allocation

CPU Board inputs are allocated input bits in IR words IR 000 to IR 001 and CPU Board outputs are allocated output bits in IR words IR 010 to IR 011. The bit allocations are shown in detail in the following diagrams.

32-point CPU Boards

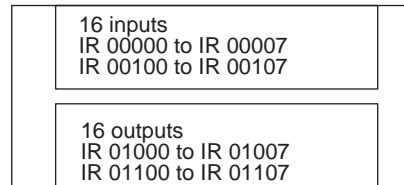

Bits		15	14	13	12	11	10	09	08	07	06	05	04	03	02	01	00	
Inputs	IR 000	Do not use																
	IR 001																	
Outputs	IR 010																	
	IR 011																	

- Note**
1. The unused bits in IR 000 and IR 001 cannot be used as work bits.
 2. IR 00108 to IR 00111 are used as an input DIP switch.

40-point CPU Boards

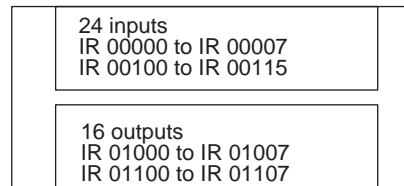

Bits		15	14	13	12	11	10	09	08	07	06	05	04	03	02	01	00
Inputs	IR 000	Do not use															
	IR 001																
Outputs	IR 010																
	IR 011																

Expansion I/O Board I/O Allocation

- Up to three Expansion I/O Boards can be connected to a CPU Board.
- Expansion Boards with 32 I/O points are allocated one input word and one output word, and models with 40 or 64 I/O points are allocated two input words and two output words.
- Input and output words are allocated in the order that the Boards are connected to the CPU Board, starting from the top terminal block.

m: The last input word allocated to the CPU Board or to the previous Expansion Board if one is already connected.

n: The last output word allocated to the CPU Board or to the previous Expansion Board if one is already connected.

32-point Expansion I/O Boards

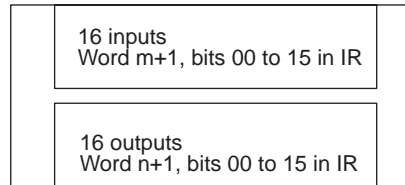

Bits		15	14	13	12	11	10	09	08	07	06	05	04	03	02	01	00
Inputs	m+1																
Outputs	n+1																

40-point Expansion I/O Boards

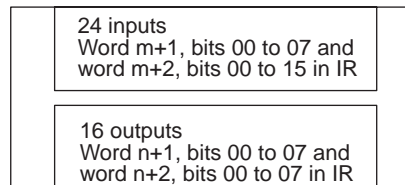

Bits		15	14	13	12	11	10	09	08	07	06	05	04	03	02	01	00
Inputs	m+1	Do not use															
	m+2																
Outputs	n+1																
	n+2																

64-point Expansion I/O Boards

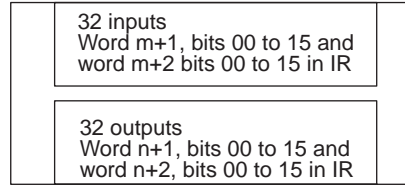

Bits		15	14	13	12	11	10	09	08	07	06	05	04	03	02	01	00
Inputs	m+1																
	m+2																
Outputs	n+1																
	n+2																

Analog I/O Board Allocation

The maximum number of Analog I/O Boards that can be connected depends on the model being used, as shown in the following table.

Model	Number of inputs	Number of outputs	Maximum number of Boards
CPM2B-MAD63	6 inputs	3 outputs	1
CPM2B-MAD42	4 inputs	2 outputs	2
CPM2B-MAD21	2 inputs	1 outputs	3

(When two CPM2B-MAD42 Analog I/O Boards are connected, there will be 8 inputs and 4 outputs.)

CPM2B-MAD63

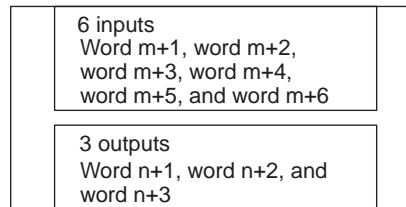

CPM2B-MAD42

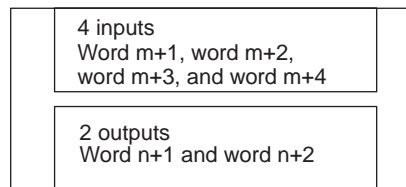

CPM2B-MAD21

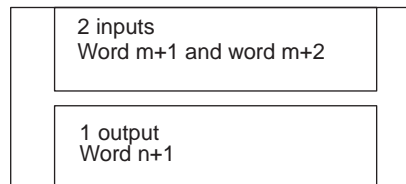

I/O Word Allocations

CPU Board and Three Expansion I/O Boards

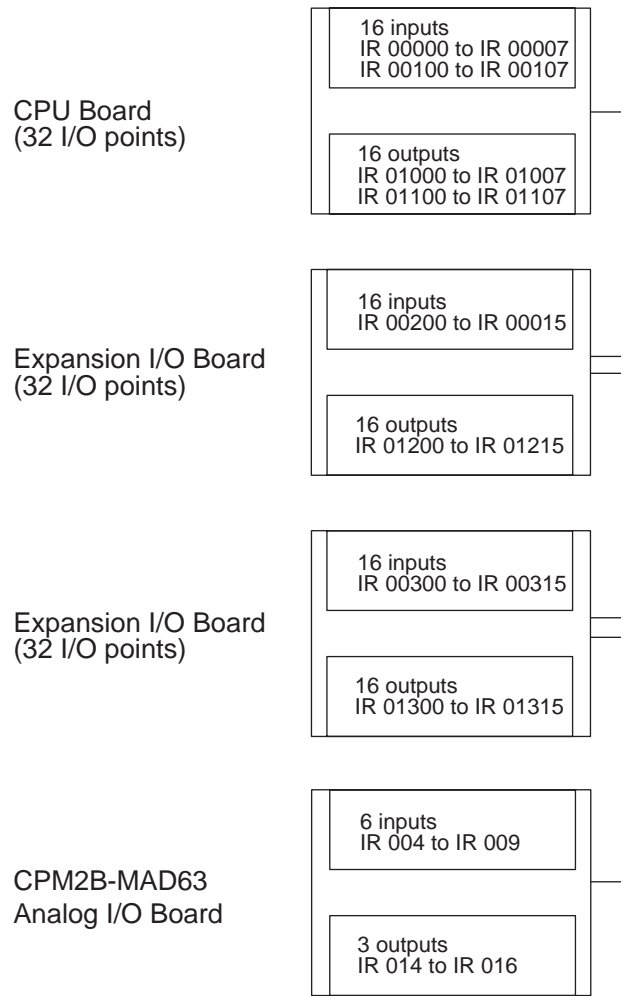

	15	14	13	12	11	10	9	8	7	6	5	4	3	2	1	0			
Input	IR 000																		
	IR 001																		
	IR 002																		
	IR 003																		
	IR 004	Input data 1 (4-digit hexadecimal)																	
	IR 005	Input data 2 (4-digit hexadecimal)																	
	IR 006	Input data 3 (4-digit hexadecimal)																	
	IR 007	Input data 4 (4-digit hexadecimal)																	
	IR 008	Input data 5 (4-digit hexadecimal)																	
	IR 009	Input data 6 (4-digit hexadecimal)																	
Output	IR 010																		
	IR 011																		
	IR 012																		
	IR 013																		
	IR 014	Output 1 range code						Input 2 range code				Input 1 range code							
	IR 015	Output data 1 (4-digit hexadecimal)						Output 2 range code				Input 4 range code				Input 3 range code			
	IR 016	Output data 2 (4-digit hexadecimal)						Output 3 range code				Input 6 range code				Input 5 range code			
	Output data 3 (4-digit hexadecimal)																		

Note Input bits IR 00108 to IR 00111 reflect the status of the DIP switch on the CPU Board.

4-3 SR Area

These bits mainly serve as flags related to CPM2A/CPM2C operation or contain present and set values for various functions. The functions of the SR Area are explained in the following table.

Note “Read-only” words and bits can be read as status in controller PLC operation, but they cannot be written from the ladder program. Bits and words that are “Not used” are also read-only.

Word(s)	Bit(s)	Function	Read/write
SR 228, SR 229	00 to 15	Pulse Output PV 0 Contains the pulse output PV (–16,777,215 to 16,777,215). SR 22915 acts as the sign bit; a negative number is indicated when SR 22915 is ON. (The same PV data can be read immediately with PRV(62).) Only Pulse Output PV 0 is used for ACC(—).	Read-only
SR 230, SR 231	00 to 15	Pulse Output PV 1 Contains the pulse output PV (–16,777,215 to 16,777,215). SR 23115 acts as the sign bit; a negative number is indicated when SR 23115 is ON. (The same PV data can be read immediately with PRV(62).)	
SR 232 to SR 235	00 to 15	Macro Function Input Area Contains the input operands for MCRO(99). (Can be used as work bits when MCRO(99) is not used.)	Read/write
SR 236 to SR 239	00 to 15	Macro Function Output Area Contains the output operands for MCRO(99). (Can be used as work bits when MCRO(99) is not used.)	
SR 240	00 to 15	Interrupt Input 00003 Counter Mode SV SV when interrupt input 00003 is used in counter mode (4 digits hexadecimal). (Can be used as work bits when interrupt input 00003 is not used in counter mode.)	
SR 241	00 to 15	Interrupt Input 00004 Counter Mode SV SV when interrupt input 00004 is used in counter mode (4 digits hexadecimal). (Can be used as work bits when interrupt input 00004 is not used in counter mode.)	
SR 242	00 to 15	Interrupt Input 00005 Counter Mode SV SV when interrupt input 00005 is used in counter mode (4 digits hexadecimal). (Can be used as work bits when interrupt input 00005 is not used in counter mode.)	
SR 243	00 to 15	Interrupt Input 00006 Counter Mode SV SV when interrupt input 00006 is used in counter mode (4 digits hexadecimal). (Can be used as work bits when interrupt input 00006 is not used in counter mode.)	
SR 244	00 to 15	Interrupt Input 00003 Counter Mode PV Counter PV when interrupt input 00003 is used in counter mode (4 digits hexadecimal).	
SR 245	00 to 15	Interrupt Input 00004 Counter Mode PV Counter PV when interrupt input 00004 is used in counter mode (4 digits hexadecimal).	
SR 246	00 to 15	Interrupt Input 00005 Counter Mode PV Counter PV when interrupt input 00005 is used in counter mode (4 digits hexadecimal).	
SR 247	00 to 15	Interrupt Input 00006 Counter Mode PV Counter PV when interrupt input 00006 is used in counter mode (4 digits hexadecimal).	

Word(s)	Bit(s)	Function	Read/write
SR 248, SR 249	00 to 15	High-speed Counter PV Area The PVs can have the following values. The leftmost digit of SR 249 acts as the sign indicator; a negative number is indicated when the leftmost digit of SR 249 is F. Differential phase input mode: –8,388,608 (F838 8608) to 8,388,607 Pulse +direction input mode: –8,388,608 (F838 8608) to 8,388,607 Up/down pulse input mode: –8,388,608 (F838 8608) to 8,388,607 Increment mode: 0 to 16,777,215 Synchronized pulse control: 0 to 20,000 Hz (Can be used as work bits when the high-speed counter is not used.)	Read-only
SR 250	00 to 15	Analog Setting 0 Used to store the 4-digit BCD set value (0000 to 0200) from analog control 0.	
SR 251	00 to 15	Analog Setting 1 Used to store the 4-digit BCD set value (0000 to 0200) from analog control 1.	
SR 252	00	High-speed Counter Reset Bit	Read/write
	01 to 03	Not used.	
	04	Pulse Output 0 PV Reset Bit Turn ON to clear the PV of pulse output 0.	Read/write
	05	Pulse Output 1 PV Reset Bit Turn ON to clear the PV of pulse output 1.	
	06, 07	Not used.	
	08	Peripheral Port Reset Bit Turn ON to reset the peripheral port. Automatically turns OFF when reset is complete.	Read/write
	09	RS-232C Port Reset Bit Turn ON to reset the RS-232C port. Automatically turns OFF when reset is complete.	
	10	PLC Setup Reset Bit Turn ON to initialize PLC Setup (DM 6600 through DM 6655). Automatically turns OFF again when reset is complete. Only effective if the PLC is in PROGRAM mode.	
	11	Forced Status Hold Bit (See note.) OFF: The forced status of bits that are forced set/reset is cleared when switching between PROGRAM mode and MONITOR mode. ON: The status of bits that are forced set/reset are maintained when switching between PROGRAM mode and MONITOR mode. The PLC Setup can be set to maintain the status of this bit when the PLC is turned OFF.	
	12	I/O Hold Bit (See note.) OFF: IR and LR bits are reset when starting or stopping operation. ON: IR and LR bit status is maintained when starting or stopping operation. The PLC Setup can be set to maintain the status of this bit when the PLC is turned OFF.	
	13	Not used.	
	14	Error Log Reset Bit Turn ON to clear error log. Automatically turns OFF again when operation is complete.	Read/write
	15	Not used.	

Word(s)	Bit(s)	Function	Read/write
SR 253	00 to 07	FAL Error Code The error code (a 2-digit number) is stored here when an error occurs. The FAL number is stored here when FAL(06) or FALS(07) is executed. This word is reset (to 00) by executing a FAL 00 instruction or by clearing the error from a Programming Device.	Read-only
	08	Battery Error Flag Turns ON when the CPU Board backup battery's voltage is too low.	
	09	Cycle Time Overrun Flag Turns ON when a cycle time overrun occurs (i.e., when the cycle time exceeds the maximum cycle time set in the PLC Setup).	
	10,11	Not used.	
	12	Changing RS-232C Setup Flag Turns ON when the RS-232C port's settings are being changed.	Read/write
	13	Always ON Flag	Read-only
	14	Always OFF Flag	
	15	First Cycle Flag Turns ON for 1 cycle at the start of operation.	
SR 254	00	1-minute clock pulse (30 seconds ON; 30 seconds OFF)	Read-only
	01	0.02-second clock pulse (0.01 second ON; 0.01 second OFF)	
	02	Negative (N) Flag Turns ON when the result of a calculation is negative (leftmost bit of binary result ON.)	
	03	Not used.	Read-only
	04	Overflow (OF) Flag Turns ON when an overflow occurs in a signed binary calculation.	
	05	Underflow (UF) Flag Turns ON when an underflow occurs in a signed binary calculation.	
	06	Differential Monitor Complete Flag Turns ON when differential monitoring is completed.	
	07	STEP(08) Execution Flag Turns ON for 1 cycle only at the start of process based on STEP(08).	
08 to 15	Not used.		
SR 255	00	0.1-second clock pulse (0.05 second ON; 0.05 second OFF)	Read-only
	01	0.2-second clock pulse (0.1 second ON; 0.1 second OFF)	
	02	1.0-second clock pulse (0.5 second ON; 0.5 second OFF)	
	03	Instruction Execution Error (ER) Flag Turns ON when an error occurs during execution of an instruction.	
	04	Carry (CY) Flag Turns ON when there is a carry in the results of an instruction execution.	
	05	Greater Than (GR) Flag Turns ON when the result of a comparison operation is "greater."	
	06	Equals (EQ) Flag Turns ON when the result of a comparison operation is "equal," or when the result of an instruction execution is 0.	
	07	Less Than (LE) Flag Turns ON when the result of a comparison operation is "less."	
08 to 15	Not used.		

Note DM 6601 in the PLC Setup can be set to maintain the previous status of the Forced Status Hold Bit (SR 25211) and the I/O Hold Bit (SR 25212) when power is turned OFF. Refer to 4-5 PLC Setup for details.

4-4 AR Area

These bits mainly serve as flags related to CPM2B operation. These bits retain their status even after the CPM2B power supply has been turned OFF or when operation begins or stops.

Word(s)	Bit(s)	Function
AR 00, AR 01	00 to 15	Not used.
AR 02	00 to 07	<p>Expansion Board Error Flags These flags turn ON when an error occurs in any of the connected Expansion I/O Boards or Analog I/O Boards. Flags starting from AR 0200 are allocated one at a time to the Boards in the order that the Boards are connected to the CPU Board.</p> <p>For Expansion I/O Boards, one flag is allocated to each Board. For Analog I/O Boards, the number of allocated flags depends on the model, as follows: CPM2B-MAD21: 1 flag CPM2B-MAD42: 2 flags CPM2B-MAD63: 3 flags</p>
	08 to 11	Number of Boards Connected
	12 to 15	Not used.
AR 03 to AR 07	00 to 15	Not used.
AR 08	00 to 03	<p>RS-232C Port Error Code (1-digit BCD) 0: Normal completion 1: Parity error 2: Frame error 3: Overrun error</p>
	04	<p>RS-232C Communications Error Flag Turns ON when an RS-232C port communications error occurs.</p>
	05	<p>RS-232C Transmit Ready Flag Turns ON when the PLC is ready to transmit data. (No-protocol and Host Link only)</p>
	06	<p>RS-232C Reception Completed Flag Turns ON when the PLC has completed reading data. (No-protocol only)</p>
	07	<p>RS-232C Reception Overflow Flag Turns ON when an overflow has occurred. (No-protocol only)</p>
	08 to 11	<p>Peripheral Port Error Code (1-digit BCD) 0: Normal completion 1: Parity error 2: Frame error 3: Overrun error</p>
	12	<p>Peripheral Port Communications Error Flag Turns ON when a peripheral port communications error occurs.</p>
	13	<p>Peripheral Port Transmit Ready Flag Turns ON when the PLC is ready to transmit data. (No-protocol and Host Link only)</p>
	14	<p>Peripheral Port Reception Completed Flag Turns ON when the PLC has completed reading data. (No-protocol only)</p>
	15	<p>Peripheral Port Reception Overflow Flag Turns ON when an overflow has occurred. (No-protocol only)</p>
AR 09	00 to 15	<p>RS-232C Port Reception Counter (4-digit BCD) Valid only when no-protocol communications are used.</p>
AR 10	00 to 15	<p>Peripheral Port Reception Counter (4-digit BCD) Valid only when no-protocol communications are used.</p>

Word(s)	Bit(s)	Function
AR 11 (Note 1)	00 to 07	High-speed Counter Range Comparison Flags 00 ON: Counter PV is within comparison range 1 01 ON: Counter PV is within comparison range 2 02 ON: Counter PV is within comparison range 3 03 ON: Counter PV is within comparison range 4 04 ON: Counter PV is within comparison range 5 05 ON: Counter PV is within comparison range 6 06 ON: Counter PV is within comparison range 7 07 ON: Counter PV is within comparison range 8
	08	High-speed Counter Comparison Operation ON: Operating OFF: Stopped
	09	High-speed Counter PV Overflow/Underflow Flag ON: An overflow or underflow occurred. OFF: Normal operation
	10	Not used.
	11	Pulse Output 0 Output Status ON: Pulse output 0 is accelerating or decelerating. OFF: Pulse output 0 is operating at a constant rate.
	12	Pulse Output 0 Overflow/Underflow Flag ON: An overflow or underflow occurred. OFF: Normal operation
	13	Pulse Output 0 Pulse Quantity Set Flag ON: Pulse quantity has been set. OFF: Pulse quantity has not been set.
	14	Pulse Output 0 Pulse Output Completed Flag ON: Completed OFF: Not completed
	15	Pulse Output 0 Output Status ON: Pulses being output. OFF: Stopped.
AR 12 (Note 1)	00 to 10	Not used.
	11	Pulse Output 1 Output Status ON: Pulse output 1 is accelerating or decelerating. OFF: Pulse output 1 is operating at a constant rate.
	12	Pulse Output 1 Overflow/Underflow Flag ON: An overflow or underflow occurred. OFF: Normal operation
	13	Pulse Output 1 Pulse Quantity Set Flag ON: Pulse quantity has been set. OFF: Pulse quantity has not been set.
	14	Pulse Output 1 Pulse Output Completed Flag ON: Completed OFF: Not completed
15	Pulse Output 1 Output Status ON: Pulses being output. OFF: Stopped.	

Word(s)	Bit(s)	Function
AR 13	00	Power-up PLC Setup Error Flag Turns ON when there is an error in DM 6600 to DM 6614 (the part of the PLC Setup area that is read at power-up).
	01	Start-up PLC Setup Error Flag Turns ON when there is an error in DM 6615 to DM 6644 (the part of the PLC Setup area that is read at the beginning of operation).
	02	RUN PLC Setup Error Flag Turns ON when there is an error in DM 6645 to DM 6655 (the part of the PLC Setup area that is always read).
	03, 04	Not used.
	05	Cycle Time Too Long Flag Turns ON if the actual cycle time is longer than the cycle time set in DM 6619.
	06, 07	Not used.
	08	Memory Area Specification Error Flag Turns ON when a non-existent data area address is specified in the program.
	09	Flash Memory Error Flag Turns ON when there is an error in flash memory.
	10	Read-only DM Error Flag Turns ON when a checksum error occurs in the read-only DM (DM 6144 to DM 6599).
	11	PLC Setup Error Flag Turns ON when a checksum error occurs in the PLC Setup area.
	12	Program Error Flag Turns ON when a checksum error occurs in the program memory (UM) area, or when an improper instruction is executed.
	13	Expansion Instruction Area Error Flag Turns ON when a checksum error occurs in the expansion instruction assignments area. The expansion instruction assignments will be cleared to their default settings.
	14	Data Save Error Flag Turns ON if data could not be retained with the backup battery or capacitor. The following words are normally backed up: DM read/write words (DM 0000 to DM 1999 and DM 2022 to DM 2047), Error Log (DM 2000 to DM 2021), HR Area, counter area, SR 25511, SR 25512 (if DM 6601 is set to hold I/O memory at startup), AR 23, operating mode (if DM 6600 is set to use the previous operating mode). If the above words cannot be retained, all data will be cleared except that AR 2114 will be turned ON in CPU Boards equipped with a clock. The CPU Board will start in PROGRAM mode if DM 6600 is set to use the previous operating mode. (If DM 6604 is set to generate an error, the PLC will start in PROGRAM mode regardless.)
	15	Not used.
AR 14	00 to 15	Maximum Cycle Time (4-digit BCD, see note 3) The longest cycle time since the beginning of operation is stored. It is not cleared when operation stops, but it is cleared when operation starts again.
AR 15	00 to 15	Current Cycle Time (4-digit BCD, see note 3) The most recent cycle time during operation is stored. The Current Cycle Time is not cleared when operation stops.
AR 16	00 to 15	Not used.
AR 17 (Note 2)	00 to 07	Minute (00 to 59, BCD)
	08 to 15	Hour (00 to 59, BCD)
AR 18 (Note 2)	00 to 07	Second (00 to 59, BCD)
	08 to 15	Minute (00 to 59, BCD)
AR 19 (Note 2)	00 to 07	Hour (00 to 23, BCD)
	08 to 15	Day of the Month (01 to 31, BCD)
AR 20 (Note 2)	00 to 07	Month (01 to 12, BCD)
	08 to 15	Year (00 to 99, BCD)

Word(s)	Bit(s)	Function
AR 21 (Note 2)	00 to 07	Day of the Week (00 to 06, BCD) 00: Sunday 01: Monday 02: Tuesday 03: Wednesday 04: Thursday 05: Friday 06: Saturday
	08 to 12	Not used.
	13	30-second Compensation Bit Turn this bit ON to round off to the nearest minute. When the seconds are 00 to 29, the seconds are cleared to 00 and the rest of the time setting is left unchanged. When the seconds are 30 to 59, the seconds are cleared to 00 and the time is incremented by one minute.
	14	Clock Stop Bit Turn this bit ON to stop the clock. The time/date can be overwritten while this bit is ON.
	15	Clock Set Bit To change the time/date, turn ON AR 2114, write the new time/date (being sure to leave AR 2114 ON), and then turn this bit ON to enable a new time/date setting. The clock will restart and both AR 2114 and AR 2115 will be turned OFF automatically.
AR 22	00 to 15	Not used.
AR 23	00 to 15	Power-off Counter (4-digit BCD) This is the count of the number of times that the power has been turned OFF. To clear the count, write "0000" from a Programming Device.

- Note**
1. The same data can be read immediately with PRV(62).
 2. The time and date can be set while AR 2114 is ON. The new setting becomes effective when AR 2115 is turned ON. (AR 2114 and AR 2115 are turned OFF automatically when the new setting goes into effect.)
 3. The units for the maximum and current cycle times are determined by the setting in bits 08 to 15 of DM 6618. A setting of 00 specifies 0.1-ms units, 01 specifies 0.1-ms units, 02 specifies 1-ms units, and 03 specifies 10-ms units.

4-5 PLC Setup

The PLC Setup comprises various operating parameters that control PLC operation. In order to make the maximum use of PLC functionality when using interrupt processing and communications functions, the PLC Setup may be customized according to operating conditions.

After the PLC Setup has been changed, be sure to switch the CPM2B to MONITOR or RUN mode or turn the power OFF and then ON again.

4-5-1 Changing the PLC Setup

The PLC Setup settings in DM 6600 to DM 6655 can be changed from a Programming Device. The CPM2B must be in PROGRAM mode in order to change the settings in DM 6600 to DM 6644. The settings in DM 6645 to DM 6655 can be changed in MONITOR or PROGRAM mode, but CPM2B's cycle time will be long if the settings are changed in MONITOR mode.

All of the PLC Setup settings are set to their defaults when the CPM2B is shipped. The default values for the PLC Setup are 0000 for all words (except for the low battery error enable in DM 6655 bits 12 to 15).

Effectiveness of Changes

PLC Setup settings are accessed at various times depending on the setting, as described below.

Words	Timing
DM 6600 to DM 6614	Accessed only when PLC's power supply is turned ON.
DM 6615 to DM 6644	Accessed only when program execution begins.
DM 6645 to DM 6655	Accessed regularly when the power is ON.

Since changes in the PLC Setup become effective only at the times given above, the PLC will have to be restarted to make changes in DM 6600 to DM 6614 effective, and program execution will have to be restarted to make changes in DM 6615 to DM 6644 effective.

Errors in the PLC Setup

If an incorrect PLC Setup setting is accessed, a non-fatal error (error code 9B) will be generated, the corresponding error flag (AR 1300 to AR 1302) will be turned ON, and the default setting will be used instead of the incorrect setting.

4-5-2 PLC Setup Settings

Word(s)	Bit(s)	Function
Startup Processing (DM 6600 to DM 6614)		
The following settings are effective after transfer to the PLC only after the PLC is restarted.		
DM 6600	00 to 07	Startup mode (effective when bits 08 to 15 are set to 02). 00: PROGRAM; 01: MONITOR; 02: RUN
	08 to 15	Startup mode designation 00: According to communications switch SW201 and peripheral port connection (See table at the bottom of this page.) 01: Continue operating mode last used before power was turned OFF. 02: Setting in 00 to 07
DM 6601	00 to 07	Not used.
	08 to 11	IOM Hold Bit (SR 25212) Status at Startup 0: Reset to 0; 1: Maintain previous status
	12 to 15	Forced Status Hold Bit (SR 25211) Status at Startup 0: Reset to 0; 1: Maintain previous status
DM 6602	00 to 03	Program memory write-protection 0: Program memory unprotected 1: Program memory write-protected (except DM 6602 itself)
	04 to 07	Programming Console display language 0: English; 1: Japanese
	08 to 11	Expansion instruction function code assignments 0: Default settings 1: User assignments
	12 to 15	Not used.
DM 6603	00 to 15	Not used.
DM 6604	00 to 07	00: A memory error will not be generated if data could not be retained by the battery. 01: A memory error will be generated if data could not be retained by the battery.
	08 to 15	Not used.
DM 6605 to DM 6614	00 to 15	Not used.

Note The startup operating mode will be as shown in the following table is bits 08 to 15 of DM 6600 are set to 00.

Peripheral port connected to	Communications switch SW201	
	OFF	ON
Nothing	PROGRAM	RUN
Programming Console	Mode set on Programming Console mode switch	PROGRAM (The CPM2B will not be able to communicate with Programming Console.)
Other Programming Device	PROGRAM (The CPM2B will not be able to communicate with Programming Device.)	PROGRAM

Word(s)	Bit(s)	Function
Cycle Time Settings (DM 6615 to DM 6619)		
The following settings are effective after transfer to the PLC the next time operation is started.		
DM 6615	00 to 15	Not used.
DM 6616	00 to 07	Servicing time for RS-232C port (Effective when bits 08 to 15 are set to 01.) 00 to 99 (BCD): Percentage of cycle time used to service RS-232C port.
	08 to 15	RS-232C port servicing setting enable 00: 5% of the cycle time 01: Use time in bits 00 to 07.
DM 6617	00 to 07	Servicing time for peripheral port (Effective when bits 08 to 15 are set to 01.) 00 to 99 (BCD): Percentage of cycle time used to service peripheral.
	08 to 15	Peripheral port servicing setting enable 00: 5% of the cycle time 01: Use time in bits 00 to 07.
DM 6618	00 to 07	Cycle monitor time (Effective when bits 08 to 15 are set to 01, 02, or 03.) 00 to 99 (BCD): Setting (See bits 08 to 15, below.) A fatal error will be generated and PLC operation will stop if the cycle time exceeds the cycle monitor time set here.
	08 to 15	Cycle monitor enable (Setting in 00 to 07 × units; 99 s max.) 00: 120 ms (setting in bits 00 to 07 disabled) 01: Setting units: 10 ms 02: Setting units: 100 ms 03: Setting units: 1 s
DM 6619	00 to 15	Minimum cycle time 0000: Variable (no minimum) 0001 to 9999 (BCD): Minimum time in ms
Interrupt Processing (DM 6620 to DM 6639)		
The following settings are effective after transfer to the PLC the next time operation is started.		
DM 6620	00 to 03	Input time constant for IR 00000 to IR 00002 0: 10 ms; 1: 1 ms; 2: 2 ms; 3: 3 ms; 4: 5 ms; 5: 10 ms; 6: 20 ms; 7: 40 ms; 8: 80 ms
	04 to 07	Input time constant for IR 00003 and IR 00004 (Setting same as bits 00 to 03)
	08 to 11	Input time constant for IR 00005 and IR 00006 (Setting same as bits 00 to 03)
	12 to 15	Input time constant for IR 00007 to IR 00011 (Setting same as bits 00 to 03)
DM 6621	00 to 07	Input time constant for IR 001 00: 10 ms 01: 1 ms 02: 2 ms 03: 3 ms 04: 5 ms 05: 10 ms 06: 20 ms 07: 40 ms 08: 80 ms
	08 to 15	Input constant for IR 002 (Setting same as for IR 001.)
DM 6622	00 to 07	Input constant for IR 003 (Setting same as for IR 001.)
	08 to 15	Input constant for IR 004 (Setting same as for IR 001.)
DM 6623	00 to 07	Input constant for IR 005 (Setting same as for IR 001.)
	08 to 15	Input constant for IR 006 (Setting same as for IR 001.)
DM 6624	00 to 07	Input constant for IR 007 (Setting same as for IR 001.)
	08 to 15	Input constant for IR 008 (Setting same as for IR 001.)
DM 6625	00 to 07	Input constant for IR 009 (Setting same as for IR 001.)
	08 to 15	Not used.
DM 6626 to DM 6627	00 to 15	Not used.

Word(s)	Bit(s)	Function
DM6628	00 to 03	Interrupt enable for IR 00003 (0: Normal input; 1: Interrupt input; 2: Quick-response)
	04 to 07	Interrupt enable for IR 00004 (0: Normal input; 1: Interrupt input; 2: Quick-response)
	08 to 11	Interrupt enable for IR 00005 (0: Normal input; 1: Interrupt input; 2: Quick-response)
	12 to 15	Interrupt enable for IR 00006 (0: Normal input; 1: Interrupt input; 2: Quick-response)
DM 6629	00 to 03	PV coordinate system for pulse output 0 0: Relative coordinates; 1: Absolute coordinates
	04 to 07	PV coordinate system for pulse output 1 0: Relative coordinates; 1: Absolute coordinates
	08 to 15	Not used.
DM 6630 to DM 6641	00 to 15	Not used.
High-speed Counter Settings (DM 6642 to DM 6644)		
The following settings are effective after transfer to the PLC the next time operation is started.		
DM 6642	00 to 03	High-speed counter mode (Effective only when bits 08 to 15 are not set to 00.) 0: Differential phase mode (5 kHz) 1: Pulse + direction input mode (20 kHz) 2: Up/down input mode (20 kHz) 4: Increment mode (20 kHz)
	04 to 07	High-speed counter reset mode (Effective only when bits 08 to 15 are set to 01.) 0: Z phase and software reset; 1: Software reset only
	08 to 15	High-speed counter/Synchronized pulse control for IR 00000 to IR 00002 00: Don't use either function. 01: Use as high-speed counters. 02: Use for synchronized pulse control (10 to 500 Hz). 03: Use for synchronized pulse control (20 Hz to 1 kHz). 04: Use for synchronized pulse control (300 Hz to 20 kHz).
DM 6643, DM 6644	00 to 15	Not used.
RS-232C Port Communications Settings		
The following settings are effective after transfer to the PLC.		
If CPU Board communications switch SW202 is ON, communications through the RS-232C port are governed by the default settings (all 0) regardless of the settings in DM 6645 through DM 6649.		
DM 6645	00 to 03	Port settings 0: Standard (1 start bit, 7 data bits, even parity, 2 stop bits, 9,600 bps, Host Link unit number: 0) 1: Settings in DM 6646 (Any other setting will cause a non-fatal error and AR 1302 will turn ON.)
	04 to 07	CTS control setting 0: Disable CTS control; 1: Enable CTS control (Any other setting will cause a non-fatal error and AR 1302 will turn ON.)
	08 to 11	Link words for 1:1 PLC Link 0: LR 00 to LR 15 (Any other settings are ineffective.)
	12 to 15	Communications mode 0: Host Link; 1: No-protocol; 2: 1:1 PLC Link Slave; 3: 1:1 PLC Link Master; 4: NT Link (Any other setting causes a non-fatal error and turns ON AR 1302.)

Word(s)	Bit(s)	Function																																																																
DM 6646	00 to 07	Baud rate 00: 1,200 bps; 01: 2,400 bps; 02: 4,800 bps; 03: 9,600 bps; 04: 19,200 bps																																																																
	08 to 15	Frame format <table border="1" style="margin-left: 20px; width: 100%;"> <thead> <tr> <th></th> <th>Start bits</th> <th>Data bits</th> <th>Stop bits</th> <th>Parity</th> </tr> </thead> <tbody> <tr><td>00:</td><td>1 bit</td><td>7 bits</td><td>1 bit</td><td>Even</td></tr> <tr><td>01:</td><td>1 bit</td><td>7 bits</td><td>1 bit</td><td>Odd</td></tr> <tr><td>02:</td><td>1 bit</td><td>7 bits</td><td>1 bit</td><td>None</td></tr> <tr><td>03:</td><td>1 bit</td><td>7 bits</td><td>2 bits</td><td>Even</td></tr> <tr><td>04:</td><td>1 bit</td><td>7 bits</td><td>2 bits</td><td>Odd</td></tr> <tr><td>05:</td><td>1 bit</td><td>7 bits</td><td>2 bits</td><td>None</td></tr> <tr><td>06:</td><td>1 bit</td><td>8 bits</td><td>1 bit</td><td>Even</td></tr> <tr><td>07:</td><td>1 bit</td><td>8 bits</td><td>1 bit</td><td>Odd</td></tr> <tr><td>08:</td><td>1 bit</td><td>8 bits</td><td>1 bit</td><td>None</td></tr> <tr><td>09:</td><td>1 bit</td><td>8 bits</td><td>2 bits</td><td>Even</td></tr> <tr><td>10:</td><td>1 bit</td><td>8 bits</td><td>2 bits</td><td>Odd</td></tr> <tr><td>11:</td><td>1 bit</td><td>8 bits</td><td>2 bits</td><td>None</td></tr> </tbody> </table> (Any other setting specifies standard settings (1 start bit, 7 data bits; even parity, 2 stop bits), causes a non-fatal error, and turns ON AR 1302.)		Start bits	Data bits	Stop bits	Parity	00:	1 bit	7 bits	1 bit	Even	01:	1 bit	7 bits	1 bit	Odd	02:	1 bit	7 bits	1 bit	None	03:	1 bit	7 bits	2 bits	Even	04:	1 bit	7 bits	2 bits	Odd	05:	1 bit	7 bits	2 bits	None	06:	1 bit	8 bits	1 bit	Even	07:	1 bit	8 bits	1 bit	Odd	08:	1 bit	8 bits	1 bit	None	09:	1 bit	8 bits	2 bits	Even	10:	1 bit	8 bits	2 bits	Odd	11:	1 bit	8 bits	2 bits
	Start bits	Data bits	Stop bits	Parity																																																														
00:	1 bit	7 bits	1 bit	Even																																																														
01:	1 bit	7 bits	1 bit	Odd																																																														
02:	1 bit	7 bits	1 bit	None																																																														
03:	1 bit	7 bits	2 bits	Even																																																														
04:	1 bit	7 bits	2 bits	Odd																																																														
05:	1 bit	7 bits	2 bits	None																																																														
06:	1 bit	8 bits	1 bit	Even																																																														
07:	1 bit	8 bits	1 bit	Odd																																																														
08:	1 bit	8 bits	1 bit	None																																																														
09:	1 bit	8 bits	2 bits	Even																																																														
10:	1 bit	8 bits	2 bits	Odd																																																														
11:	1 bit	8 bits	2 bits	None																																																														
DM 6647	00 to 15	Transmission delay (0000 to 9999 BCD sets a delay of 0 to 99,990 ms.) (Any other setting specifies a delay of 0 ms, causes a non-fatal error, and turns ON AR 1302.)																																																																
DM 6648	00 to 07	Node number (Host Link) 00 to 31 (BCD) (Any other setting specifies a node number of 00, causes a non-fatal error, and turns ON AR 1302.)																																																																
	08 to 11	Start code selection for no-protocol communications 0: Disables start code; 1: Enables start code in DM 6649 (Any other setting disables the start code, causes a non-fatal error, and turns ON AR 1302.)																																																																
	12 to 15	End code selection for no-protocol communications 0: Disables end code; 1: Enables end code in DM 6649; 2: Sets end code of CR, LF. (Any other setting disables the end code, causes a non-fatal error, and turns ON AR 1302.)																																																																
DM 6649	00 to 07	Start code (00 to FF) (This setting is valid only when bits 8 to 11 of DM 6648 are set to 1.)																																																																
	08 to 15	When bits 12 to 15 of DM 6648 set to 0: Sets the number of bytes to receive. (00: 256 bytes; 01 to FF: 1 to 255 bytes) When bits 12 to 15 of DM 6648 set to 1: Sets the end code. (00 to FF)																																																																
Peripheral Port Communications Settings The following settings are effective after transfer to the PLC. If CPU Board Communications Switch SW202 is ON, communications through the peripheral port are governed by the default settings (all 0) regardless of the settings in DM 6650 through DM 6654. Communications through the peripheral port are governed by the Programming Console protocol if Communications Switch SW201 is OFF.																																																																		
DM 6650	00 to 03	Port settings 00: Standard (1 start bit, 7 data bits, even parity, 2 stop bits, 9,600 bps, Host Link unit number: 0) 01: Settings in DM 6651 (Any other setting specifies standard settings, causes a non-fatal error, and turns ON AR 1302.)																																																																
	04 to 11	Not used.																																																																
	12 to 15	Communications mode 0: Host Link or peripheral bus; 1: No-protocol (Any other setting specifies Host Link, causes a non-fatal error, and turns ON AR 1302.)																																																																

Word(s)	Bit(s)	Function																																																																
DM 6651	00 to 07	Baud rate 00: 1,200 bps; 01: 2,400 bps; 02: 4,800 bps; 03: 9,600 bps; 04: 19,200 bps																																																																
	08 to 15	<p>Frame format</p> <table border="1"> <thead> <tr> <th></th> <th>Start bits</th> <th>Data bits</th> <th>Stop bits</th> <th>Parity</th> </tr> </thead> <tbody> <tr> <td>00:</td> <td>1 bit</td> <td>7 bits</td> <td>1 bit</td> <td>Even</td> </tr> <tr> <td>01:</td> <td>1 bit</td> <td>7 bits</td> <td>1 bit</td> <td>Odd</td> </tr> <tr> <td>02:</td> <td>1 bit</td> <td>7 bits</td> <td>1 bit</td> <td>None</td> </tr> <tr> <td>03:</td> <td>1 bit</td> <td>7 bits</td> <td>2 bits</td> <td>Even</td> </tr> <tr> <td>04:</td> <td>1 bit</td> <td>7 bits</td> <td>2 bits</td> <td>Odd</td> </tr> <tr> <td>05:</td> <td>1 bit</td> <td>7 bits</td> <td>2 bits</td> <td>None</td> </tr> <tr> <td>06:</td> <td>1 bit</td> <td>8 bits</td> <td>1 bit</td> <td>Even</td> </tr> <tr> <td>07:</td> <td>1 bit</td> <td>8 bits</td> <td>1 bit</td> <td>Odd</td> </tr> <tr> <td>08:</td> <td>1 bit</td> <td>8 bits</td> <td>1 bit</td> <td>None</td> </tr> <tr> <td>09:</td> <td>1 bit</td> <td>8 bits</td> <td>2 bits</td> <td>Even</td> </tr> <tr> <td>10:</td> <td>1 bit</td> <td>8 bits</td> <td>2 bits</td> <td>Odd</td> </tr> <tr> <td>11:</td> <td>1 bit</td> <td>8 bits</td> <td>2 bits</td> <td>None</td> </tr> </tbody> </table> <p>(Any other setting specifies standard settings (1 start bit, 7 data bits; even parity, 2 stop bits), causes a non-fatal error, and turns ON AR 1302.)</p>		Start bits	Data bits	Stop bits	Parity	00:	1 bit	7 bits	1 bit	Even	01:	1 bit	7 bits	1 bit	Odd	02:	1 bit	7 bits	1 bit	None	03:	1 bit	7 bits	2 bits	Even	04:	1 bit	7 bits	2 bits	Odd	05:	1 bit	7 bits	2 bits	None	06:	1 bit	8 bits	1 bit	Even	07:	1 bit	8 bits	1 bit	Odd	08:	1 bit	8 bits	1 bit	None	09:	1 bit	8 bits	2 bits	Even	10:	1 bit	8 bits	2 bits	Odd	11:	1 bit	8 bits	2 bits
	Start bits	Data bits	Stop bits	Parity																																																														
00:	1 bit	7 bits	1 bit	Even																																																														
01:	1 bit	7 bits	1 bit	Odd																																																														
02:	1 bit	7 bits	1 bit	None																																																														
03:	1 bit	7 bits	2 bits	Even																																																														
04:	1 bit	7 bits	2 bits	Odd																																																														
05:	1 bit	7 bits	2 bits	None																																																														
06:	1 bit	8 bits	1 bit	Even																																																														
07:	1 bit	8 bits	1 bit	Odd																																																														
08:	1 bit	8 bits	1 bit	None																																																														
09:	1 bit	8 bits	2 bits	Even																																																														
10:	1 bit	8 bits	2 bits	Odd																																																														
11:	1 bit	8 bits	2 bits	None																																																														
DM 6652	00 to 15	Transmission delay (0000 to 9999 BCD sets a delay of 0 to 99,990 ms.) (Any other setting specifies a delay of 0 ms, causes a non-fatal error, and turns ON AR 1302.)																																																																
DM 6653	00 to 07	Node number (Host Link) 00 to 31 (BCD) (Any other setting specifies a node number of 00, causes a non-fatal error, and turns ON AR 1302.)																																																																
	08 to 11	Start code selection for no-protocol communications 0: Disables start code; 1: Enables start code in DM 6654 (Any other setting disables the start code, causes a non-fatal error, and turns ON AR 1302.)																																																																
	12 to 15	End code selection for no-protocol communications 0: Disables end code; 1: Enables end code in DM 6654; 2: Sets end code of CR, LF. (Any other setting disables the end code, causes a non-fatal error, and turns ON AR 1302.)																																																																
DM 6654	00 to 07	Start code (00 to FF) (This setting is valid only when bits 8 to 11 of DM 6653 are set to 1.)																																																																
	08 to 15	When bits 12 to 15 of DM 6653 set to 0: Sets the number of bytes to receive. (00: 256 bytes; 01 to FF: 1 to 255 bytes) When bits 12 to 15 of DM 6653 set to 1: Sets the end code. (00 to FF)																																																																
Error Log Settings (DM 6655)																																																																		
The following settings are effective after transfer to the PLC.																																																																		
DM 6655	00 to 03	Style 0: Shift after 7 records have been stored 1: Store only first 7 records (no shifting) 2 to F: Do not store records																																																																
	04 to 07	Not used.																																																																
	08 to 11	Cycle time monitor enable 0: Generate a non-fatal error for a cycle time that is too long. 1: Do not generate a non-fatal error.																																																																
	12 to 15	Low battery error enable 0: Generate a non-fatal error for low battery voltage. 1: Do not generate a non-fatal error. Low battery error detection is disabled (i.e., set to 1) by default in CPU Boards that do not have a clock. If the PLC Setup is cleared, the setting will be changed to 0 and a low battery error will occur.																																																																

4-6 Error Log

The error log function registers the error code of any fatal or non-fatal error that occurs in the PLC. The date and time at which the error occurred are registered along with the error code. The error code is also stored in AR 253.

The error log is stored in DM 2000 through DM 2021. Up to 7 error records can be stored.

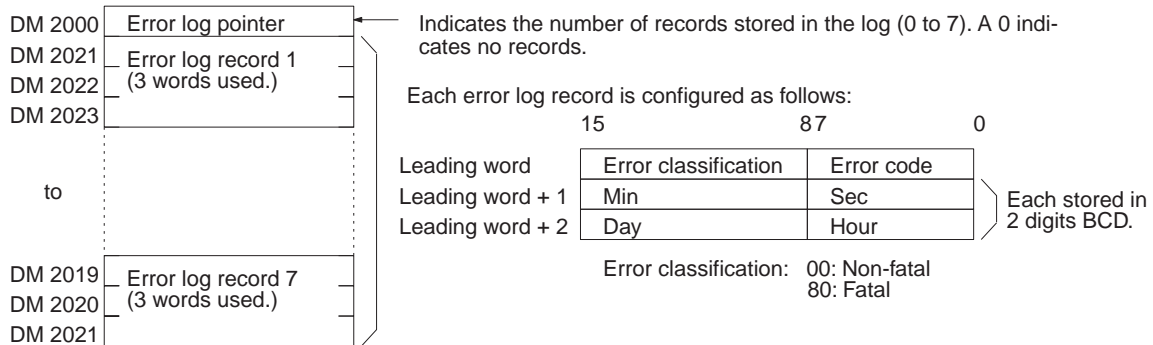

- Note**
1. An error record with an error code of 00 will be stored in the error log for power interruptions. Refer to 8-3 *Self-diagnostic Functions* for tables listing error codes.
 2. In CPU Boards without a clock, the time that the error occurred will be set to all zeroes.

Error Log Storage Methods

The error log storage method is set in the PLC Setup (bits 00 to 03 of DM 6655). Set any of the following methods.

- 1,2,3...**
1. DM 6655 bits 00 to 03 set to 0:
Stores the most recent 7 error log records and discard older records. This is achieved by shifting the records as shown below so that the oldest record (record 0) is lost whenever a new record is generated.

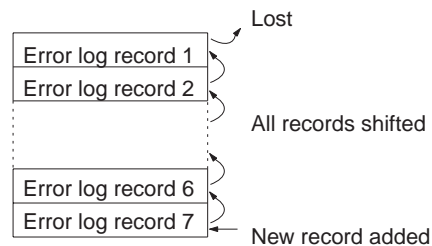

2. DM 6655 bits 00 to 03 set to 1:
Stores only the first 7 error log records, and ignores any subsequent errors beyond those 7.
3. DM 6655 bits 00 to 03 set to any value other than 0 or 1:
Disables the log so that no records are stored.

The default setting is the first method. Refer to the preceding page for details on the error log settings in DM 6655.

Clearing the Error Log

To clear the entire error log, turn ON SR 25214 from a Programming Device. (After the error log has been cleared, SR 25214 will turn OFF again automatically.)

SECTION 5

Instruction Set

The CPM2B PLCs have a large programming instruction set that allows for easy programming of complicated control processes. This section provides a brief summary of the instruction set.

5-1	CPM2B Function Codes	90
5-2	Alphabetic List by Mnemonic	91
5-3	Expansion Instructions	94

5-1 CPM2B Function Codes

The following table lists the CPM2B instructions that have fixed function codes. Each instruction is listed by mnemonic and by instruction name. Use the numbers in the leftmost column as the left digit and the number in the column heading as the right digit of the function code.

Left digit	Right digit									
	0	1	2	3	4	5	6	7	8	9
0	NOP NO OPERATION	END END	IL INTERLOCK	ILC INTERLOCK CLEAR	JMP JUMP	JME JUMP END	(@) FAL FAILURE ALARM AND RESET	FALS SEVERE FAILURE ALARM	STEP STEP DEFINE	SNXT STEP START
1	SFT SHIFT REGISTER	KEEP KEEP	CNTR REVERSIBLE COUNTER	DIFU DIFFERENTIATE UP	DIFD DIFFERENTIATE DOWN	TIMH HIGH-SPEED TIMER	(@) WSFT WORD SHIFT	(@) ASFT ASYNCHRONOUS SHIFT REGISTER	---	---
2	CMP COMPARE	(@) MOV MOVE	(@) MVN MOVE NOT	(@) BIN BCD TO BINARY	(@) BCD BINARY TO BCD	(@) ASL SHIFT LEFT	(@) ASR SHIFT RIGHT	(@) ROL ROTATE LEFT	(@) ROR ROTATE RIGHT	(@) COM COMMENT
3	(@) ADD BCD ADD	(@) SUB BCD SUBTRACT	(@) MUL BCD MULTIPLY	(@) DIV BCD DIVIDE	(@) ANDW LOGICAL AND	(@) ORW LOGICAL OR	(@) XORW EXCLUSIVE OR	(@) XNRW EXCLUSIVE NOR	(@) INC INCREMENT	(@) DEC DECREMENT
4	(@) STC SET CARRY	(@) CLC CLEAR CARRY	---	---	---	---	(@) MSG MESSAGE DISPLAY	(@) RXD RECEIVE	(@) TXD TRANSMIT	---
5	(@) ADB BINARY ADD	(@) SBB BINARY SUBTRACT	(@) MLB BINARY MULTIPLY	(@) DVB BINARY DIVIDE	(@) ADDL DOUBLE BCD ADD	(@) SUBL DOUBLE BCD SUBTRACT	(@) MULL DOUBLE BCD MULTIPLY	(@) DIVL DOUBLE BCD DIVIDE	(@) BINL DOUBLE BCD-TO-DOUBLE BINARY	(@) BCDL DOUBLE BINARY-TO-DOUBLE BCD
6	CMPL DOUBLE COMPARE	(@) INI MODE CONTROL	(@) PRV HIGH-SPEED COUNTER PV READ	(@) CTBL COMPARISON TABLE LOAD	(@) SPED SPEED OUTPUT	(@) PULS SET PULSES	(@) SCL SCALING	(@) BCNT BIT COUNTER	(@) BCMP BLOCK COMPARE	(@) STIM INTERVAL TIMER
7	(@) XFER BLOCK TRANSFER	(@) BSET BLOCK SET	---	(@) XCHG DATA EXCHANGE	(@) SLD ONE DIGIT SHIFT LEFT	(@) SRD ONE DIGIT SHIFT RIGHT	(@) MLPX 4-TO-16 DECODER	(@) DMPX 16-TO-4 ENCODER	(@) SDEC 7-SEGMENT DECODER	---
8	(@) DIST SINGLE WORD DISTRIBUTE	(@) COLL DATA COLLECT	(@) MOV B MOVE BIT	(@) MOV D MOVE DIGIT	(@) SFTR REVERSIBLE SHIFT REGISTER	(@) TCMP TABLE COMPARE	(@) ASC ASCII CONVERT	---	---	(@) INT INTERRUPT CONTROL
9	---	(@) SBS SUBROUTINE ENTRY	SBN SUBROUTINE DEFINE	RET SUBROUTINE RETURN	---	---	---	(@) IORF I/O REFRESH	---	(@) MCRO MACRO

- Note**
1. The shaded areas are function codes to which expansion instructions are allocated by default or to which the user can allocate expansion instructions. Refer to 5-3 *Expansion Instructions* for more details.
 2. Instruction execution times are the same as those for the CPM2A and CPM2C. Refer to the *Programming Manual (W353)* for details.

5-2 Alphabetic List by Mnemonic

Dashes (“—”) in the *Code* column indicate expansion instructions, which do not have fixed function codes. “None” indicates instructions for which function codes are not used.

Mnemonic	Code	Words	Name
ACC (@)	—	4	ACCELERATION CONTROL
ADB (@)	50	4	BINARY ADD
ADD (@)	30	4	BCD ADD
ADDL (@)	54	4	DOUBLE BCD ADD
AND	None	1	AND
AND LD	None	1	AND LOAD
AND NOT	None	1	AND NOT
ANDW (@)	34	4	LOGICAL AND
ASC (@)	86	4	ASCII CONVERT
ASFT (@)	17	4	ASYNCHRONOUS SHIFT REGISTER
ASL (@)	25	2	ARITHMETIC SHIFT LEFT
ASR (@)	26	2	ARITHMETIC SHIFT RIGHT
AVG	—	4	AVERAGE VALUE
BCD (@)	24	3	BINARY TO BCD
BCDL (@)	59	3	DOUBLE BINARY-TO-DOUBLE BCD
BCMP (@)	68	4	BLOCK COMPARE
BCNT (@)	67	4	BIT COUNTER
BIN (@)	23	3	BCD-TO-BINARY
BINL (@)	58	3	DOUBLE BCD-TO-DOUBLE BINARY
BSET (@)	71	4	BLOCK SET
CLC (@)	41	1	CLEAR CARRY
CMP	20	3	COMPARE
CMPL	60	4	DOUBLE COMPARE
CNT	None	2	COUNTER
CNTR	12	3	REVERSIBLE COUNTER
COLL (@)	81	4	DATA COLLECT
COM (@)	29	2	COMPLEMENT
CTBL (@)	63	4	COMPARISON TABLE LOAD
DEC (@)	39	2	BCD DECREMENT
DIFD	14	2	DIFFERENTIATE DOWN
DIFU	13	2	DIFFERENTIATE UP
DIST (@)	80	4	SINGLE WORD DISTRIBUTE
DIV (@)	33	4	BCD DIVIDE
DIVL (@)	57	4	DOUBLE BCD DIVIDE
DMPX (@)	77	4	16-TO-4 ENCODER
DVB (@)	53	4	BINARY DIVIDE
END	01	1	END
FAL (@)	06	2	FAILURE ALARM AND RESET
FALS	07	2	SEVERE FAILURE ALARM
FCS (@)	—	4	FCS CALCULATE
HEX (@)	—	4	ASCII-TO-HEXADECIMAL
HMS	—	4	SECONDS TO HOURS
IL	02	1	INTERLOCK
ILC	03	1	INTERLOCK CLEAR

Mnemonic	Code	Words	Name
INC (@)	38	2	INCREMENT
INI (@)	61	4	MODE CONTROL
INT (@)	89	4	INTERRUPT CONTROL
IORF (@)	97	3	I/O REFRESH
JME	05	2	JUMP END
JMP	04	2	JUMP
KEEP	11	2	KEEP
LD	None	1	LOAD
LD NOT	None	1	LOAD NOT
MAX (@)	—	4	FIND MAXIMUM
MCRO (@)	99	4	MACRO
MIN (@)	—	4	FIND MINIMUM
MLB (@)	52	4	BINARY MULTIPLY
MLPX (@)	76	4	4-TO-16 DECODER
MOV (@)	21	3	MOVE
MOVB (@)	82	4	MOVE BIT
MOVD (@)	83	4	MOVE DIGIT
MSG (@)	46	2	MESSAGE
MUL (@)	32	4	BCD MULTIPLY
MULL (@)	56	4	DOUBLE BCD MULTIPLY
MVN (@)	22	3	MOVE NOT
NEG (@)	—	4	2'S COMPLEMENT
NOP	00	1	NO OPERATION
OR	None	1	OR
OR LD	None	1	OR LOAD
OR NOT	None	1	OR NOT
ORW (@)	35	4	LOGICAL OR
OUT	None	2	OUTPUT
OUT NOT	None	2	OUTPUT NOT
PID	—	4	PID CONTROL
PRV (@)	62	4	HIGH-SPEED COUNTER PV READ
PULS (@)	65	4	SET PULSES
PWM (@)	—	4	PULSE WITH VARIABLE DUTY RATIO
RET	93	1	SUBROUTINE RETURN
ROL (@)	27	2	ROTATE LEFT
ROR (@)	28	2	ROTATE RIGHT
RSET	None	2	RESET
RXD (@)	47	4	RECEIVE
SBB (@)	51	4	BINARY SUBTRACT
SBN	92	2	SUBROUTINE DEFINE
SBS (@)	91	2	SUBROUTINE ENTRY
SCL (@)	66	4	SCALING
SCL2 (@)	—	4	SIGNED BINARY TO BCD SCALING
SCL3 (@)	—	4	BCD TO SIGNED BINARY SCALING
SDEC (@)	78	4	7-SEGMENT DECODER
SEC	—	4	HOURS TO SECONDS
SET	None	2	SET
SFT	10	3	SHIFT REGISTER
SFTR (@)	84	4	REVERSIBLE SHIFT REGISTER

Mnemonic	Code	Words	Name
SLD (@)	74	3	ONE DIGIT SHIFT LEFT
SNXT	09	2	STEP START
SPED (@)	64	4	SPEED OUTPUT
SRCH (@)	—	4	DATA SEARCH
SRD (@)	75	3	ONE DIGIT SHIFT RIGHT
STC (@)	40	1	SET CARRY
STEP	08	2	STEP DEFINE
STIM (@)	69	4	INTERVAL TIMER
STUP	—	3	CHANGE RS-232C SETUP
SUB (@)	31	4	BCD SUBTRACT
SUBL (@)	55	4	DOUBLE BCD SUBTRACT
SUM (@)	—	4	SUM
SYNC (@)	—	4	SYNCHRONIZED PULSE CONTROL
TCMP (@)	85	4	TABLE COMPARE
TIM	None	2	TIMER
TIMH	15	3	HIGH-SPEED TIMER
TIML	—	4	LONG TIMER
TMHH	—	4	VERY HIGH-SPEED TIMER
TXD (@)	48	4	TRANSMIT
WSFT (@)	16	3	WORD SHIFT
XCHG (@)	73	3	DATA EXCHANGE
XFER (@)	70	4	BLOCK TRANSFER
XNRW (@)	37	4	EXCLUSIVE NOR
XORW (@)	36	4	EXCLUSIVE OR
ZCP	—	4	AREA RANGE COMPARE
ZCPL	—	4	DOUBLE AREA RANGE COMPARE

5-3 Expansion Instructions

A set of expansion instructions is provided to aid in special programming needs. Function codes can be assigned to up to 18 of the expansion instructions to enable using them in programs. This allows the user to pick the instructions needed by each program to more effectively use the function codes required to input instructions.

The mnemonics of expansion instructions are followed by “(—)” as the function code to indicate that they must be assigned function codes by the user in the instructions table before they can be used in programming (unless they are used under their default settings).

Refer to the *7-2-7 Assigning Expansion Instruction Function Codes* for a description of the Programming Console operations used to change expansion instruction allocations.

Refer to the *SYSMAC Support Software Operation Manuals: C-series PLCs (W248)*, the *SYSMAC-CPT Support Software User Manual (W333)*, or the *WS02-CXP□□-E CX-Programmer Operation Manual (W414)* for a description of the corresponding Support Software operations.

Function Codes for Expansion Instructions

The following 18 function codes can be used for expansion instructions: 17, 18, 19, 47, 48, 60, 61, 62, 63, 64, 65, 66, 67, 68, 69, 87, 88, and 89

The 35 expansion instructions that can be used are listed below, along with the default function codes that are assigned when the CPM2B is shipped.

Mnemonic	Code
ASFT (@)	17
(open)	18
(open)	19
RXD (@)	47
TXD (@)	48
CMPL	60
INI (@)	61
PRV (@)	62
CTBL (@)	63
SPED (@)	64
PULS (@)	65
SCL (@)	66
BCNT (@)	67

Mnemonic	Code
BCMP (@)	68
STIM (@)	69
(open)	87
(open)	88
INT (@)	89
ACC (@)	---
AVG	---
FCS (@)	---
HEX (@)	---
HMS (@)	---
MAX (@)	---
MIN (@)	---
NEG (@)	---

Mnemonic	Code
PID	---
PWM (@)	---
SCL2 (@)	---
SCL3 (@)	---
SEC (@)	---
SRCH (@)	---
STUP (@)	---
SUM (@)	---
SYNC (@)	---
TIML	---
TMHH	---
ZCP	---
ZCPL	---

SECTION 6

Using Analog I/O Boards

This section provides an overview of Analog I/O Boards, including specifications, part names, wiring, installation, basic settings, and operations. Information on creating ladder programs is also provided, including programming examples.

6-1	Overview of Analog I/O Boards	96
6-2	Specifications and Part Names	97
6-3	Overview of Operations	103
6-4	Application Procedure	105
6-4-1	Board Assembly	105
6-4-2	DIP Switch Settings	105
6-4-3	Analog I/O Wiring	106
6-4-4	Ladder Programming	111
6-5	Troubleshooting Unit Errors	116

6-1 Overview of Analog I/O Boards

Analog I/O Boards are available in three models, which are the CPM2B-MAD63 (6 analog inputs and 3 analog outputs), the CPM2B-MAD42 (4 analog inputs and 2 analog outputs), and the CPM2B-MAD21 (2 analog inputs and 1 analog output).

Up to three Analog I/O Boards, with a total of 8 inputs and 4 outputs, can be connected to a CPM2B CPU Board.

- Note**
1. The maximum number of Analog I/O Boards that can be connected depends on the model of the Board.
 2. Analog I/O Boards can be connected to CPU Boards with a 24-V DC power supply only.

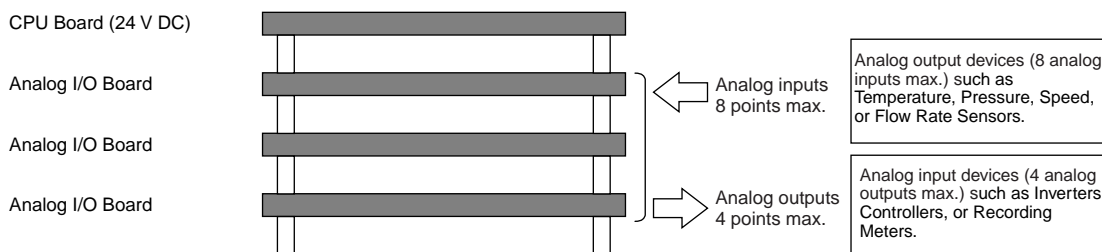

List of Models

Model	Analog input		Analog output		Number of allocated words	Number of Boards
	Input signal range	Number of inputs	Output signal range	Number of outputs		
CPM2B-MAD63	0 to 5 V, 1 to 5 V, 0 to 10 V, -10 to 10 V, 0 to 20 mA, and 4 to 20 mA	6 points	1 to 5 V, 0 to 10 V, -10 to 10 V, 0 to 20 mA, and 4 to 20 mA	3 points	Input: 6 words Output: 3 words	1 max.
CPM2B-MAD42		4 points		2 points	Input: 4 words Output: 2 words	2 max.
CPM2B-MAD21		2 points		1 point	Input: 2 words Output: 1 word	3 max.

Note When two CPM2B-MAD42 Analog I/O Boards are connected, the maximum I/O configuration is 8 inputs and 4 outputs.

Average Processing (Analog Inputs)

A DIP switch setting can be turned ON to activate average processing for analog inputs. Average processing stores the converted data of the average value (moving average) of the last eight inputs. Average processing allows inputs subject to minute fluctuations to be handled as stable inputs. Use pin 2 of the DIP switches to set average processing for each input.

Line Disconnection Detection (Analog Inputs)

If the input signal drops to below 0.8 V or 3.2 mA, respectively, when the input range is set to either 1 to 5 V or 4 to 20 mA, a disconnection of the input line is detected and the line disconnection detection function is activated. When a line disconnection is detected, the conversion data will be 8,000. The time for the line disconnection to be detected, and the time required to clear the error, is the same as the conversion time. When the input returns to a value within the range that can be converted, the line disconnection status is automatically cleared, and normal conversion data is resumed.

6-2 Specifications and Part Names

I/O Specifications

Item		Voltage input/output	Current input/output	
Analog inputs	Input signal range	0 to 5 V, 1 to 5 V, 0 to 10 V, or -10 to 10 V	0 to 20 mA or 4 to 20 mA	
	Maximum rated input	15 V	±30 mA	
	External input impedance	1 MΩ min.	Approx. 250 Ω	
	Resolution	6,000 (full scale)		
	Overall accuracy	25°C	±0.3% (full scale)	±0.4% (full scale)
		0 to 55°C	±0.6% (full scale)	±0.8% (full scale)
	A/D conversion data	Binary data (4-digit hexadecimal) -10 to 10 V: Full scale F448 to 0BB8 (hex) Other ranges: Full scale 0000 to 1770 (hex)		
	Average processing	Yes (Set each input using DIP switch 2.)		
Disconnection detection	Yes			
Analog outputs	Output signal range	1 to 5 V, 0 to 10 V, or -10 to 10 V	0 to 20 mA or 4 to 20 mA	
	External output allowable load resistance	1 kΩ min.	600 Ω max.	
	External output impedance	0.5 Ω max.	---	
	Resolution	6,000 (full scale)		
	Overall accuracy	25°C	±0.4% (full scale)	
		0 to 55°C	±0.8% (full scale)	
D/A conversion data	Binary data (4-digit hexadecimal) -10 to 10 V: Full scale F448 to 0BB8 (hex) Other ranges: Full scale 0000 to 1770 (hex)			
Conversion time	2 ms/point (10 ms for all points)			
Isolation method	Between analog I/O and internal circuits: Photocoupler isolation (No isolation between analog inputs.)			

The general specifications for the Analog I/O Board conform to those of the CPM2B CPU Unit.

Analog Input Signal Ranges

-10 to 10 V

The voltage range -10 to 10 V corresponds to hexadecimal values F448 to 0BB8 (-3,000 to 3,300 decimal). Negative voltages are expressed as two's complements.

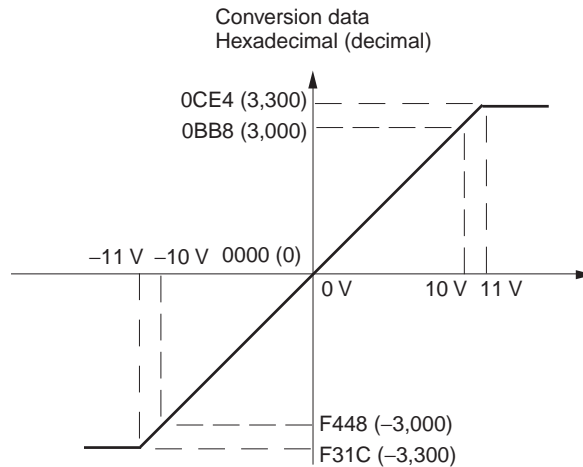

0 to 10 V

The voltage range 0 to 10 V corresponds to hexadecimal values 0000 to 1770 (0 to 6,000 decimal). The range of data that can be converted is FED4 to 189C (-300 to 6,300 decimal). Negative voltages are expressed as two's complements.

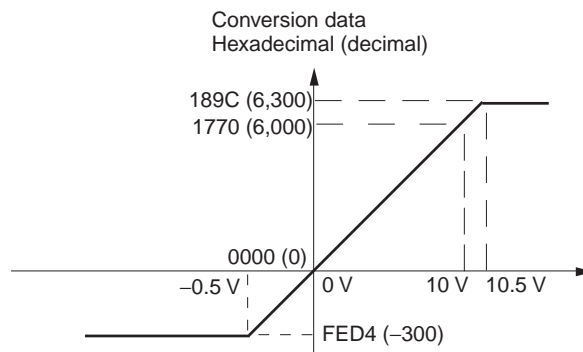

0 to 5 V

The voltage range 0 to 5 V corresponds to hexadecimal values 0000 to 1770 (0 to 6,000 decimal). The range of data that can be converted is FED4 to 189C (-300 to 6,300 decimal). Negative voltages are expressed as two's complements.

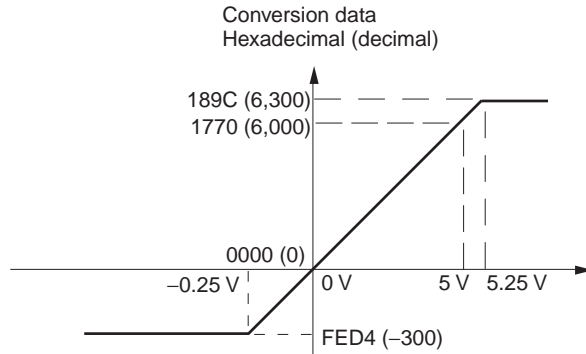

1 to 5 V

The voltage range 1 to 5 V corresponds to hexadecimal values 0000 to 1770 (0 to 6,000 decimal). The range of data that can be converted is FED4 to 189C (-300 to 6,300 decimal). Inputs of 0.8 to 1 V are expressed as two's complements. If the input level drops below the input range (input is less than 0.8 V), a line disconnection will be detected, and the data will be returned as 8,000.

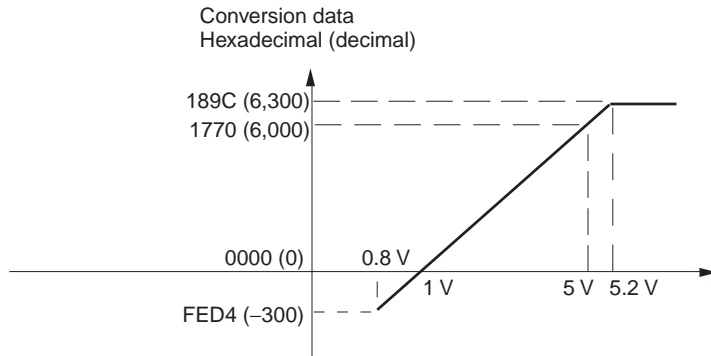

0 to 20 mA

The current range 0 to 20 mA corresponds to hexadecimal values 0000 to 1770 (0 to 6,000 decimal). The range of data that can be converted is FED4 to 189C (-300 to 6,300 decimal). Negative voltages are expressed as two's complements.

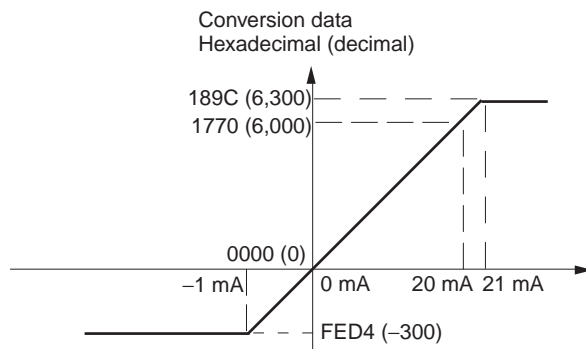

4 to 20 mA

The current range 4 to 20 mA corresponds to hexadecimal values 0000 to 1770 (0 to 6,000 decimal). The range of data that can be converted is FED4 to 189C (-300 to 6,300 decimal). Negative voltages are expressed as two's complements. Inputs of 3.2 to 4 mA are expressed as two's complements. When the input level drops below the input range (input is less than 3.2 mA), a line disconnection is detected, and the data is returned as 8,000.

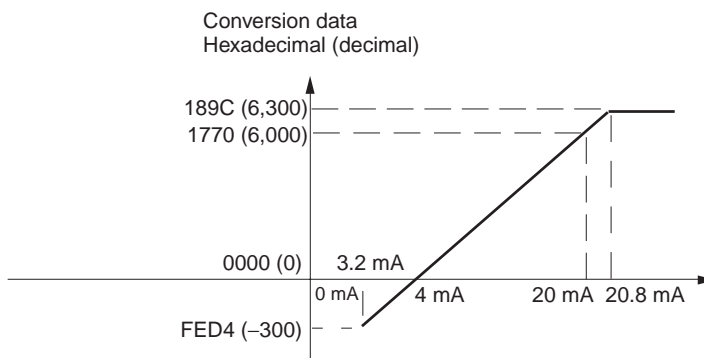

Analog Output Signal Ranges

-10 to 10 V

Hexadecimal values F448 to 0BB8 (-3,000 to 3,300 decimal) correspond to the voltage range -10 to 10 V. The output range is -11 to 11 V. When outputting negative values, specify the DA conversion data as its two's complement.

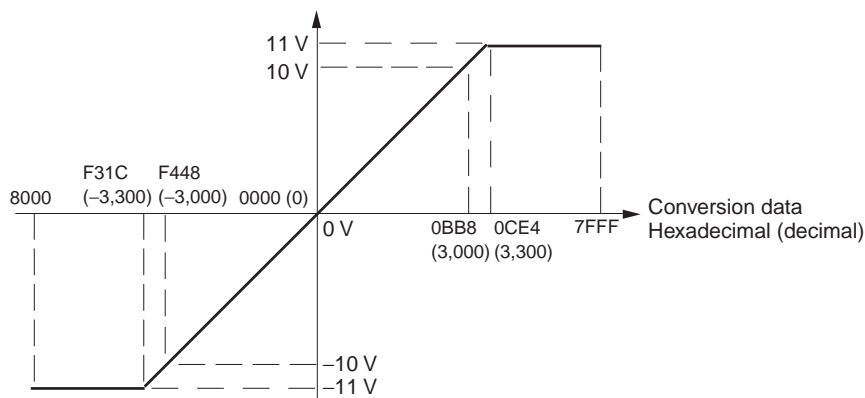

0 to 10 V

Hexadecimal values 0000 to 1770 (0 to 6,000 decimal) correspond to the voltage range 0 to 10 V. The output range is -0.5 to 10.5 V. When outputting negative values, specify the DA conversion data as its two's complement.

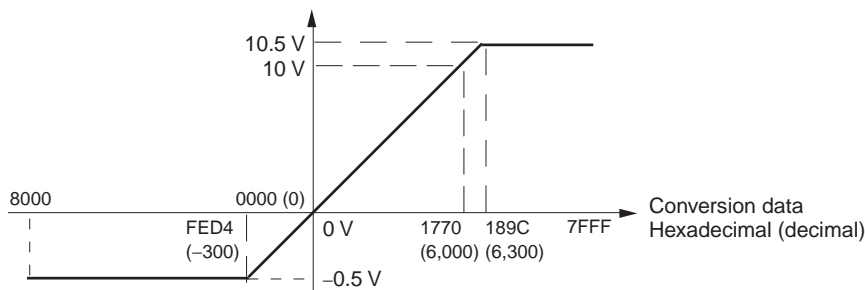

1 to 5 V

Hexadecimal values 0000 to 1770 (0 to 6,000 decimal) correspond to the voltage range 1 to 5 V. The output range is -0.8 to 5.2 V.

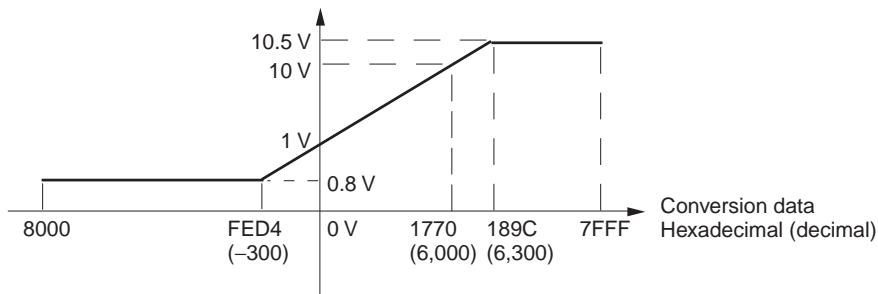

0 to 20 mA

Hexadecimal values 0000 to 1770 (0 to 6,000 decimal) correspond to the current range 0 to 20 mA. The output range is 0 to 21 mA.

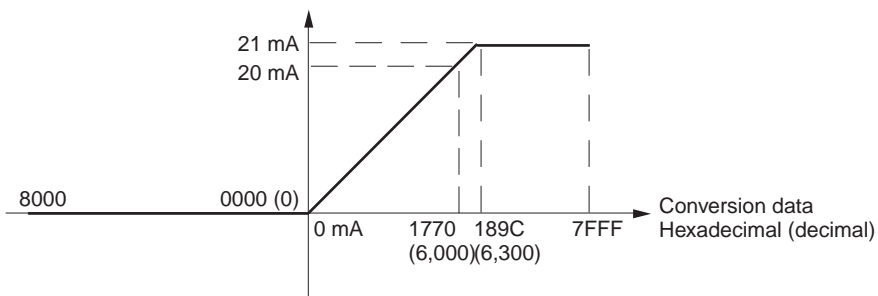

4 to 20 mA

Hexadecimal values 0000 to 1770 (0 to 6,000 decimal) correspond to the current range 4 to 20 mA. The output range is 3.2 to 20.8 mA.

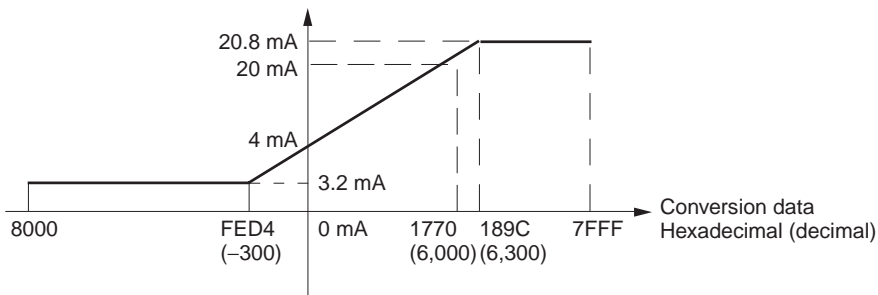

Part Names

CPM2B-MAD21, CPM2B-MAD42, and CPM2B-MAD63 Analog I/O Boards

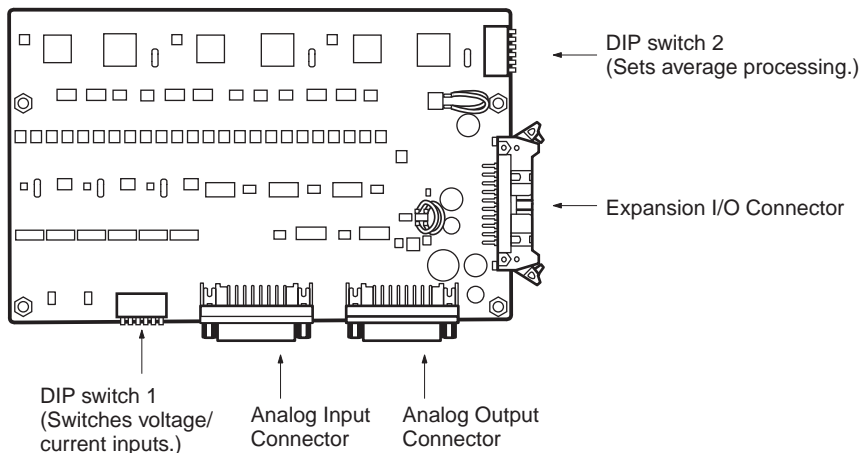

Analog Input Connector

Inputs analog input (voltage/current) signals from external devices. Use the connector provided when wiring. (Refer to 6-4-3 *Analog I/O Wiring* for details.)

Analog Output Connector

Outputs analog input (voltage/current) signals to external devices. Use the connector provided when wiring. (Refer to 6-4-3 *Analog I/O Wiring* for details.)

DIP Switch 1: Analog Output/Current Switch

Switches between analog voltage input and analog current input. Always turn OFF the corresponding pin of DIP switch 1 when using a voltage input. (Refer to 6-4-2 *DIP Switch Settings* for details.)

DIP Switch 2: Analog Input Average Processing Switch

Set when performing average processing of analog inputs. (Refer to 6-4-2 *DIP Switch Settings* for details.)

Expansion I/O Connector

Connect to the CPU Board or Expansion I/O Board.

6-3 Overview of Operations

Analog I/O Boards convert analog signals (voltage/current) into 4-digit hexadecimal data, according to the set range code. They are also used to convert output data (4-digit hexadecimal) into analog voltage/current signals and output to external devices. Ladder programming is used to set the range code, read the input conversion data, and set the output data.

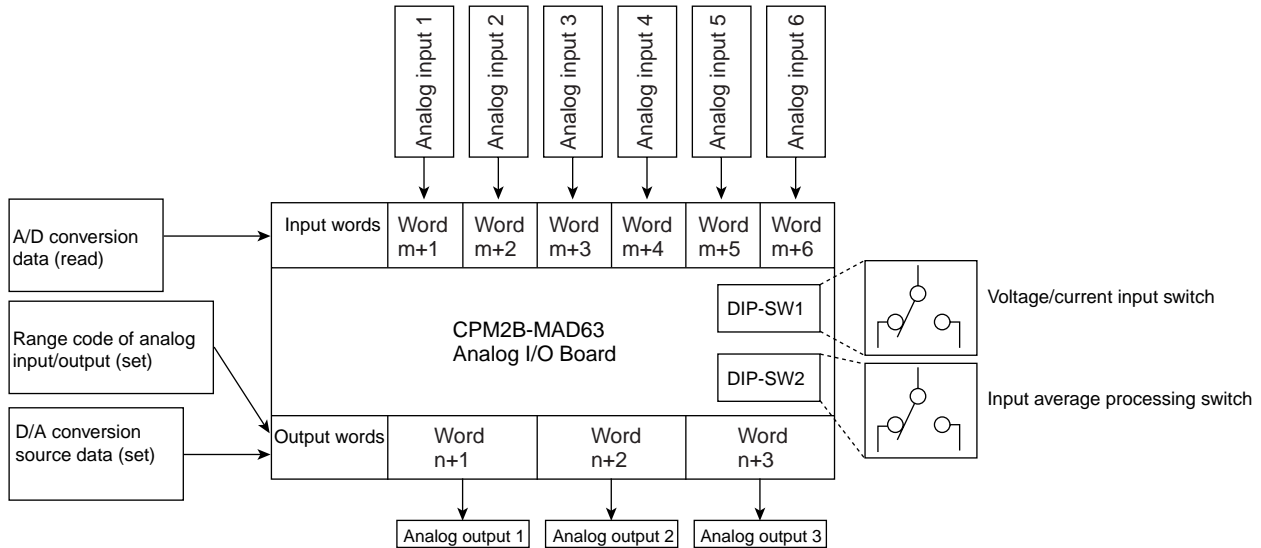

Setting I/O Range Codes

The I/O range code is set individually for each analog output or input. The settings are made by writing the following range codes from the ladder program to the output words allocated to the Analog I/O Board.

Range code	Analog input signal range	Analog output signal range
000	-10 to 10 V	-10 to 10 V
001	0 to 10 V	0 to 10 V
010	1 to 5 V or 4 to 20 mA (See notes 1 and 2.)	1 to 5 V
011	0 to 5 V or 0 to 20 mA (See note 1.)	0 to 20 mA
100	---	4 to 20 mA

- Note**
1. Use DIP switch 1 to switch between a voltage current analog input.
 2. When the analog input signal range is 1 to 5 V or 4 to 20 mA, line disconnection detection will function.
 3. The range code is set for each input and output.

Words Allocated to Analog I/O Board

Analog I/O Boards are allocated I/O words following those allocated to the CPU Board or the previously connected Expansion Board.

Model	Input words	Output words
CPM2B-MAD63	Words m+1 to m+6 (6 words)	Words n+1 to n+3 (3 words)
CPM2B-MAD42	Words m+1 to m+4 (4 words)	Words n+1 to n+2 (2 words)
CPM2B-MAD21	Words m+1 to m+2 (2 words)	Word n+1 (1 word)

m: The last input word allocated to the CPU Board or to the previous Board if one is already connected.

n: The last output word allocated to the CPU Board or to the previous Board if one is already connected.

Starting A/D or D/A Conversion

- Conversion processing cannot start until the range code is set. Until the range code is set, the input (A/D conversion) data will be 0000 and the D/A conversion output will be 0 V or 0 mA.
- When the range code is set, A/D conversion or D/A conversion processing will start. After turning ON the power to the Analog I/O Board, the first data is stored in the input words, which requires approximately two cycles plus 50 ms. When starting operation at the same time as the power is turned ON, use a timer instruction (TIM) and delay executing programming for the Analog I/O Board by between 100 and 200 ms. (Refer to the ladder programming example in 6-4-4 Ladder Programming.)
- After the range code has been set, the minimum values for each range will be output until the D/A-convertible output data is set.
- The range code that has been set cannot be changed during communications. To change the range code, turn OFF the power and then turn it ON again before resetting the range code.

Reading Input Data (A/D Conversion Data)

Input data is stored as 4-digit hexadecimal values in the input words allocated to the Analog I/O Board. If an input signal drops below the minimum value of the conversion range, the minimum value will be stored. If the signal exceeds the maximum value of the conversion range, the maximum value will be stored in the input word.

Input word	CPM2B-MAD63	CPM2B-MAD42	CPM2B-MAD21
Word m+1	Input data 1 (Analog input 1)	Input data 1 (Analog input 1)	Input data 1 (Analog input 1)
Word m+2	Input data 2 (Analog input 2)	Input data 2 (Analog input 2)	Input data 2 (Analog input 2)
Word m+3	Input data 3 (Analog input 3)	Input data 3 (Analog input 3)	---
Word m+4	Input data 4 (Analog input 4)	Input data 4 (Analog input 4)	
Word m+5	Input data 5 (Analog input 5)	---	
Word m+6	Input data 6 (Analog input 6)	---	

Setting Output Data (D/A Conversion Source Data)

When 4-digit hexadecimal data is set in the output words allocated to the Analog I/O Board, D/A conversion is performed and the analog voltage/current signals are output to the external devices. If the set value is below the conversion range, the minimum value will be written to the output word. If the set value exceeds the maximum value of the conversion range, the maximum value will be written to the output word.

Output words	CPM2B-MAD63	CPM2B-MAD42	CPM2B-MAD21
Word n+1	Output data 1 (Analog output 1)	Output data 1 (Analog output 1)	Output data 1 (Analog output 1)
Word n+2	Output data 2 (Analog output 2)	Output data 2 (Analog output 2)	---
Word n+3	Output data 3 (Analog output 3)	---	

6-4 Application Procedure

The information provided here is based on a configuration with a single Expansion I/O Board with 32 inputs/outputs and a single CPM2B-MAD63 Analog I/O Board connected to a CPU Board with 40 inputs/outputs. The analog I/O specifications are as follows:

Analog input or output	I/O range	Range code	Switching voltage/current input		Average processing (DIP switch 2 setting)
			DIP switch 1 setting	Wiring	
Analog input 1	4 to 20 mA	010	ON	Wire the positive (+) and negative (-) terminal for each input.	Not used. (OFF)
Analog input 2	4 to 20 mA	010	ON		Not used. (OFF)
Analog input 3	-10 to 10 V	000	OFF		Used (ON)
Analog input 4	0 to 10 V	001	OFF		Not used. (OFF)
Analog input 5	0 to 5 V	011	OFF		Not used. (OFF)
Analog input 6	Not used.	--- (Disabled.)	OFF (Disabled.)	Short-circuit the positive (+) and negative (-) terminals for the input.	OFF (Disabled.)
Analog output 1	4 to 20 mA	010	---	Wire the current output terminal and the output COM terminal.	
Analog output 2	4 to 20 mA	010	---		
Analog output 3	0 to 10 V	001	---	Wire the voltage output terminal and the output COM terminal.	

6-4-1 Board Assembly

The CPU Board, Expansion I/O Board, and Analog I/O Board are assembled as shown in the following diagram.

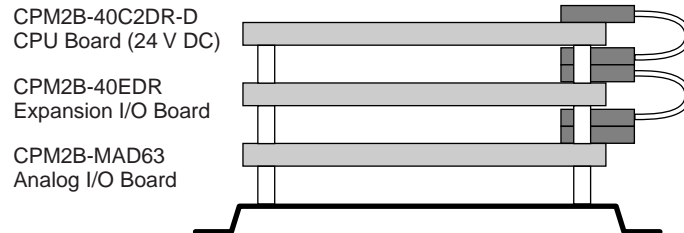

For details on Board installation and connecting the Expansion Board connector, refer to *SECTION 3 Installation and Wiring*.

6-4-2 DIP Switch Settings

- Note**
1. Always turn OFF the voltage/current input switch when using a voltage input.
 2. Turn OFF the power before setting DIP switches to prevent malfunctions caused by static electricity.

Voltage/Current Input Switch (DIP Switch 1)

When using either a current input of 4 to 20 mA (range code 010) or 0 to 20 mA (range code 011), turn ON (bottom) the pin of DIP switch 1 for the corresponding input.

Pin	1	2	3	4	5	6
CPM2B-MAD63	Input 1	Input 2	Input 3	Input 4	Input 5	Input 6
CPM2B-MAD42	Input 1	Input 2	Input 3	Input 4	Not available.	
CPM2B-MAD21	Input 1	Input 2	Not available.			

Here, analog inputs 1 and 2 use current inputs (4 to 20 mA), so pins 1 and 2 are turned ON (bottom).

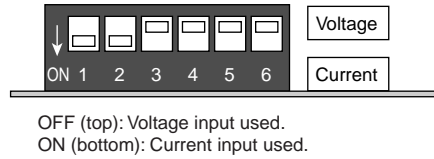

Note When a voltage input is used, always turn OFF the corresponding pin of DIP switch 1, even if the range code is set to a value other than 010 or 011.

Average Processing Switch (DIP Switch 2)

When minute fluctuations occur in an analog input signal, average processing can be used to stabilize the input. With average processing, the average of the previous eight data values is used as the conversion data.

Analog I/O Unit	DIP switch 2 pin					
	1	2	3	4	5	6
CPM2B-MAD63	Input 1	Input 2	Input 3	Input 4	Input 5	Input 6
CPM2B-MAD42	Input 1	Input 2	Input 3	Input 4	Not available.	
CPM2B-MAD21	Input 1	Input 2	Not available.			

Here, average processing is used by analog input 3, so pin 3 is turned ON (bottom).

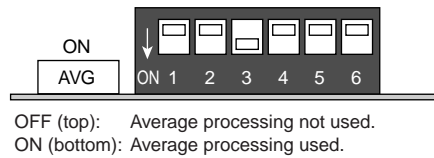

6-4-3 Analog I/O Wiring

Use the connectors provided with the Analog I/O Boards when wiring analog I/O.

CPM2B-MAD21, CPM2B-MAD42, and CPM2B-MAD63 Analog I/O Boards

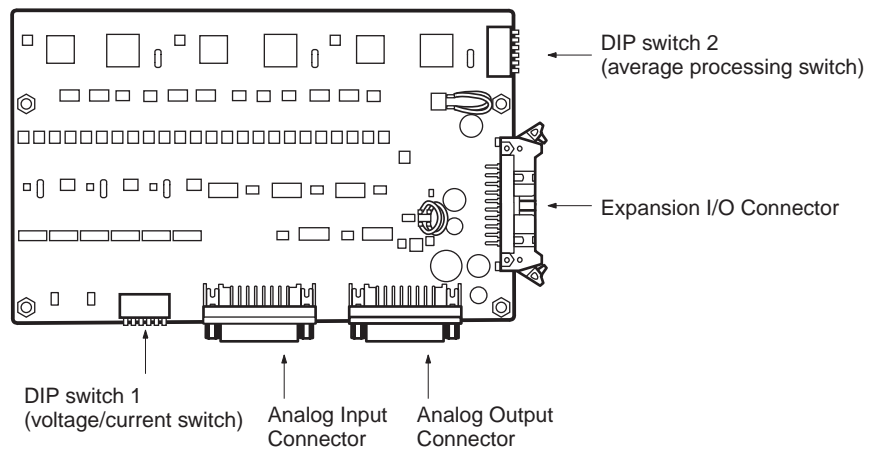

Analog Input Connector Wiring

Connector Pin Arrangement

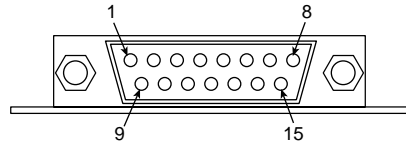

Internal Circuits

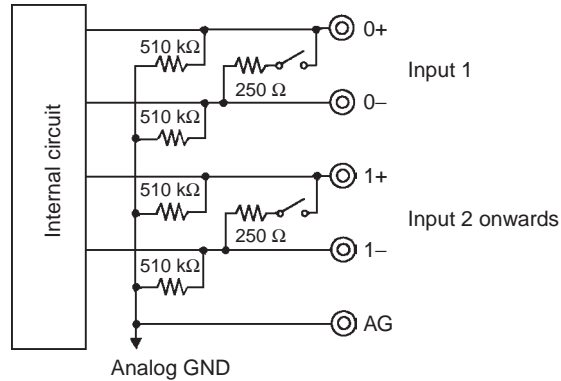

Pin No.	CPM2B-MAD63	CPM2B-MAD42	CPM2B-MAD21
1	Analog input 1 (+)	Analog input 1 (+)	Analog input 1 (+)
2	Analog input 2 (+)	Analog input 2 (+)	Analog input 2 (+)
3	Analog input 3 (+)	Analog input 3 (+)	N.C.
4	Analog input 4 (+)	Analog input 4 (+)	N.C.
5	Analog input 5 (+)	N.C.	N.C.
6	Analog input 6 (+)	N.C.	N.C.
7	N.C.	N.C.	N.C.
8	AG	AG	AG
9	Analog input 1 (-)	Analog input 1 (-)	Analog input 1 (-)
10	Analog input 2 (-)	Analog input 2 (-)	Analog input 2 (-)
11	Analog input 3 (-)	Analog input 3 (-)	N.C.
12	Analog input 4 (-)	Analog input 4 (-)	N.C.
13	Analog input 5 (-)	N.C.	N.C.
14	Analog input 6 (-)	N.C.	N.C.
15	AG	AG	AG

N.C.: Not used.

Analog Input Wiring

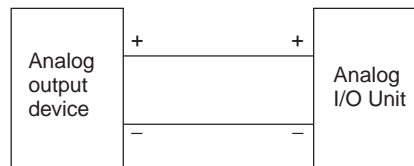

- Note**
1. When using shielded cables, do not connect the shield wire.
 2. Short-circuit the positive (+) and negative (-) input terminals for inputs that are not used.
 3. Lay AC power supply cables and power lines separately.

- If noise interference from the power lines occurs, insert a noise filter in the power supply and input section.

Analog Output Connector Wiring

Connector Pin Arrangement

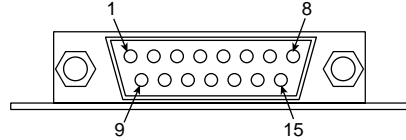

Internal Circuit

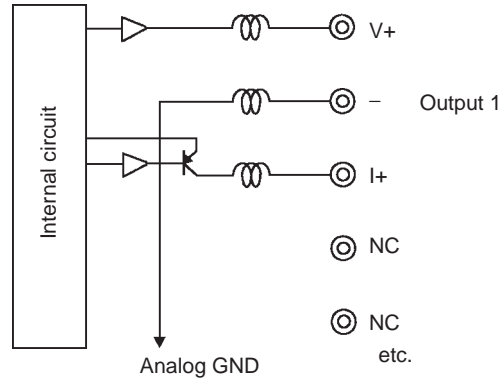

Pin	Analog I/O Unit		
	CPM2B-MAD63	CPM2B-MAD42	CPM2B-MAD21
1	Analog voltage output 0	Analog voltage output 0	Analog voltage output 0
2	Analog output COM	Analog output COM	Analog output COM
3	N.C.	N.C.	N.C.
4	Analog voltage output 1	Analog voltage output 1	N.C.
5	Analog output COM	Analog output COM	N.C.
6	N.C.	N.C.	N.C.
7	Analog voltage output 2	N.C.	N.C.
8	Analog output COM	N.C.	N.C.
9	Analog current output 0	Analog current output 0	Analog current output 0
10	N.C.	N.C.	N.C.
11	N.C.	N.C.	N.C.
12	Analog current output 1	Analog current output 1	N.C.
13	N.C.	N.C.	N.C.
14	N.C.	N.C.	N.C.
15	Analog current output 2	N.C.	N.C.

N.C.: Not used.

Analog Output Wiring

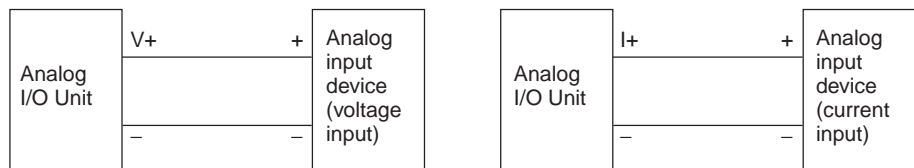

Note 1. When using shielded cables, do not connect the shield wire.

2. Lay AC power supply lines and power lines separately.
3. If noise interference from the power lines occurs, insert a noise filter in the power supply and input section.

Preparing Analog I/O Cables

Analog I/O Boards are provided with two special I/O connectors. Always use the provided connectors or equivalent products when wiring I/O.

Plug	XM2D1501	OMRON
Hood	XM2S1511	

Cable

Use shielded twisted-pair wires for the cables.

Wiring and Assembly

Use the following procedure to wire and assemble the connectors.

- 1,2,3...
1. Pass the signal lines through heat-shrinking tube before soldering them to each pin in the plug.

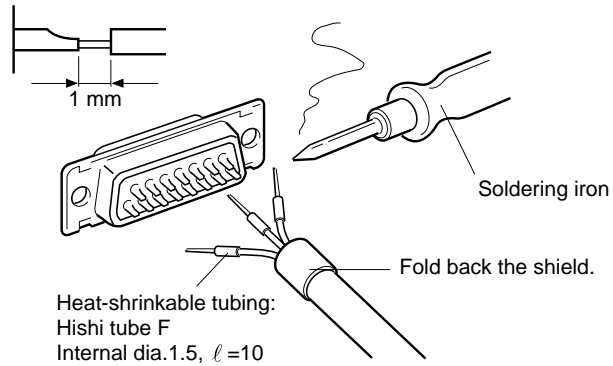

2. After soldering all the required pins, return the heat-shrinkable tube on the signal line to cover the solder joint, and shrink the tube using a hot air gun.

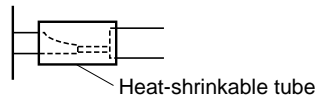

3. Assemble the plug and hood, as shown in the following diagram. Use aluminum foil tape to wrap the folded back shield wire at the connector on the Analog I/O Board, as shown in the diagram, and then fix to the hood.

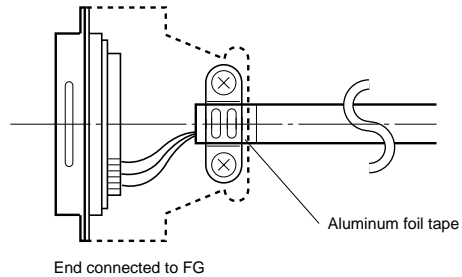

Note After wiring the connectors, always check that all wiring is correct before turning ON the power supply.

Refer to the following information if a disconnection occurs while using voltage input.

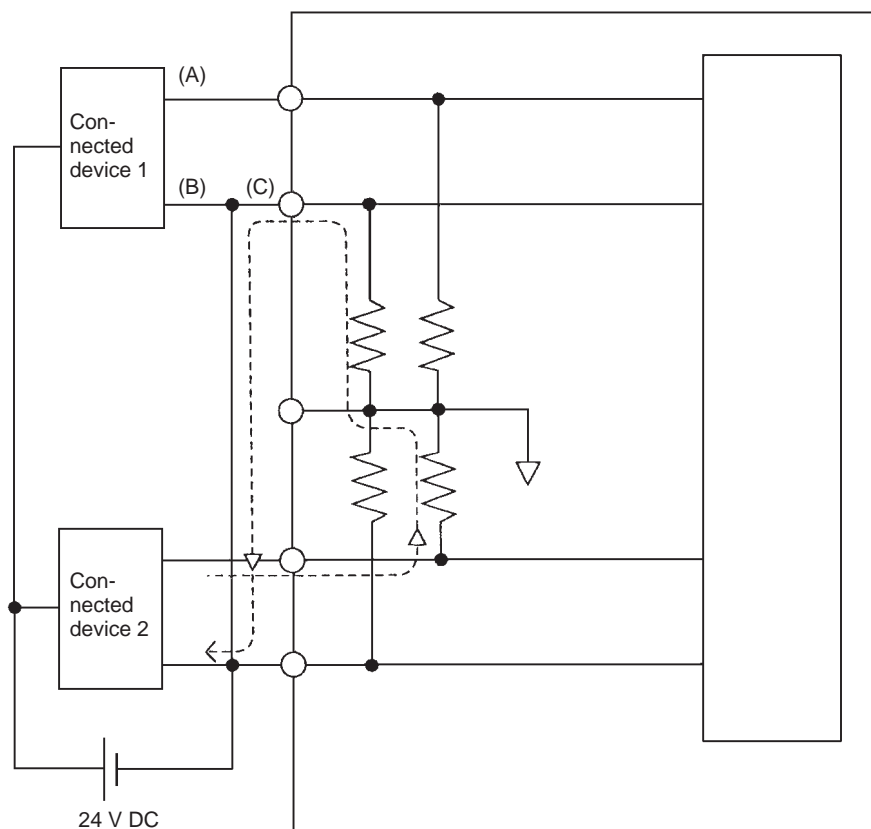

Example: If connected device 2 is outputting 5 V and the power supply is shared between two inputs, as shown in the above diagram, approximately 1.6 V (or a third) is generated at input 1.

If an input is disconnected while using a voltage input, the conditions described below will occur. Either use separate power supplies for the connected devices or use isolators to isolate each input.

If connected devices share a power supply and a line is disconnected at A or B, the unwanted path shown by the broken line in the above diagram will occur, and the output voltage of other connected devices will drop to around a third to half the voltage. If using the 1 to 5-V range when this type of voltage is generated, detection of a line disconnection will not be possible. Also, a line disconnection cannot be detected if the line is disconnected at C, because the negative side (–) is shared.

If a current input is used, the power supply can be shared by the connected devices without any problem.

Note When the external power supply is turned ON (and the range code has been set) or when the power is disconnected, a pulse analog output of 1 ms maximum may occur. If this situation causes a problem, use measures such as the following ones.

- Turn ON the power to the CPU Board, check the RUN status, and then turn ON the power to the load.
- Turn OFF the power to the load, and then turn OFF the power to the CPU Board.

6-4-4 Ladder Programming

Ladder programming is used to control the Analog I/O Board's range code settings and start conversion operations, as follows:

- 1,2,3...
1. Setting range codes
 2. Reading input (after A/D conversion) data
 3. Writing output (D/A conversion source) data

I/O Word Allocations

Analog I/O Boards are allocated I/O words following those words allocated to the CPU Board or a previously connected Expansion Board. The number of words allocated to the Analog I/O Board depends on the model of the Board used.

Model	Input words	Output words
CPM2B-MAD63	Words m+1 to m+6 (6 words)	Words n+1 to n+3 (3 words)
CPM2B-MAD42	Words m+1 to m+4 (4 words)	Words n+1 to n+2 (2 words)
CPM2B-MAD21	Words m+1 to m+2 (2 words)	Word n+1 (1 word)

m: The last input word allocated to the CPU Board or to the previous Board if one is already connected.

n: The last output word allocated to the CPU Board or to the previous Board if one is already connected.

Analog I/O Board Word Allocations

The following table shows the input word data.

Input words	CPM2B-MAD63	CPM2B-MAD42	CPM2B-MAD21
Word m+1	Input data 1 (4-digit hexadecimal)	Input data 1 (4-digit hexadecimal)	Input data 1 (4-digit hexadecimal)
Word m+2	Input data 2 (4-digit hexadecimal)	Input data 2 (4-digit hexadecimal)	Input data 2 (4-digit hexadecimal)
Word m+3	Input data 3 (4-digit hexadecimal)	Input data 3 (4-digit hexadecimal)	---
Word m+4	Input data 4 (4-digit hexadecimal)	Input data 4 (4-digit hexadecimal)	
Word m+5	Input data 5 (4-digit hexadecimal)	---	
Word m+6	Input data 6 (4-digit hexadecimal)		

Output Word Data (Range Code Settings)

Bit	15	14	13	12	11	10	09	08	07	06	05	04	03	02	01	00
Word n+1	1	0	0	0	0	0	0									
								Analog output 1			Analog input 2			Analog input 1		
Word n+2	1	0	0	0	0	0	0									
								Analog output 2			Analog input 4			Analog input 3		
Word n+3	1	0	0	0	0	0	0									
								Analog output 3			Analog input 6			Analog input 5		

The CPM2B-MAD21 uses word n+1 only. The CPM2B-MAD42 uses words n+1 and n+2 only.

Output Word Data (for Setting Analog Output Data)

The source data to be used for D/A conversion is set in the output data words as 4-digit hexadecimal.

Output words	CPM2B-MAD63	CPM2B-MAD42	CPM2B-MAD21
Word n+1	Output data 1 (4-digit hexadecimal)	Output data 1 (4-digit hexadecimal)	Output data 1 (4-digit hexadecimal)
Word n+2	Output data 2 (4-digit hexadecimal)	Output data 2 (4-digit hexadecimal)	---
Word n+3	Output data 3 (4-digit hexadecimal)	---	

The CPM2B-MAD21 uses word n+1 only. The CPM2B-MAD42 uses words n+1 and n+2 only.

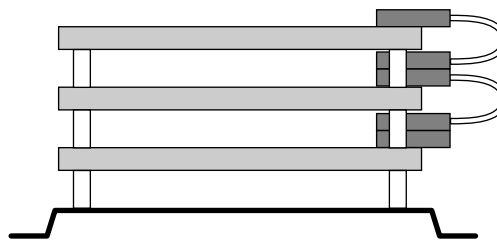
I/O Word Allocation Example

Board	Allocated I/O words	
	Input words	Output words
CPM2B-40C2DR-D CPU Board	IR 000 and IR 001	IR 010 and IR 011
CPM2B-40EDR Expansion I/O Board	IR 002 and IR 003	IR 012 and IR 013
CPM2B-MAD63 Analog I/O Board	IR 004 to IR 009	IR 014 to IR 016

Setting I/O Range Codes

Analog input or output conversion is started when one of the following range codes is set in the output words allocated to the Analog I/O Board. (Output words are also used to write output data.)

Range codes can be set separately for each input/output.

Range code	Analog input signal range	Analog output signal range
000	-10 to 10 V	-10 to 10 V
001	0 to 10 V	0 to 10 V
010	1 to 5 V/4 to 20 mA (See note.)	1 to 5 V
011	0 to 5 V/0 to 20 mA (See note.)	0 to 20 mA
100	---	4 to 20 mA

Note Analog input is switched between voltage and current input by setting DIP switch 1.

A/D conversion or D/A conversion processing will not be performed until the range code is correctly set. After being set, the range code cannot be changed during operation. The following tables show an example of range code settings and how the range codes are set in the output words.

Analog input/output	I/O range	Range code	Setting location	
			Word	Bits
Analog input 1	4 to 20 mA	010	Word n+1	00 to 02
Analog input 2	4 to 20 mA	010		03 to 05
Analog input 3	-10 to 10 V	000	Word n+2	00 to 02
Analog input 4	0 to 10 V	001		03 to 05
Analog input 5	0 to 5 V	010	Word n+3	00 to 02
Analog input 6	Not used.	---		03 to 05
Analog output 1	4 to 20 mA	010	Word n+1	06 to 08
Analog output 2	4 to 20 mA	010	Word n+2	06 to 08
Analog output 3	0 to 10 V	001	Word n+3	06 to 08



Bit	15	14	13	12	11	10	09	08	07	06	05	04	03	02	01	00
Word n+1 (#8092)	1	0	0	0	0	0	0	0	1	0	0	1	0	0	1	0
									Analog output 1			Analog input 2			Analog input 1	
Word n+2 (#8088)	1	0	0	0	0	0	0	0	1	0	0	0	1	0	0	0
									Analog output 2			Analog input 4			Analog input 3	
Word n+3 (#8042)	1	0	0	0	0	0	0	0	0	1	0	0	0	0	1	0
									Analog output 3			Analog input 6 (Not used.)			Analog input 5	

Ladder Programming Example for Writing Range Codes

Use SR 25315 (First Cycle Flag: Turns ON for 1 cycle at the start of operation) and the MOV(21) instruction to write the range code settings. Once the range code settings have been set, they are recorded by the Board when the power is ON.

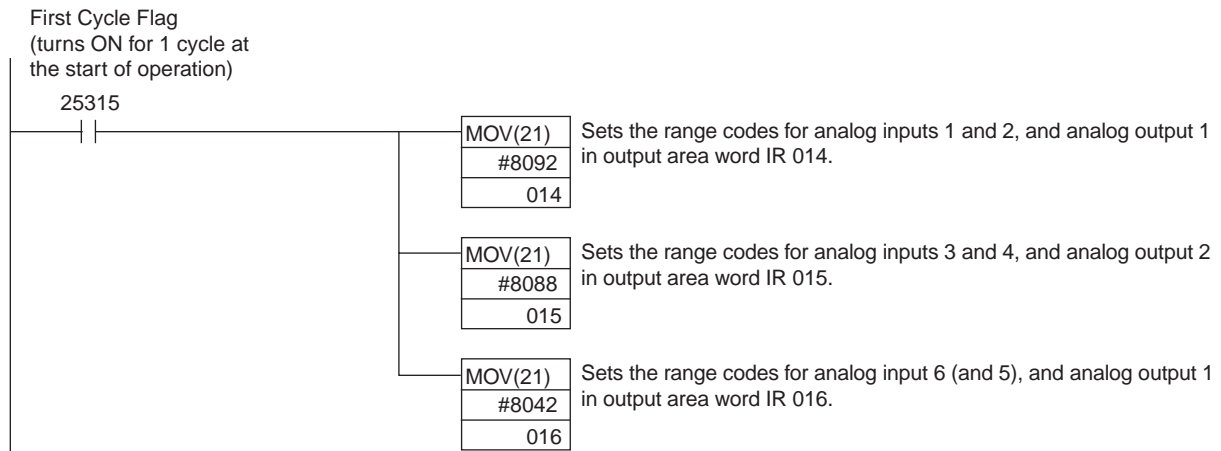

Reading Input Data (A/D Conversion Data)

Data that has been processed using A/D conversion is stored in 4-digit hexadecimal in the input words allocated to the Analog I/O Board.

A/D conversion data	A/D conversion data output words	CPM2B-MAD21	CPM2B-MAD42	CPM2B-MAD63
A/D conversion data 1	Word m+1	Used	Used	Used
A/D conversion data 2	Word m+2			
A/D conversion data 3	Word m+3	Not used	Not used	
A/D conversion data 4	Word m+4			
A/D conversion data 5	Word m+5			
A/D conversion data 6	Word m+6			

Ladder Programming Example for Reading Input Data

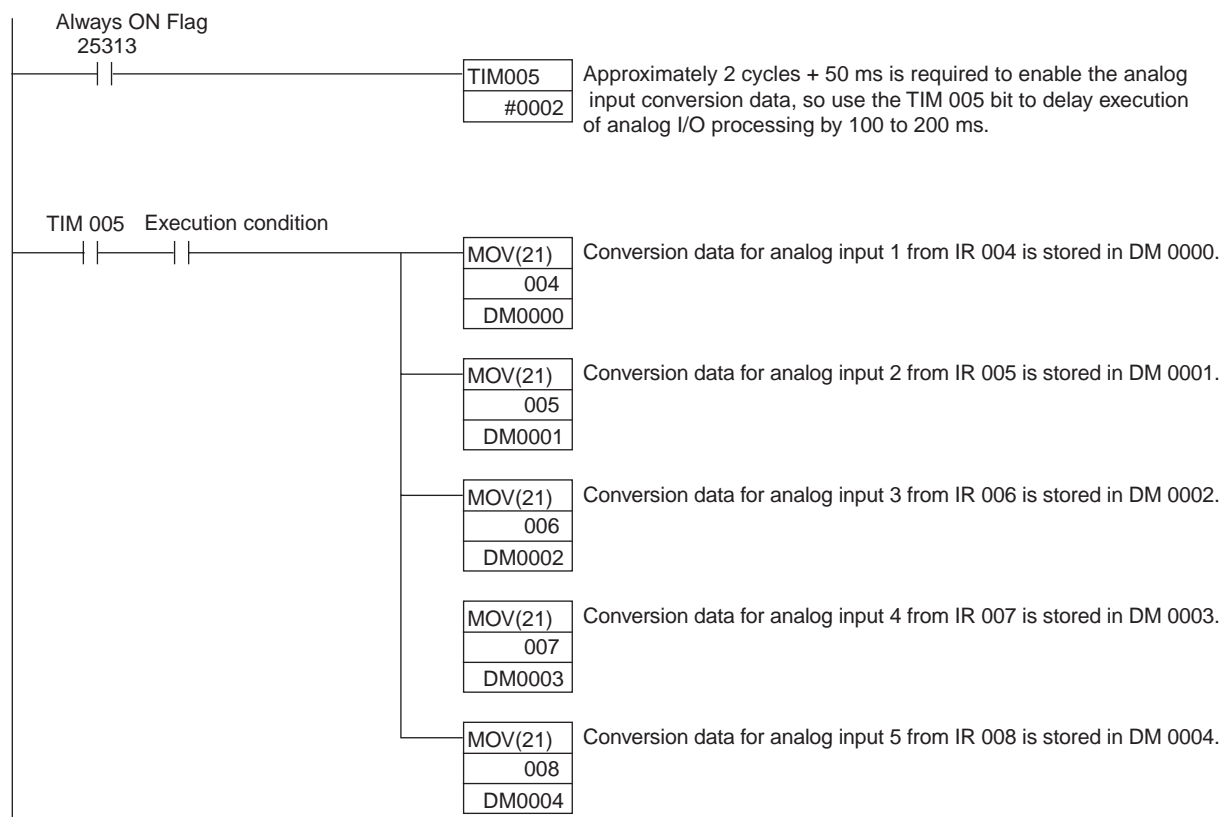

Input Disconnection Detection

When using the input range 1 to 5 V or 4 to 20 mA and the input voltage/current drops below the specified value, a circuit disconnection is detected internally and a conversion value of 8,000 is stored in the input words. When the voltage/current returns to a level within the specified range, the disconnection detected status is cleared, and normal conversion is resumed.

Disconnection Detection Operation

Input range	Operating range	Operating time	Recovery	
1 to 5 V	0.8 V max.	Same as A/D conversion time	0.8 V min.	After the voltage/current returns to the specified value or higher, and A/D conversion is performed, normal conversion values are output.
4 to 20 mA	3.2 mA max.		3.2 mA min.	

Ladder Programming Example Using Disconnection Detection

The following example shows ladder programming for detecting a disconnection of inputs 1 and 2 (4 to 20 mA).

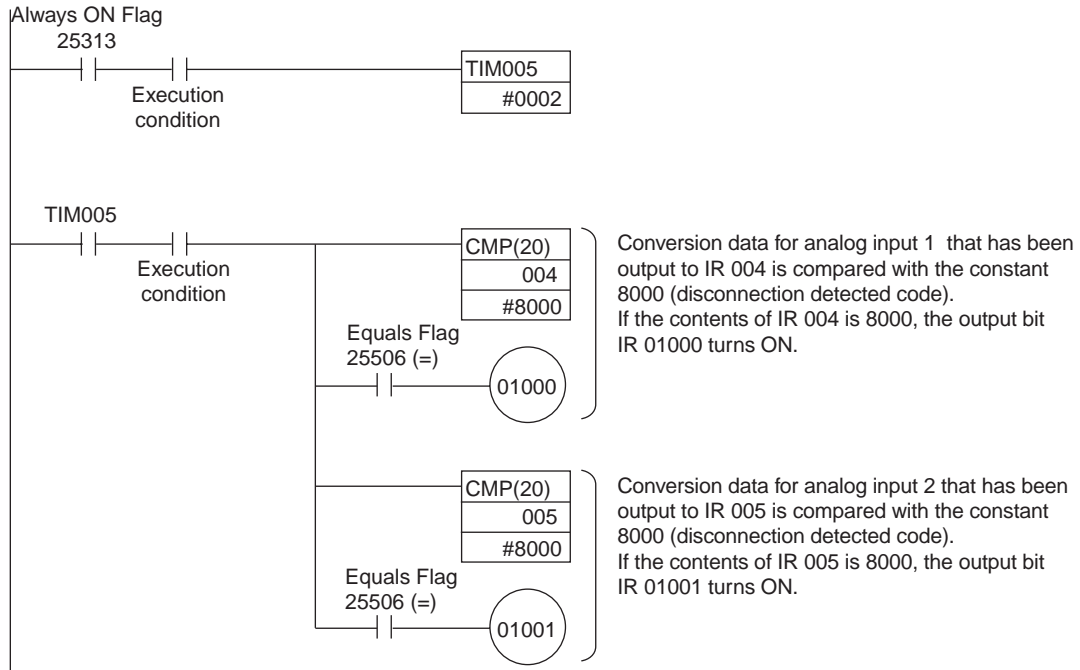

Setting Output Data (D/A Conversion Source Data)

The output data is set by writing the output data (4-bit hexadecimal) to the output words allocated to the Analog I/O Board. After using the output words for writing the range codes, these words are also used to write output data.

D/A conversion data	CPM2B-MAD63	CPM2B-MAD42	CPM2B-MAD21
D/A conversion data 0	Word n+1	Word n+1	Word n+1
D/A conversion data 1	Word n+2	Word n+2	---
D/A conversion data 2	Word n+3	---	

When the output data is outside the specified conversion range, the minimum value is output if the value is below the minimum value and the maximum value is output if the value exceeds the maximum value.

Ladder Programming Example for Setting Output Data

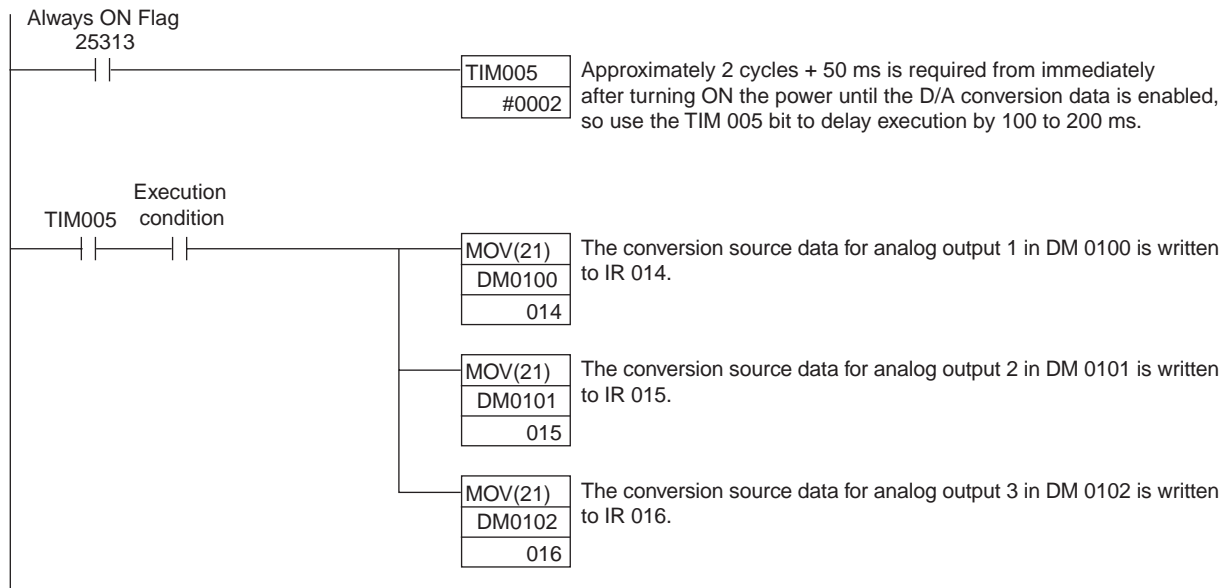

6-5 Troubleshooting Unit Errors

If an error occurs in an Analog I/O Board, the corresponding flag in the Expansion Board Error Flags AR 0200 to AR 0207 will turn ON. These flags are allocated one at a time starting from AR 0200, and are allocated to the Boards in the order they were connected.

- Expansion I/O Boards are all allocated one flag per Board.
- Analog I/O Boards are allocated flags according to the model, as follows:
 - CPM2B-MAD21: 1 flag
 - CPM2B-MAD42: 2 flags
 - CPM2B-MAD63: 3 flags

Therefore, if the CPM2B-MAD42 and CPM2B-MAD63 are connected, there will be more than one Error Flags for the Board, so take an OR of these flags to detect an error.

Ladder Programming Example

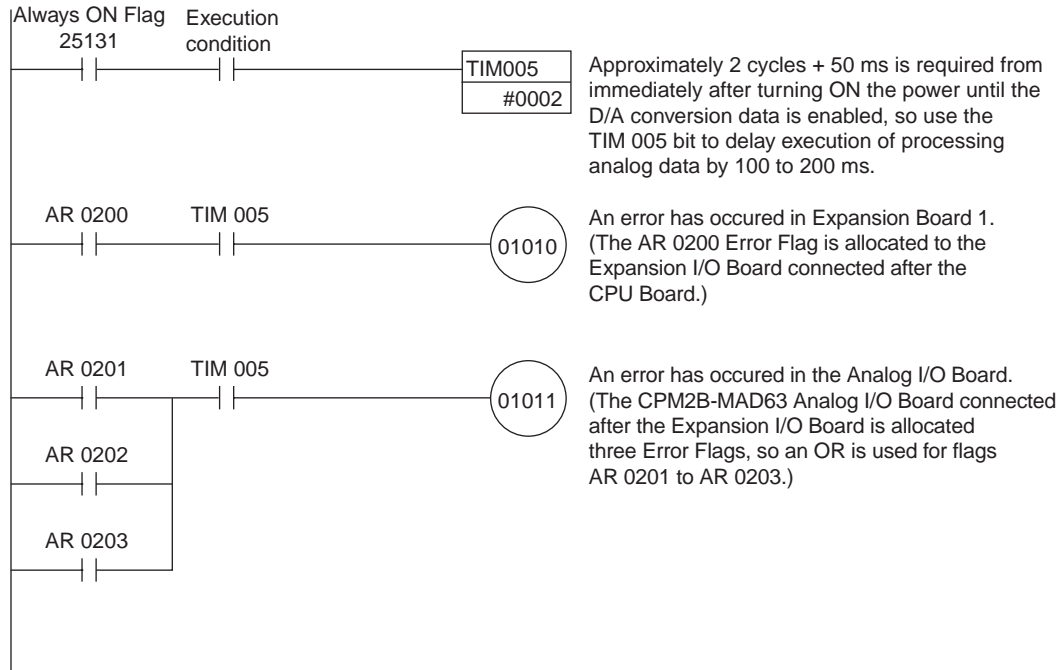

Approximately 2 cycles + 50 ms is required from immediately after turning ON the power until the D/A conversion data is enabled, so use the TIM 005 bit to delay execution of processing analog data by 100 to 200 ms.

An error has occurred in Expansion Board 1. (The AR 0200 Error Flag is allocated to the Expansion I/O Board connected after the CPU Board.)

An error has occurred in the Analog I/O Board. (The CPM2B-MAD63 Analog I/O Board connected after the Expansion I/O Board is allocated three Error Flags, so an OR is used for flags AR 0201 to AR 0203.)

SECTION 7

Using Programming Devices

This section outlines the operations possible with the Programming Consoles.

7-1	Using a Programming Console	120
7-1-1	Compatible Programming Consoles	120
7-1-2	Changing the CPM2B's Mode with the Mode Switch	122
7-1-3	Connecting the Programming Console	124
7-1-4	Preparation for Operation	125
7-1-5	Entering the Password	126
7-2	Programming Console Operations.	127
7-2-1	Overview	127
7-2-2	Clearing Memory	128
7-2-3	Clearing Memory Completely.	129
7-2-4	Reading UM Allocation Information	129
7-2-5	Reading/Clearing Error Messages.	130
7-2-6	Buzzer Operation.	131
7-2-7	Assigning Expansion Instruction Function Codes	131
7-2-8	Setting and Reading a Program Memory Address and Monitoring I/O Bit Status	132
7-2-9	Entering or Editing Programs	133
7-2-10	Instruction Search	136
7-2-11	Bit Operand Search	137
7-2-12	Inserting and Deleting Instructions	138
7-2-13	Checking the Program.	139
7-2-14	Bit, Digit, Word Monitor.	140
7-2-15	Differentiation Monitor	142
7-2-16	Binary Monitor	143
7-2-17	Three-Word Monitor	143
7-2-18	Signed Decimal Monitor	144
7-2-19	Unsigned Decimal Monitor	145
7-2-20	Three-Word Data Modification	145
7-2-21	Changing Timer, Counter SV	146
7-2-22	Hexadecimal, BCD Data Modification	147
7-2-23	Binary Data Modification	148
7-2-24	Signed Decimal Data Modification	149
7-2-25	Unsigned Decimal Data Modification.	150
7-2-26	Force Set, Reset.	150
7-2-27	Clear Force Set/Reset	151
7-2-28	Hex-ASCII Display Change	152
7-2-29	Displaying the Cycle Time	152
7-2-30	Reading and Setting the Clock	153
7-3	Programming Example	153
7-3-1	Preparatory Operations	153
7-3-2	Example Program	155
7-3-3	Programming Procedures	156
7-3-4	Checking the Program.	159
7-3-5	Test Run in MONITOR Mode.	160

7-1 Using a Programming Console

This section provides information on connecting and using a Programming Console.

7-1-1 Compatible Programming Consoles

There are 3 Programming Consoles that can be used with the CPM2B: The CQM1H-PRO01-E, CQM1-PRO01-E and the C200H-PRO27-E. The key functions for these Programming Consoles are identical.

Press and hold the Shift Key to input a letter shown in the upper-left corner of the key or the upper function of a key that has two functions. For example, the CQM1H-PRO01-E, CQM1-PRO01-E's AR/HR Key can specify either the AR or HR Area; press and release the Shift Key and then press the AR/HR Key to specify the AR Area.

CQM1H-PRO01-E

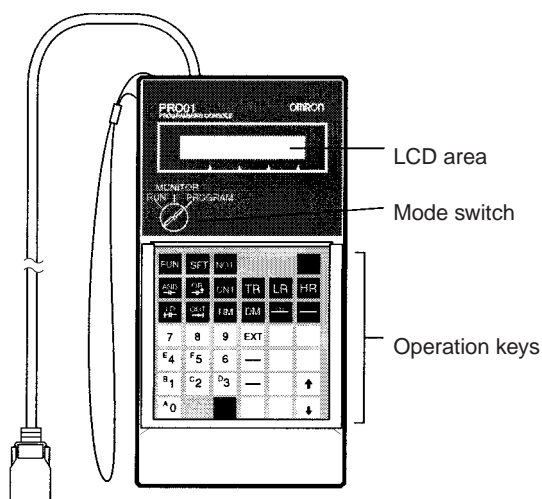

CQM1-PRO01-E

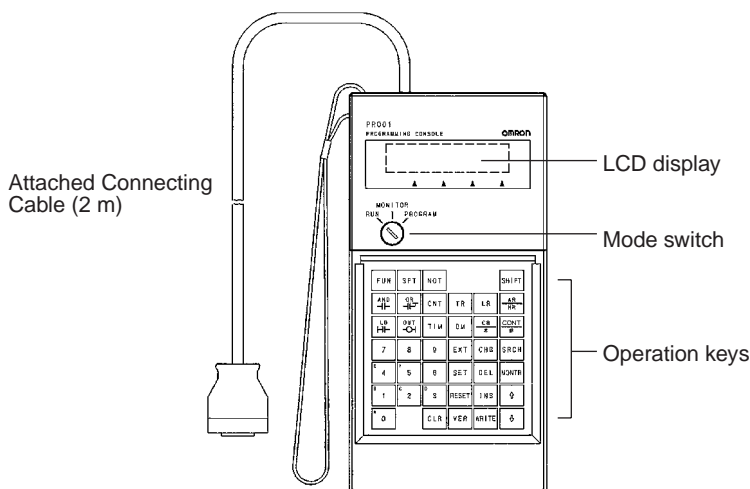

C200HPRO27E

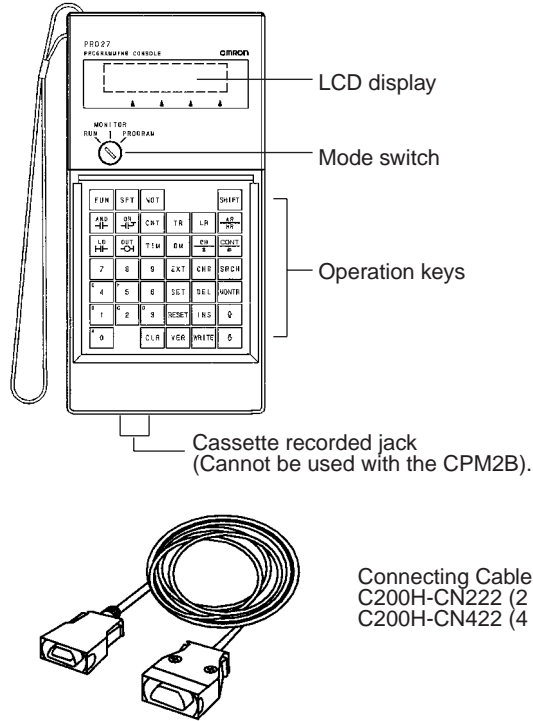

Different Keys

The following keys are labeled differently on the CQM1-PRO01-E and the C200H-PRO27-E, but the operation of the keys in each pair is identical.

CQM1-PRO01-E Keys	C200H-PRO27-E Keys
AR HR	HR
SET	PLAY SET
RESET	REC RESET

Note To specify the AR Area, use SHIFT and HR Keys for the C200H-PRO27-E and use SHIFT and AR/HR Keys for the CQM1-PRO01-E.

A shift symbol will be displayed in the upper-right corner of the screen when the Shift Key is pressed. The shift input can be cleared by pressing the Shift Key again.



Mode Switch

The mode switch controls the CPM2B's operating mode. The key can be removed when the switch is set to RUN or MONITOR but it cannot be removed when the switch is set to PROGRAM.

Contrast Control

The display contrast can be adjusted with the control on the right side of the Programming Console.

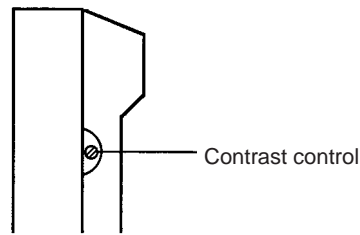
**Buzzer Volume**

The C200H-PRO27-E's buzzer volume can be adjusted with the lever on the right side of the Programming Console. The CQM1-PRO01-E's buzzer volume cannot be adjusted.

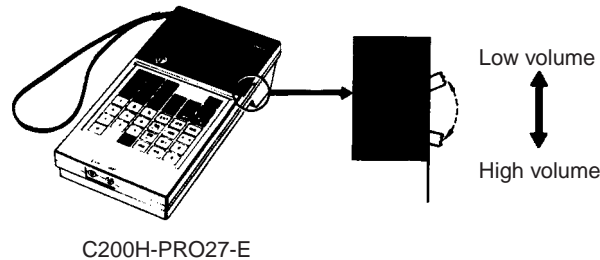

Note The buzzer volume can be turned on and off with a key operation. See 7-2-6 *Buzzer Operation* for details.

7-1-2 Changing the CPM2B's Mode with the Mode Switch

Once the Programming Console has been connected, its mode switch can be used to change the CPM2B's operating mode. The mode display (<PROGRAM>, <MONITOR>, or <RUN>) will appear on the Programming Console screen.

- No key operations can be performed while the mode display is displayed on the Programming Console screen. Press CLR to clear the display so that key operations can be performed.
- If the SHIFT Key is pressed while the mode switch is turned, the original display will remain on the Programming Console's screen and the mode display won't appear.

- The CPM2B will enter RUN mode automatically if a Programming Console isn't connected when the CPM2B is turned on.

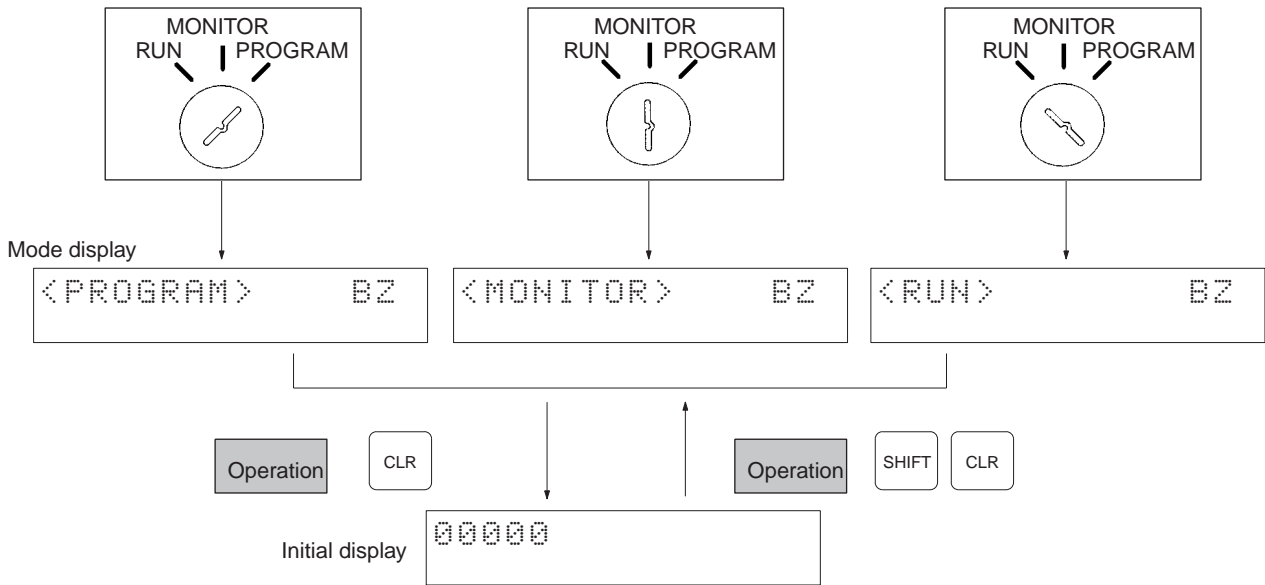

Operating Modes

PROGRAM Mode

The CPM2B program isn't executed in PROGRAM mode. Use PROGRAM mode to create and edit the program, clear memory, or check the program for errors, or check output wiring.

MONITOR Mode

The CPM2B program is executed in MONITOR mode and I/O is processed just as it is in RUN mode. Use MONITOR mode to test system operations, such as monitoring CPM2B operating status, force-setting and resetting I/O bits, changing the SV/PV of timers and counters, changing word data, and online editing.

RUN Mode

This is the CPM2B's normal operating mode. The CPM2B's operating status can be monitored from a Programming Device, but bits can't be force-set/force-reset and the SV/PV of timers and counters can't be changed.

⚠ Caution Check the system thoroughly before changing the operating mode of the PLC to prevent any accidents that might occur when the program is first started.

⚠ Caution Never change the mode while pressing any of the keys.

Startup Operating Mode

The operating mode of the CPM2B when the power is turned ON depends upon the PLC Setup setting in DM 6600 and the Programming Console's mode switch setting if the Programming Console is connected.

PLC Setup setting (DM 6600)	Programming Console connected	Programming Console not connected
00xx	The startup mode determined by the mode switch setting.	RUN mode if no Programming Device is connected. PROGRAM mode if another Programming Device is connected.
01xx	The startup mode is the same as the operating mode before power was interrupted.	
0200	PROGRAM mode	
0201	MONITOR mode	
0202	RUN mode	

Note The default setting is 00xx. With this default setting, the PLC will automatically enter RUN mode if a Programming Console is not connected and SW201 is ON. Be sure that it is safe for the PLC to operate before turning it ON under these conditions.

7-1-3 Connecting the Programming Console

Connect the Programming Console's connecting cable to the CPM2B's peripheral port, as shown below.

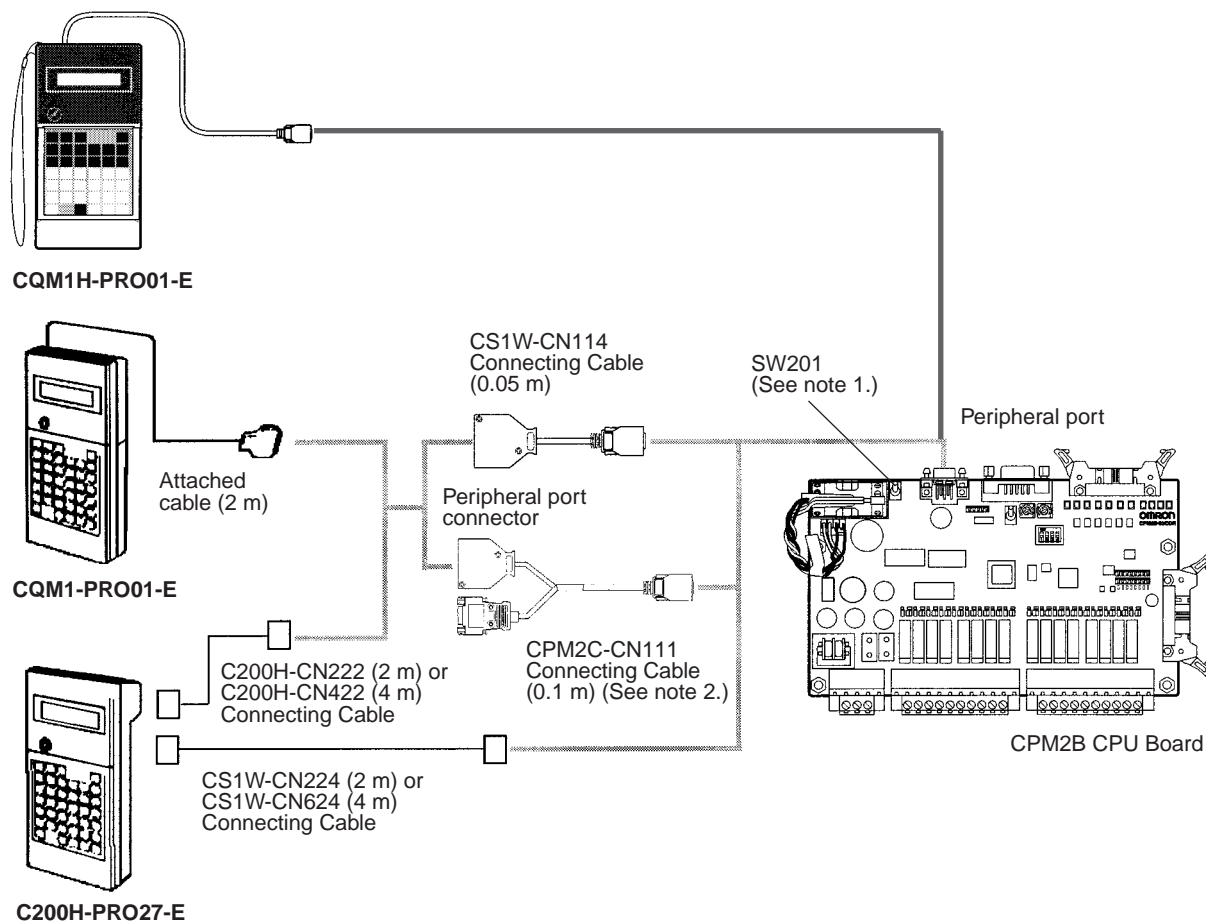

Note 1. Always turn OFF SW 201 before connecting the Programming Console.

- Only the peripheral port connector can be used when a CPM2C-CN111 Connecting Cable is connected.

Panel Installation

The C200H-PRO27-E Programming Console can be installed in a control panel as shown in the following diagram. (The C200H-ATT01 Mounting Bracket is sold separately.)

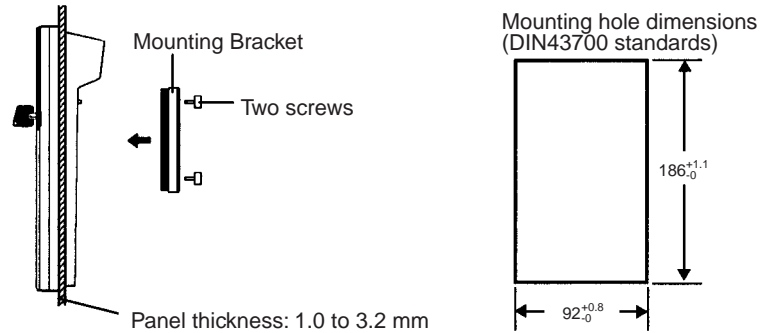

Allow at least 80 mm for the cable connector above the Programming Console.

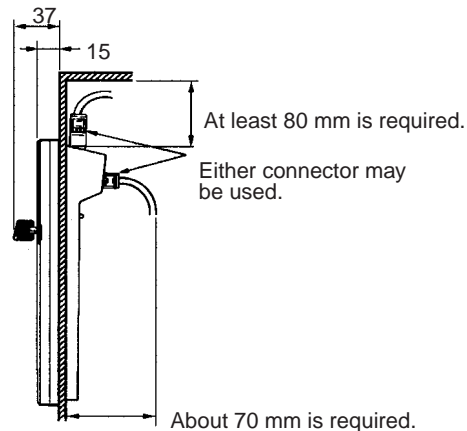

7-1-4 Preparation for Operation

This section describes the procedures required to begin Programming Console operation when using the Programming Console for the first time.

⚠ Caution Always confirm that the Programming Console is in PROGRAM mode when turning ON the PLC with a Programming Console connected unless another mode is desired for a specific purpose. If the Programming Console is in RUN mode when PLC power is turned ON, any program in Program Memory will be executed, possibly causing a PLC-controlled system to begin operation.

The following sequence of operations must be performed before beginning initial program input.

- 1,2,3...**
- Be sure that the PLC is OFF.
 - Connect the Programming Console to the CPU Board's peripheral port. See 7-1-3 *Connecting the Programming Console* for details. (The CPU Board's Communications Switch setting has no effect on communications with the Programming Console.)
 - Set the mode switch to PROGRAM mode.
 - Turn ON the PLC.
 - Enter the password. See 7-1-5 *Entering the Password* for details.
 - Clear (All Clear) the PLC's memory. See 7-2-2 *Clearing Memory* for details.

7. Read and clear all errors and messages. See 7-2-5 Reading/Clearing Error Messages for details.
8. Start programming.

7-1-5 Entering the Password

To gain access to the PLC's programming functions, you must first enter the password. The password prevents unauthorized access to the program.

The PLC prompts you for a password when PLC power is turned on or, if PLC power is already on, after the Programming Console has been connected to the PLC. To gain access to the system when the "Password!" message appears, press CLR and then MONTR. Then press CLR to clear the display.

If the Programming Console is connected to the PLC when PLC power is already on, the first display below will indicate the mode the PLC was in before the Programming Console was connected. **Ensure that the PLC is in PROGRAM mode before you enter the password.** When the password is entered, the PLC will shift to the mode set on the mode switch, causing PLC operation to begin if the mode is set to RUN or MONITOR. The mode can be changed to RUN or MONITOR with the mode switch after entering the password.

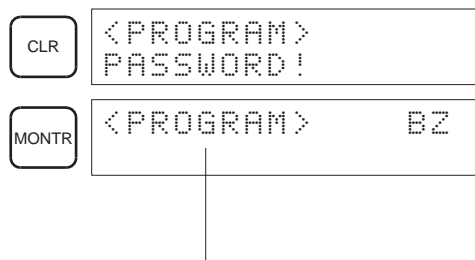

Indicates the mode set by the mode selector switch.

Automatic Mode Change

When the PLC is in RUN mode with a Programming Console connected to the peripheral port of the CPU Board, if a PT is connected to the Board's RS-232C port using Host Link mode, the following message will be displayed at the Programming Console indicating that a password is required to continue operation (using the Programming Console).

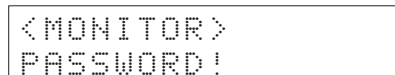

This is because, in order to write data to the CPU Unit, the PT changed the operation mode from RUN mode to MONITOR mode. To continue operation using the Programming Console, it is necessary to input the password again.

Inputting the Password



- The mode will not be changed if the PT is connected via an NT Link.

- When a Programming Device installed on a computer is connected to the peripheral port, the display (at the computer) for the CPU Unit's operation mode will simply change from "RUN" to "MONITOR."

7-2 Programming Console Operations

7-2-1 Overview

The following table lists the programming and monitoring operations that can be performed from a Programming Console. Refer to the rest of this section for details on operational procedures.

Name	Function	Page
Clearing memory	Clears all or part of the Program Memory and any data areas that are not read-only, as well as the contents of the Programming Console's memory.	128
Clearing memory completely	Clears all of memory, including the user program, PC Setup, all data areas, and the I/O comment area (set with version 2.0 or later of CX-Programmer).	129
Reading UM allocation information	Reads the I/O comment area and user program area capacities when an I/O comment area has been set with version 2.0 or later of CX-Programmer.	129
Reading/clearing error messages	Displays and clears error messages and displays MESSAGE instruction messages.	130
Buzzer operation	Turns on and off the buzzer that sounds when Programming Console keys are pressed.	131
Assigning expansion instruction function codes	Reads or changes the function codes assigned to expansion instructions	131
Setting a program memory address	Sets the specified program memory address when reading, writing, inserting and deleting programs.	132
Reading a program memory address	Reads the contents of the Program Memory. Displays the status of the currently displayed bit in PROGRAM and MONITOR modes.	132
Instruction search	Finds occurrences of the specified instruction in the program.	136
Bit operand search	Finds occurrences of the specified operand bit in the program.	137
Inserting and deleting instructions	Inserts or deletes instructions from the program.	138
Entering or editing programs	Overwrites the contents of the current Program Memory to either input a program for the first time or to change a program that already exists.	133
Checking the program	Checks for programming errors and displays the program address and error when errors are found.	139
Bit, digit, word monitor	Monitors the status of up to 16 bits and words, although only 3 can be shown on the display at one time.	140
Multiple address monitor	Monitors the status of up to 6 bits and words simultaneously.	141
Differentiation monitor	Monitors the up or down differentiation status of a particular bit.	142
Binary monitor	Monitors the ON/OFF status of any word's 16 bits.	143
Three-word monitor	Monitors the status of three consecutive words.	143
Signed decimal monitor	Converts the contents of the specified word from signed hexadecimal (two's complement format) to signed decimal for display.	144
Unsigned decimal monitor	Converts hexadecimal data in a word to unsigned decimal for display.	145
3-word data modification	Changes the contents of one or more of the 3 consecutive words displayed in the 3-Word Monitor operation.	145
Changing timer, counter SV 1	Changes the SV of a timer or counter.	146
Changing timer, counter SV 2	Makes fine adjustment changes to the SV of the timer or counter.	147
Hexadecimal, BCD data modification	Changes the BCD or hexadecimal value of a word being monitored.	147
Binary data modification	Changes the status of a word's bits when the word is being monitored.	148
Signed decimal data modification	Changes the decimal value of a word being monitored as signed decimal data, within a range of -32,768 to 32,767. The contents of the specified word are converted automatically to signed hexadecimal (two's complement format.)	149

Name	Function	Page
Unsigned decimal data modification	Changes the decimal value of a word being monitored as unsigned decimal data, within a range of 0 to 65,535. A change into hexadecimal data is made automatically.	150
Force set/reset	Forces bits ON (force set) or OFF (force reset.)	150
Clear force set/reset	Restores the status of all bits which have been force set or reset.	151
Hex-ASCII display change	Converts word data displays back and forth between 4-digit hexadecimal data and ASCII.	152
Displaying the cycle time	Displays the current average cycle time (scan time.)	152
Reading and setting the clock	Reads or sets the internal clock.	153

7-2-2 Clearing Memory

This operation is used to clear all or part of the Program Memory and data areas, as well as the contents of the Programming Console's memory. This operation is possible in PROGRAM mode only.

RUN	MONITOR	PROGRAM
No	No	OK

Before beginning to program for the first time or when installing a new program, clear all areas.

All Clear

The following procedure is used to clear memory completely, including the program, all data areas, counter PVs, Data Memory, and the PLC Setup (DM 6600 to DM 6655).

- 1,2,3... 1. Bring up the initial display by pressing the CLR Key repeatedly.
 2. Press the SET, NOT, and then the RESET Key to begin the operation.

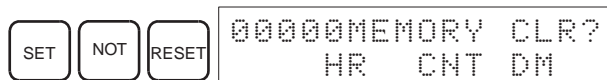

3. Press the MONTR Key to clear memory completely.

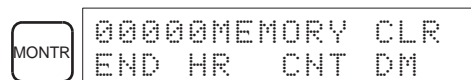

Caution The PLC Setup (DM 6600 through DM 6655) will be cleared when this operation is performed.

Partial Clear

It is possible to retain the data in specified areas or part of the Program Memory. To retain the data in the HR, TC, or DM Areas, press the appropriate key after pressing SET, NOT, and RESET. Any data area that still appears on the display will be cleared when the MONTR Key is pressed.

The HR Key is used to specify both the AR and HR Areas, the CNT Key is used to specify the entire timer/counter area, and the DM Key is used to specify the DM Area.

It is also possible to retain a portion of the Program Memory from the first memory address to a specified address. After designating the data areas to be retained, specify the first Program Memory address to be cleared. For example, input 030 to leave addresses 000 to 029 untouched, but to clear addresses from 030 to the end of Program Memory.

As an example, follow the procedure below to retain the timer/counter area and Program Memory addresses 000 through 122:

- 1,2,3... 1. Press the CLR Key to bring up the initial display.

2. Press the SET, NOT, and then the RESET Key to begin the operation.
3. Press the CNT Key to remove the timer/counter area from the data areas shown on the display. (Counter PVs will not be cleared.)

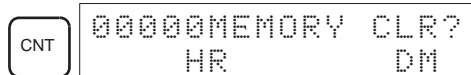

4. Press 123 to specify 123 as the starting program address.

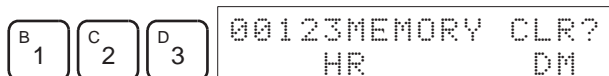

5. Press the MONTR Key to clear the specified regions of memory.

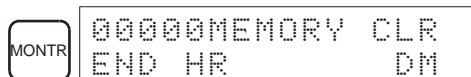

7-2-3 Clearing Memory Completely

This operation is used to clear all of memory, including the user program, PC Setup, all data areas, and the I/O comment area (set with version 2.0 or later of CX-Programmer).

RUN	MONITOR	PROGRAM
No	No	OK

The I/O comment function was supported for the CPM2B starting from version 2.0 of CX-Programmer. This operation must be used to delete the I/O comment area. The contents of the I/O comment area will be deleted and the area size will be returned to the default value of 2.0 Kwords.

Key Sequence

Follow the procedure below to clear memory completely.

1,2,3...

1. Press the CLEAR, SET, NOT, RESET, and then the EXT Key to begin the operation.

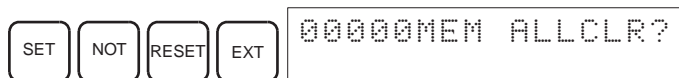

2. Press the MONTR Key to clear memory completely.

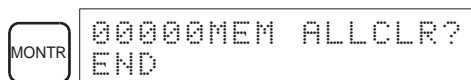

This operation must be used when it is necessary to clear the program and I/O comment area. There are no other Programming Console operation that can be used to clear the I/O comment area.

7-2-4 Reading UM Allocation Information

This operation is used to read the I/O comment area and ladder program area capacities when an I/O comment area has been set with version 2.0 or later of CX-Programmer.

RUN	MONITOR	PROGRAM
OK	OK	OK

Refer to the *CX-Programmer User Manual* (version 2.0 or later) for information on changing the size of the I/O comment area.

Key Sequence

Press the CLR, FUN and then the VER Key to display the I/O comment area and ladder program area capacities.

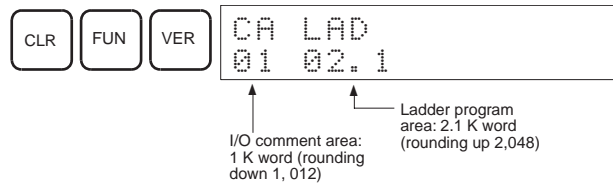

7-2-5 Reading/Clearing Error Messages

This operation is used to display and clear error messages. It is possible to display and clear non-fatal errors and MESSAGE instruction messages in any mode, but fatal errors can be cleared in PROGRAM mode only.

RUN	MONITOR	PROGRAM
OK	OK	OK

Before inputting a new program, any error messages recorded in memory should be cleared. It is assumed here that the causes of any of the errors for which error messages appear have already been taken care of. If the buzzer sounds when an attempt is made to clear an error message, eliminate the cause of the error, and then clear the error message. (Refer to SECTION 8 Test Runs and Error Processing for troubleshooting information.)

Key Sequence

Follow the procedure below to display and clear messages.

1,2,3...

1. Press the CLR Key to bring up the initial display.
2. Press the FUN and then the MONTR Key to begin the operation. If there are no messages, the following display will appear:

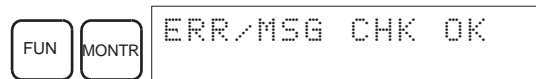

If there are messages, the most serious message will be displayed when the MONTR Key is pressed. Pressing MONTR again will clear the present message and display the next most serious error message. Continue pressing MONTR until all messages have been cleared. These are some examples of error messages:

A memory error:

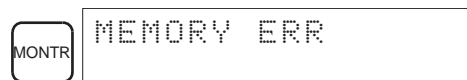

A system error:

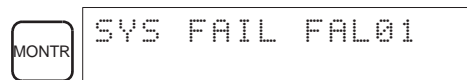

A message (displayed with MSG(46)):

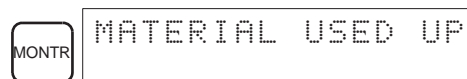

All messages cleared:

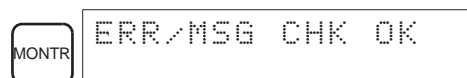

7-2-6 Buzzer Operation

This operation is used to turn on and off the buzzer that sounds when Programming Console keys are pressed. This buzzer will also sound whenever an error occurs during PLC operation. Buzzer operation for errors is not affected by this setting.

This operation is possible in any mode.

RUN	MONITOR	PROGRAM
OK	OK	OK

Key Sequence

Follow the procedure below to turn the key-input buzzer on and off.

- 1,2,3... 1. Press the CLR, SHIFT, and then the CLR Key to bring up the mode display. In this case the PLC is in PROGRAM mode and the buzzer is ON.

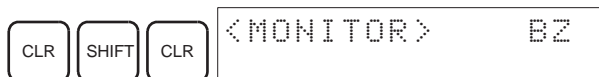

2. Press the SHIFT and then the 1 Key to turn off the buzzer.

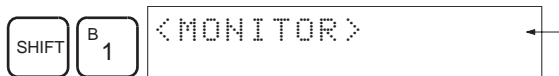

The buzzer will not sound when "BZ" is not displayed.

3. Press the SHIFT and then the 1 Key again to turn the buzzer back ON.

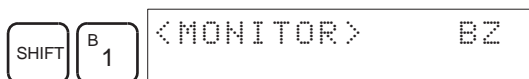

7-2-7 Assigning Expansion Instruction Function Codes

This operation is used to display or change the expansion instructions assigned to expansion instruction function codes. The assignments can be displayed in any mode, but can be changed in PROGRAM mode only.

Operation	RUN	MONITOR	PROGRAM
Read assignment	OK	OK	OK
Change assignment	No	No	OK

Assign expansion instruction function codes before inputting the program. The CPM2B will not operate properly if expansion instructions aren't assigned correctly. An expansion instruction can be assigned to one function code only.

The PLC Setup must be set for user-defined expansion instruction assignments. Set bits 8 to 11 of DM 6602 to 1 and turn the PLC's power OFF and then ON again to enable the new setting.

There are tables in SECTION 5 *Instruction Set* showing the default function code assignments in the CPM2B.

- 1,2,3... 1. Press the CLR Key to bring up the initial display.
 2. Press the EXT Key to display the assignment for the first function code (17).

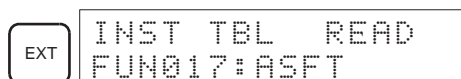

3. Press the Up and Down Arrow Keys to scroll through the expansion instruction function codes.



4. Press the CHG Key to assign a different expansion instruction to the selected function code.

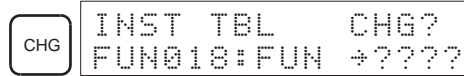

5. Press the Up and Down Arrow Keys to scroll through the expansion instructions that can be assigned to the selected function code.

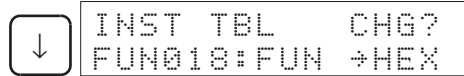

6. Press the WRITE Key to assign the displayed instruction to the function code.

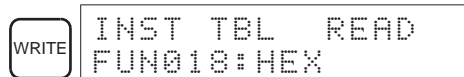

7-2-8 Setting and Reading a Program Memory Address and Monitoring I/O Bit Status

This operation is used to display the specified program memory address and is possible in any mode. In the RUN or MONITOR mode, the I/O bit status of bits in the program will be displayed.

RUN	MONITOR	PROGRAM
OK	OK	OK

When inputting a program for the first time, it is generally written to Program Memory starting from address 000. Because this address appears when the display is cleared, it is not necessary to specify it.

When inputting a program starting from other than 000 or to read or modify a program that already exists in memory, the desired address must be designated.

1,2,3...

1. Press the CLR Key to bring up the initial display.
2. Input the desired address. It is not necessary to input leading zeroes.

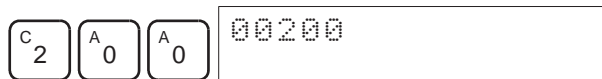

3. Press the Down Arrow Key.

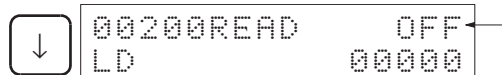

In the RUN or MONITOR mode, ON/OFF status of the bit will be displayed.

Pressing the MONTR Key will change to the I/O monitor display. Bits can be force-set or force-reset from the I/O monitor display. Press the CLR Key to return to I/O bit status monitoring of the initial address.

Note The ON/OFF status of any displayed bit will be shown if the PLC is in RUN or MONITOR mode.

4. Press the Up and Down Arrow Keys to scroll through the program.

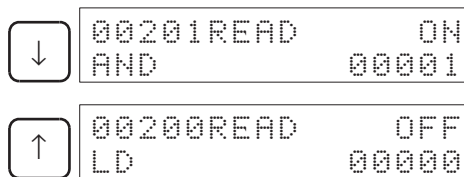

7-2-9 Entering or Editing Programs

This operation is used enter or edit programs. It is possible in PROGRAM mode only.

RUN	MONITOR	PROGRAM
No	No	OK

The same procedure is used to either input a program for the first time or to change a program that already exists. In either case, the current contents of Program Memory is overwritten.

The program shown in the following diagram will be entered to demonstrate this operation.

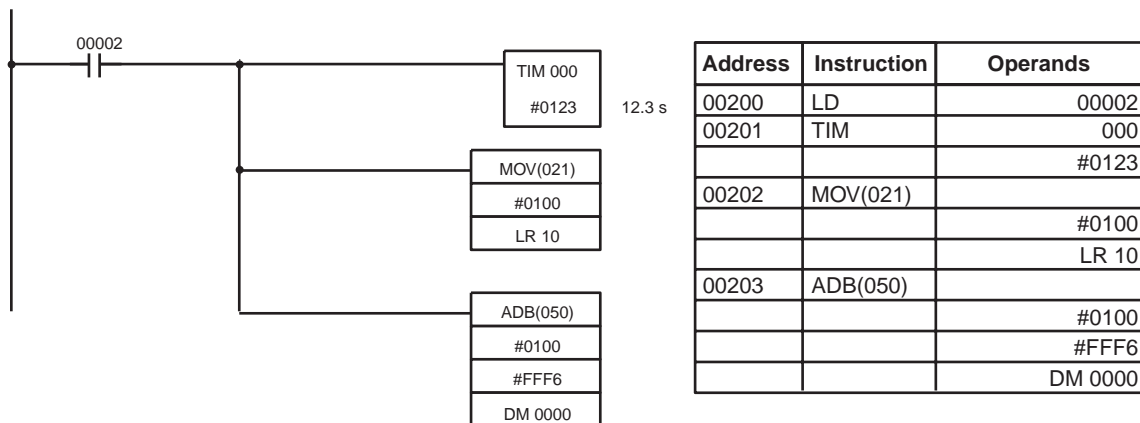

- 1,2,3...**
1. Press the CLR Key to bring up the initial display.
 2. Specify the address where the program will begin.
 3. Input the address where the program will begin and press the Down Arrow Key. It is not necessary to input leading zeroes.

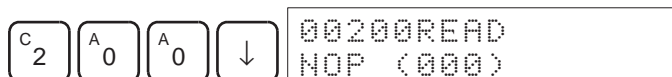

4. Input the first instruction and operand.

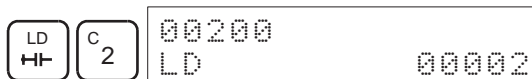

5. Press the WRITE Key to write the instruction to Program Memory. The next program address will be displayed.

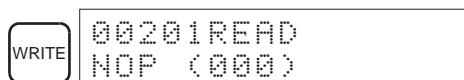

If a mistake was made inputting the instruction, press the Up Arrow Key to return to the previous program address and input the instruction again. The mistaken instruction will be overwritten

To specify the Completion Flag for a timer or counter, press the LD, AND, OR, or NOT Key followed by the TIM or CNT Key, and then input the timer/counter number last.

- Input the second instruction and operand. (In this case it isn't necessary to enter the timer number, because it's 000.) Press the WRITE Key to write the instruction to Program Memory.



- Input the second operand (123 to specify 12.3 seconds) and press the WRITE Key. The next program address will be displayed.



If a mistake was made inputting the operand, press the Up Arrow Key to return to display the mistaken operand and input the operand again.

Note a) Counters are input in the same basic way as timers except the CNT Key is pressed instead of the TIM Key.

b) Timer and counter SVs are input in BCD, so it isn't necessary to press the CONT/# Key.

- Input the third instruction and its operands. First input the instruction by pressing the FUN Key and then the function code (21 in this case).

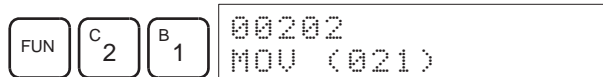

To input the differentiated version of an instruction, press the NOT Key after the function code (FUN 2 1 NOT). The "@" symbol will be displayed next to differentiated instructions. Press the NOT Key again to change back the instruction back to a non-differentiated instruction. The "@" symbol will disappear.

To change an instruction after it has been entered, simply scroll through the program until the desired instruction is displayed and press the NOT Key. The "@" symbol should be displayed next to the instruction.

- Press the WRITE Key to write the instruction to Program Memory. The input display for the first operand will be displayed.

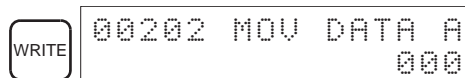

• Writing Hexadecimal, BCD Constant

- Input the first operand.

The operands of MOV (21) are normally word addresses, but a constant can be input by pressing the CONT/# Key first. When the CONT/# Key is pressed, the display will change to "#0000," indicating that a constant can be entered.

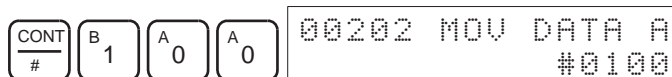

Press the WRITE Key to write the instruction to Program Memory. The input display for the second operand will appear.

WRITE 00202 MOV DATA E
000

Note The operands of MOV(21) can be word addresses, so the CONT/# Key must be pressed to input a constant.

• Writing a Word Address

11. Input the second operand.

*EM B A
LR 1 0 00202 MOV DATA E
LR 10

Press the WRITE Key to write the instruction to Program Memory. The next program address will be displayed.

WRITE 00203READ
NOP (000)

Note When the default display value is “000”, a word address can be input immediately without pressing the Shift and CH/# Keys.

12. Input the next instruction.

FUN F A
5 0 00203
ADB (050)

Press the WRITE Key to write the instruction to Program Memory.

WRITE 00203 ADB DATA A
000

• Writing an Unsigned Decimal Number

13. The first operand is input as an unsigned integer.

CONT SHIFT TR NOT 00203 ADB DATA A
000000

Input the value of the operand from 0 to 65535.

C F 00203 ADB DATA A
2 5 6 #00256

Note If an erroneous input is made, press the CLR Key to restore the status prior to the input. Then enter the correct input.

14. Restore the hexadecimal display.

SHIFT TR 00203 ADB DATA A
#0100

Note If an input is made outside of the permissible range, a buzzer will sound and the hexadecimal display will not be displayed.

WRITE 00203 ADB DATA E
000

15. The second operand is input as a signed integer.

CONT SHIFT TR 00203 ADB DATA E
+00000

Input the value of the operand from -32,768 to 32,767. Use the SET Key to input a positive number, and use the RESET Key to input a negative number.

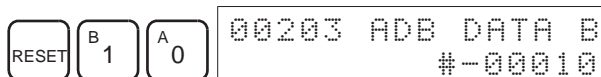

Note If an erroneous input is made, press the CLR Key to restore the status prior to the input. Then enter the correct input.

16. Restore the hexadecimal display.

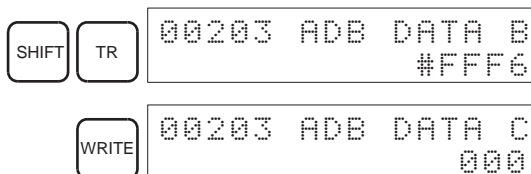

• Writing a Word Address (DM 0000)

17. Input the final operand and then press the WRITE Key. (It isn't necessary to input leading zeroes.)

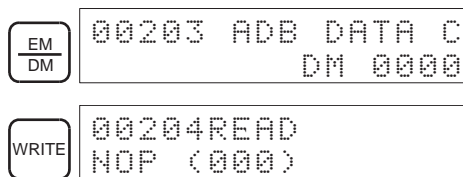

7-2-10 Instruction Search

This operation is used to find occurrences of the specified instruction in the program and is possible in any mode.

RUN	MONITOR	PROGRAM
OK	OK	OK

The ON/OFF status of any displayed bit will be shown if the PLC is in RUN or MONITOR mode.

- 1,2,3...
1. Press the CLR Key to bring up the initial display.
 2. Input the address from which the search will begin and press the Down Arrow Key. It is not necessary to input leading zeroes.

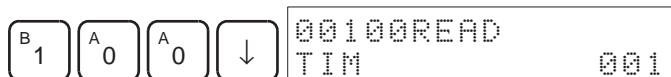

3. Input the instruction to be found and press the SRCH Key. In this case, the search is for OUT 01000.

In this case, the next OUT 01000 instruction is at address 200, as shown below.



4. Press the Down Arrow Key to display the instruction's operands or press the SRCH Key to search for the next occurrence of the instruction.
5. The search will continue until an END instruction or the end of Program Memory is reached. In this case, an END instruction was reached at address 397.

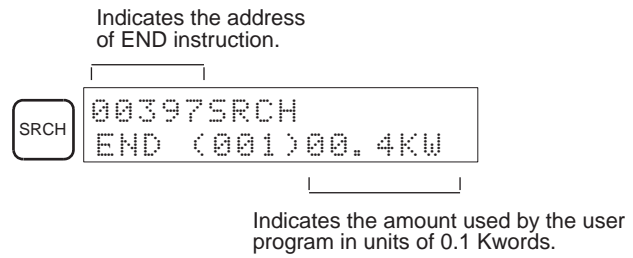

7-2-11 Bit Operand Search

This operation is used to find occurrences of the specified operand bit in the program and is possible in any mode.

RUN	MONITOR	PROGRAM
OK	OK	OK

The ON/OFF status of any displayed bit will be shown if the PLC is in RUN or MONITOR mode.

1,2,3...

1. Press the CLR Key to bring up the initial display.
2. Input the operand address. It is not necessary to input leading zeroes.

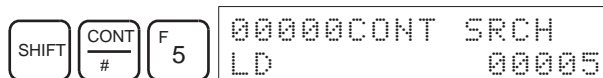

3. Press the SRCH Key to begin the search.



4. Press the SRCH Key to search for the next occurrence of the operand bit.



5. The search will continue until an END instruction or the end of Program Memory is reached. In this case, an END instruction was reached.

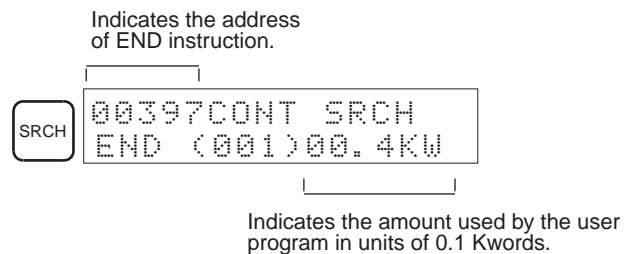

7-2-12 Inserting and Deleting Instructions

This operation is used to insert or delete instructions from the program. It is possible in PROGRAM mode only.

RUN	MONITOR	PROGRAM
No	No	OK

To demonstrate this operation, an IR 00105 NO condition will be inserted at program address 00206 and an IR 00103 NO condition deleted from address 00205, as shown in the following diagram.

Original Program

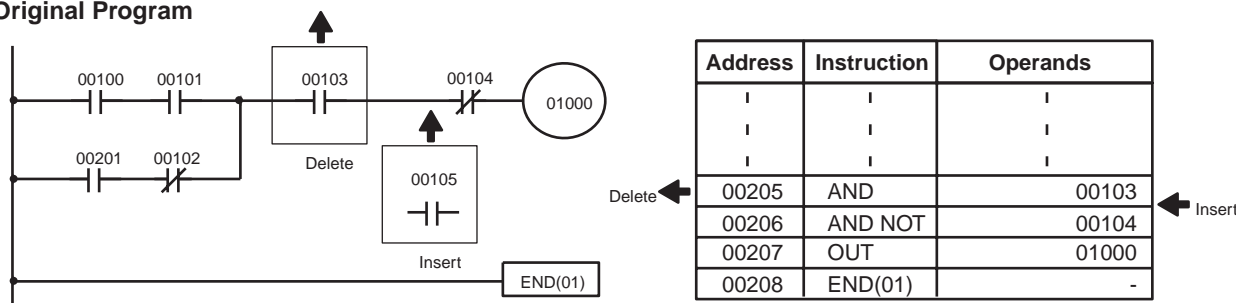

Insertion

Follow the procedure below to insert the IR 00105 NO condition at address 00206.

1,2,3...

1. Press the CLR Key to bring up the initial display.
2. Input the address where the NO condition will be inserted and press the Down Arrow Key. It is not necessary to input leading zeroes.



3. Input the new instruction and press the INS Key.



4. Press the Down Arrow Key to insert the new instruction.

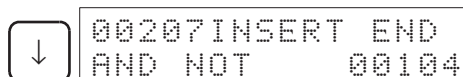

Note For instructions that require more operands (such as set values), input the operands and then press the WRITE Key.

Deletion

Follow the procedure below to delete the IR 00103 NO condition at address 00205.

1,2,3...

1. Press the CLR Key to bring up the initial display.
2. Input the address where the NO condition will be deleted and press the Down Arrow Key. It is not necessary to input leading zeroes.



3. Press the DEL Key.

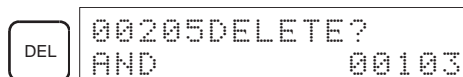

4. Press the Up Arrow Key to delete the specified instruction.

If the instruction has more operands, the operands will be deleted automatically with the instruction.

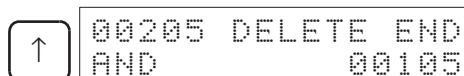

After completing the insertion and deletion procedures, use the Up and Down Arrow Keys to scroll through the program and verify that it has been changed correctly, as shown in the following diagram.

Corrected Program

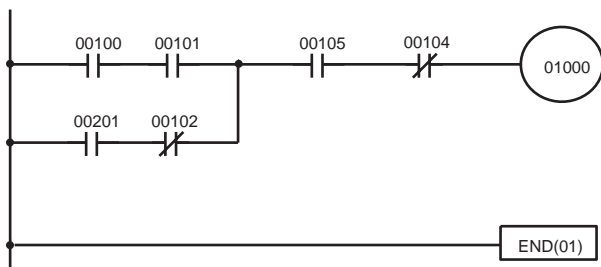

Address	Instruction	Operands
00205	AND	00105
00206	AND NOT	00104
00207	OUT	01000
00208	END(01)	-

7-2-13 Checking the Program

This operation checks for programming errors and displays the program address and error when errors are found. It is possible in PROGRAM mode only.

RUN	MONITOR	PROGRAM
No	No	OK

1,2,3...

1. Press the CLR Key to bring up the initial display.
2. Press the SRCH Key. An input prompt will appear requesting the desired check level.

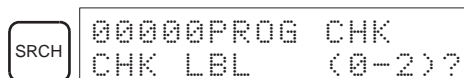

3. Input the desired check level (0, 1, or 2). The program check will begin when the check level is input, and the first error found will be displayed.

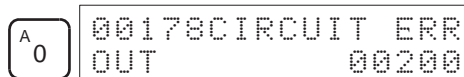

4. Press the SRCH Key to continue the search. The next error will be displayed. Continue pressing the SRCH Key to continue the search.

The search will continue until an END instruction or the end of Program Memory is reached. A display like this will appear if the end of Program Memory is reached:

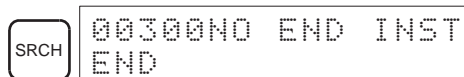

A display like this will appear if an END instruction is reached:



No more errors exist if the END instruction is displayed.

If errors are displayed, edit the program to correct the errors and check the program again. Continue checking the program by pressing the SRCH Key again until all errors have been corrected.

7-2-14 Bit, Digit, Word Monitor

This operation is used to monitor the status of up to 16 bits and words, although only 3 can be shown on the display at any one time. Operation is possible in any mode.

RUN	MONITOR	PROGRAM
OK	OK	OK

Program Read then Monitor

1,2,3...

When a program address is being displayed, the status of the bit or word in that address can be monitored by pressing the MONTR Key.

1. Press the CLR Key to bring up the initial display.
2. Input the desired program address and press the Down Arrow Key.

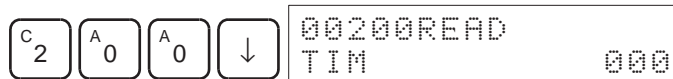

3. Press the MONTR Key to begin monitoring.

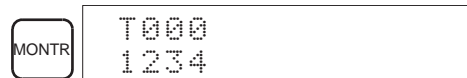

If the status of a bit is being monitored, that bit's status can be changed using the Force Set/Reset operation. Refer to 7-2-26 *Force Set, Reset* for details.

If the status of a word is being monitored, that word's value can be changed using the Hexadecimal/BCD Data Modification operation. Refer to 7-2-22 *Hexadecimal, BCD Data Modification*, 7-2-23 *Binary Data Modification*, 7-2-24 *Signed Decimal Data Modification*, and 7-2-25 *Unsigned Decimal Data Modification* for details.

4. Press the CLR Key to end monitoring.

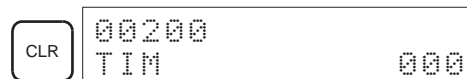

Bit Monitor

1,2,3...

Follow the procedure below to monitor the status of a particular bit.

1. Press the CLR Key to bring up the initial display.
2. Input the bit address of the desired bit and press the MONTR Key.

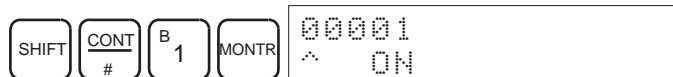

The Up or Down Arrow Key can be pressed to display the status of the previous or next bit.

The displayed bit's status can be changed using the Force Set/Reset operation. Refer to 7-2-26 *Force Set, Reset* for details.

3. Press the CLR Key to end monitoring.

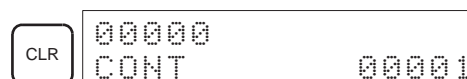

Word Monitor

Follow the procedure below to monitor the status of a particular word.

1,2,3...

1. Press the CLR Key to bring up the initial display.
2. Input the word address of the desired word.



3. Press the MONTR Key to begin monitoring.

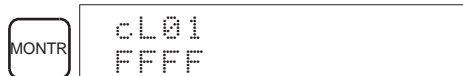

The Up or Down Arrow Key can be pressed to display the status of the previous or next word.

The displayed word's status can be changed using the Hexadecimal/BCD Data Modification operation. Refer to Refer to 7-2-22 Hexadecimal, BCD Data Modification, 7-2-23 Binary Data Modification, 7-2-24 Signed Decimal Data Modification, and 7-2-25 Unsigned Decimal Data Modification for details.

4. Press the CLR Key to end monitoring.

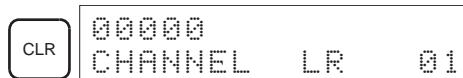

Note The operating mode can be changed without altering the current monitor display by holding down the SHIFT Key and then changing the operating mode.

Multiple Address Monitoring

The status of up to six bits and words can be monitored simultaneously, although only three can be shown on the display at any one time.

1,2,3...

1. Press the CLR Key to bring up the initial display.
2. Input the address of the first bit or word and press the MONTR Key.

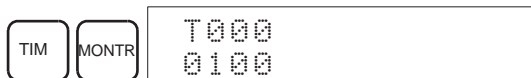

3. Repeat step 2 up to 6 times to display the next addresses to be monitored.

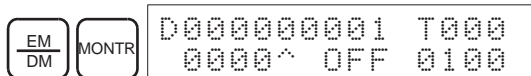
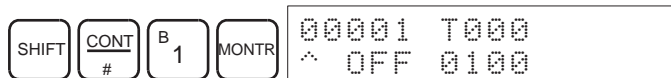

If 4 or more bits and words are being monitored, the bits and words that do not appear on the display can be displayed by pressing the MONTR Key. If the MONTR Key is pressed alone, the display will shift to the right.

If more than six bits and words are input, monitoring of the bit or word input first will be canceled.

4. Press the CLR Key to stop monitoring the leftmost bit or word and clear it from the display.

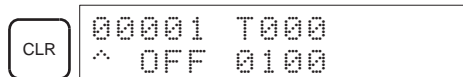

5. Press the SHIFT and CLR Keys to end monitoring altogether.



Note Press the SHIFT Key, CLR Key, and then CLR Key again to return to the initial Programming Console display with the multiple address monitoring state unchanged. Press the SHIFT Key and then the MONTR Key from the initial display to return to the multiple address monitoring state. The monitoring states can be retained for 6 bits and words. The operating mode can be changed without altering the current monitor display by holding down the SHIFT Key and then changing the operating mode.

7-2-15 Differentiation Monitor

This operation is used to monitor the up or down differentiation status of a particular bit. When detected, the up or down differentiation will be displayed and the buzzer will sound. It is possible in any mode.

RUN	MONITOR	PROGRAM
OK	OK	OK

1,2,3...

1. Monitor the status of the desired bit according to the procedure described in 7-2-14 *Bit, Digit, Word Monitor*. If 2 or more bits are being monitored, the desired bit should be leftmost on the display.

In this case the differentiation status of LR 00 will be monitored.



2. To specify up-differentiation monitoring, press the SHIFT and then the Up Arrow Key. The symbols “U@” will appear.

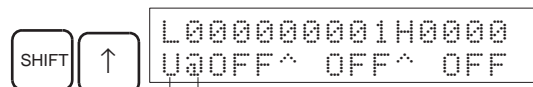

Indicates waiting for the bit to turn ON.

To specify down-differentiation monitoring, press the SHIFT and then the Down Arrow Key. The symbols “D@” will appear.

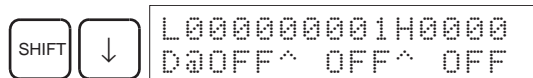

3. The buzzer will sound when the specified bit goes from off to on (for up-differentiation) or from on to off (for down-differentiation).

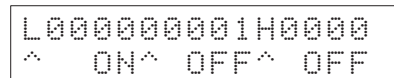

Note The buzzer will not sound if it has been turned off.

4. Press the CLR Key to end differentiation monitoring and return to the normal monitoring display.

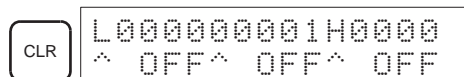

7-2-16 Binary Monitor

This operation is used to monitor the ON/OFF status of any word's 16 bits. It is possible in any mode.

RUN	MONITOR	PROGRAM
OK	OK	OK

1,2,3...

1. Monitor the status of the desired word according to the procedure described in 7-2-14 *Bit, Digit, Word Monitor*. The desired word should be leftmost on the display if 2 or more words are being monitored.



(Word monitor)

2. Press the SHIFT and then the MONTR Key to begin binary monitoring. The ON/OFF status of the selected word's 16 bits will be shown along the bottom of the display. A 1 indicates a bit is on, and a 0 indicates it is off.

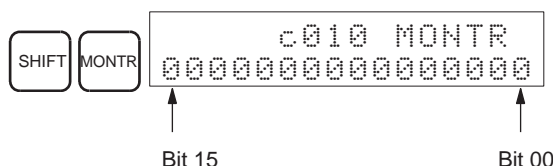

The status of force-set bits is indicated by "S," and the status of a force-reset bits is indicated by "R," as shown below.

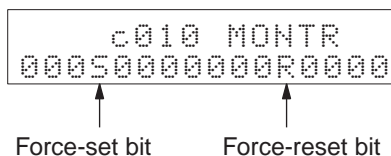

Note a) The status of displayed bits can be changed at this point. Refer to 7-2-23 *Binary Data Modification* for details.

b) The Up or Down Arrow Key can be pressed to display the status of the previous or next word's bits.

3. Press the CLR Key to end binary monitoring and return to the normal monitoring display.

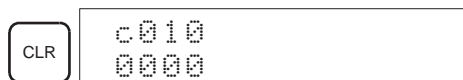

7-2-17 Three-Word Monitor

This operation is used to monitor the status of three consecutive words. It is possible in any mode.

RUN	MONITOR	PROGRAM
OK	OK	OK

1,2,3...

1. Monitor the status of the first of the three words according to the procedure described in 7-2-14 *Bit, Digit, Word Monitor*.
If 2 or more words are being monitored, the desired first word should be leftmost on the display.



(Word monitor)

- Press the EXT Key to begin 3-word monitoring. The status of the selected word and the next two words will be displayed, as shown below. In this case, DM 0000 was selected.

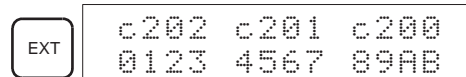

The Up and Down Arrow Keys can be used to shift one address up or down.

The status of the displayed words can be changed at this point. Refer to 7-2-20 *Three-Word Data Modification*.

The display can be changed to display ASCII text, which is useful when three consecutive words containing an ASCII message are displayed. Refer to 7-2-28 *Hex-ASCII Display Change*.

- Press the CLR Key to end 3-word monitoring and return to the normal monitoring display. The rightmost word on the 3-word monitor display will be monitored.

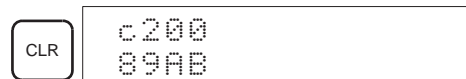

Note The operating mode can be changed without altering the current monitor display by holding down the SHIFT Key and then changing the operating mode.

7-2-18 Signed Decimal Monitor

This operation converts the contents of the specified word from signed hexadecimal (two's complement format) to signed decimal for display. The operation can be executed while using I/O monitoring, multiple address monitoring or 3-word monitoring.

RUN	MONITOR	PROGRAM
OK	OK	OK

1,2,3...

- Monitor the word that is to be used for decimal monitor with sign. During multiple address monitoring, the leftmost word will be converted.

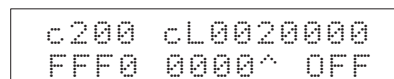

(Multiple address monitor)

- Press the SHIFT+TR Keys to display the leftmost word as signed decimal.

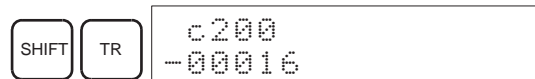

At this point, the contents of the displayed word can be changed with a signed-decimal input. Refer to 7-2-24 *Signed Decimal Data Modification*.

- Press the CLR Key or the SHIFT+TR Keys to end the unsigned decimal display and return to normal monitoring.

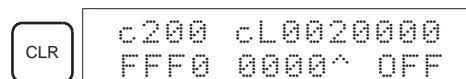

7-2-19 Unsigned Decimal Monitor

This operation is used to convert hexadecimal data in a word to unsigned decimal for display. The operation can be executed while using I/O monitoring, multiple address monitoring or 3-word monitoring.

RUN	MONITOR	PROGRAM
OK	OK	OK

- 1,2,3... 1. Monitor the word that is to be used for decimal monitor without sign. During multiple address monitoring, the leftmost word will be converted.

```
c200 cL0020000
FFF0 0000^ OFF
```

Multiple address monitoring

2. Press the SHIFT+TR+NOT Keys to display the leftmost word as unsigned decimal.

SHIFT	TR	NOT	c200 65520
-------	----	-----	---------------

At this point, the contents of the displayed word can be changed with an unsigned-decimal input. Refer to 7-2-25 *Unsigned Decimal Data Modification*.

3. Press the CLR Key or the SHIFT+TR Keys to end the unsigned decimal display and return to normal monitoring.

CLR	c200 cL0020000 FFF0 0000^ OFF
-----	----------------------------------

7-2-20 Three-Word Data Modification

This operation is used to change the contents of one or more of the 3 consecutive words displayed in the Three-Word Monitor operation. It is possible in MONITOR or PROGRAM mode only.

RUN	MONITOR	PROGRAM
No	OK	OK

Caution Before changing the contents of I/O memory, be sure that the changes will not cause equipment to operate unexpectedly or dangerously. In particular, take care when changing the status of output bits. The PLC continues to refresh I/O bits even if the PLC is in PROGRAM mode, so devices connected to output points on the CPU Board or Expansion I/O Boards may operate unexpectedly.

- 1,2,3... 1. Monitor the status of the desired words according to the procedure described 7-2-17 *Three-Word Monitor*.

```
D0002D0001D0000
0123 4567 89AB
```

(Three-word monitor)

2. Press the CHG Key to begin 3-word data modification. The cursor will appear next to the contents of the leftmost word.

CHG	D0002 3CH CHG? ■0123 4567 89AB
-----	-----------------------------------

3. Input the new value for the leftmost word on the display and press the CHG Key if more changes will be made.
(Input the new value and press the WRITE Key to write the changes in memory if no more changes will be made.)



- Input the new value for the middle word on the display and press the CHG Key if the rightmost word will be changed. Input the new value and press the WRITE Key to write the changes in memory if the rightmost word will not be changed. (In this case, it will not.)

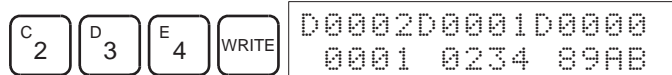

Note If the CLR Key is pressed before the WRITE Key, the operation will be cancelled and the 3-word monitor display will return without any changes in data memory.

7-2-21 Changing Timer, Counter SV

There are two operations that can be used to change the SV of a timer or counter. They are possible in MONITOR or PROGRAM mode only. In MONITOR mode, the SV can be changed while the program is being executed.

RUN	MONITOR	PROGRAM
No	OK	OK

The timer or counter SV can be changed either by inputting a new value or by incrementing or decrementing the current SV.

Inputting a New SV Constant

This operation can be used to input a new SV constant, as well as to change an SV from a constant to a word address designation and vice versa. The following examples show how to input a new SV constant and how to change the SV from a constant to an address.

1,2,3...

- Press the CLR Key to bring up the initial display.
- Display the desired timer or counter.

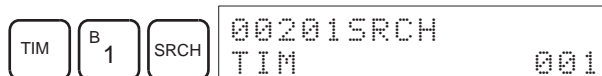

- Press the Down Arrow Key and then the CHG Key.

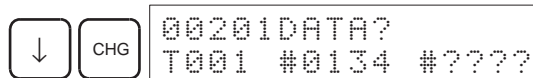

- At this point a new SV constant can be input or the SV constant can be changed to a word address designation
 - To input a new SV constant, input the constant and press the WRITE Key.

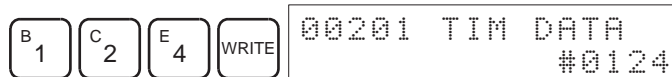

- To change to a word address designation, input the word address and press the WRITE Key.



Incrementing and Decrementing a Constant

This operation can be used to increment and decrement an SV constant. It is possible only when the SV has been entered as a constant.

1,2,3...

1. Press the CLR Key to bring up the initial display.
2. Display the desired timer or counter.

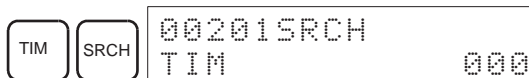

3. Press the Down Arrow, CHG, and then the EXT Key.

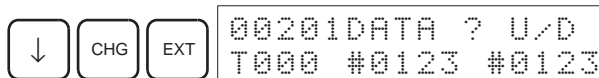

The constant on the left is the old SV and the constant on the right will become the new SV constant in step 5.

4. Press the Up and Down Arrow Keys to increment and decrement the constant on the right. (In this case the SV is incremented once.)

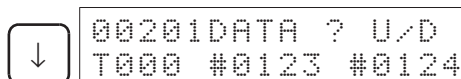

5. Press the CLR Key twice to change the timer's SV to the new value.

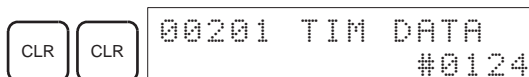

7-2-22 Hexadecimal, BCD Data Modification

This operation is used to change the BCD or hexadecimal value of a word being monitored using the procedure described in 7-2-14 *Bit, Digit, Word Monitor*. It is possible in MONITOR or PROGRAM mode only.

RUN	MONITOR	PROGRAM
No	OK	OK

Words SR 253 to SR 255 cannot be changed.

Caution Before changing the contents of I/O memory, be sure that the changes will not cause equipment to operate unexpectedly or dangerously. In particular, take care when changing the status of output bits. The PLC continues to refresh I/O bits even if the PLC is in PROGRAM mode, so devices connected to output points on the CPU Board or Expansion I/O Boards may operate unexpectedly.

1,2,3...

1. Monitor the status of the desired word according to the procedure described in 7-2-14 *Bit, Digit, Word Monitor*. If two or more words are being monitored, the desired word should be leftmost on the display.



(Word monitor)

2. Press the CHG Key to begin hexadecimal, BCD data modification.

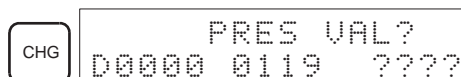

3. Input the new PV and press the WRITE Key to change the PV.
The operation will end and the normal monitoring display will return when the WRITE Key is pressed.

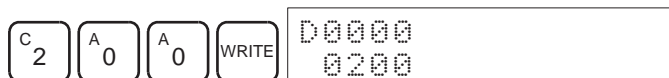

7-2-23 Binary Data Modification

This operation is used to change the status of a word's bits when the word is monitored using the procedure described in 7-2-16 *Binary Monitor*. It is possible in MONITOR or PROGRAM mode only.

RUN	MONITOR	PROGRAM
No	OK	OK

Bits SR 25300 to SR 25507 and timer/counter flags cannot be changed.

Caution Before changing the contents of I/O memory, be sure that the changes will not cause equipment to operate unexpectedly or dangerously. In particular, take care when changing the status of output bits. The PLC continues to refresh I/O bits even if the PLC is in PROGRAM mode, so devices connected to output points on the CPU Board or Expansion I/O Boards may operate unexpectedly.

- 1,2,3... 1. Monitor the status of the desired word according to the procedure described 7-2-16 *Binary Monitor*.

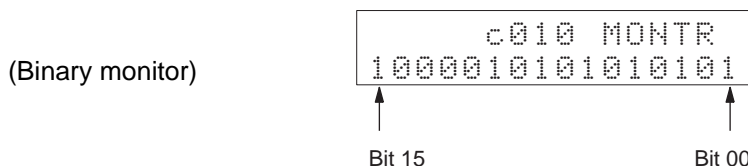

2. Press the CHG Key to begin binary data modification.

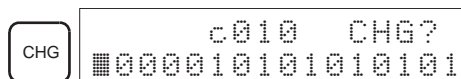

A flashing cursor will appear over bit 15. The cursor indicates which bit can be changed.

3. Three sets of keys are used to move the cursor and change bit status:
- Use the Up and Down Arrow Keys to move the cursor to the left and right.

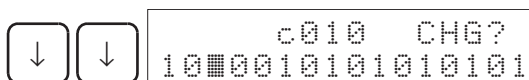

- Use the 1 and 0 Keys to change a bit's status to on or off. The cursor will move one bit to the right after one of these keys is pressed.

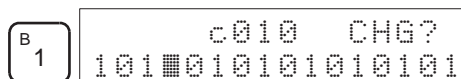

- Use the SHIFT+SET and SHIFT+RESET Keys to force-set or force-reset a bit's status. The cursor will move one bit to the right after one of these keys is pressed. The NOT Key will clear force-set or force-reset status.

Note Bits in the DM Area cannot be force-set or force-reset.

4. Press the WRITE Key to write the changes in memory and return to the binary monitor.

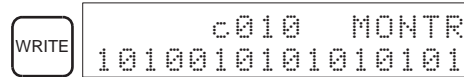

7-2-24 Signed Decimal Data Modification

This operation is used to change the decimal value of a word being monitored as signed decimal data, within a range of -32,768 to 32,767. The contents of the specified word are converted automatically to signed hexadecimal (two's complement format).

Words SR 253 to SR 255 cannot be changed.

RUN	MONITOR	PROGRAM
No	OK	OK

Caution Before changing the contents of I/O memory, be sure that the changes will not cause equipment to operate unexpectedly or dangerously. In particular, take care when changing the status of output bits. The PLC continues to refresh I/O bits even if the PLC is in PROGRAM mode, so devices connected to output points on the CPU Board or Expansion I/O Boards may operate unexpectedly.

- 1,2,3... 1. Monitor (signed decimal) the status of the word for which the present value is to be changed.



(Signed decimal monitor)

2. Press the CHG Key to begin decimal data modification.

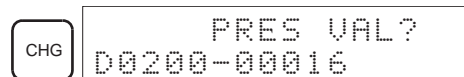

3. Input the new PV and press the WRITE Key to change the PV. The operation will end and the signed-decimal monitoring display will return when the WRITE Key is pressed.

The PV can be set within a range of -32,768 and 32,767. Use the SET Key to input a positive number, and use the RESET Key to input a negative number.



If an erroneous input has been made, press the CLR Key to restore the status prior to the input. Then enter the correct input.

The buzzer will sound if a value outside the specified range is input, allowing no writing.

7-2-25 Unsigned Decimal Data Modification

This operation is used to change the decimal value of a word being monitored as unsigned decimal data, within a range of 0 to 65,535. A change into hexadecimal data is made automatically.

Words SR 253 to SR 255 cannot be changed.

RUN	MONITOR	PROGRAM
No	OK	OK

Caution Before changing the contents of I/O memory, be sure that the changes will not cause equipment to operate unexpectedly or dangerously. In particular, take care when changing the status of output bits. The PLC continues to refresh I/O bits even if the PLC is in PROGRAM mode, so devices connected to output points on the CPU Board or Expansion I/O Boards may operate unexpectedly.

- 1,2,3...**
1. Monitor (unsigned decimal) the status of the word for which the present value is to be changed.

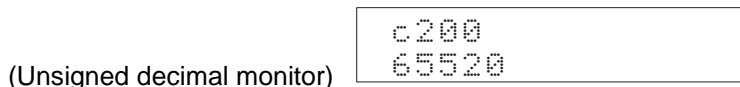

2. Press the CHG Key to begin decimal data modification.

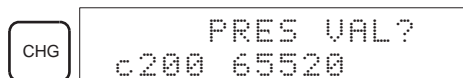

3. Input the new PV and press the WRITE Key to change the PV. The operation will end and the decimal-without-sign monitoring display will return when the WRITE Key is pressed.

The PV can be set within a range of 0 to 65,535.



If an erroneous input has been made, press the CLR Key to restore the status prior to the input. Then enter the correct input.

The buzzer will sound if a value outside the specified range is input, allowing no writing.

7-2-26 Force Set, Reset

This operation is used to force bits ON (force set) or OFF (force reset) and is useful when debugging the program or checking output wiring. It is possible in MONITOR or PROGRAM mode only.

RUN	MONITOR	PROGRAM
No	OK	OK

Caution Before changing the contents of I/O memory, be sure that the changes will not cause equipment to operate unexpectedly or dangerously. In particular, take care when changing the status of output bits. The PLC continues to refresh I/O bits even if the PLC is in PROGRAM mode, so devices connected to output points on the CPU Board or Expansion I/O Boards may operate unexpectedly.

- 1,2,3...**
1. Monitor the status of the desired bit according to the procedure described in 7-2-14 *Bit, Digit, Word Monitor*. If two or more words are being monitored, the desired bit should be leftmost on the display.

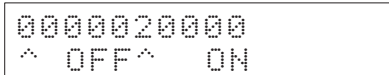

(Multiple address monitor)

- Press the SET Key to force the bit ON or press the RESET Key to force the bit OFF.

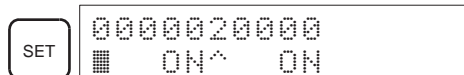

The cursor in the lower left corner of the display indicates that the force set/reset is in progress. Bit status will remain ON or OFF only as long as the key is held down; the original status will return one cycle after the key is released.

- Press the SHIFT and SET Keys or SHIFT and RESET Keys to maintain the status of the bit after the key is released. In this case, the force-set status is indicated by an “S” and the force-reset status is indicated by an “R.”

To return the bit to its original status, press the NOT Key or perform the Clear Force Set/Reset operation. Refer to 7-2-27 *Clear Force Set/Reset* for details.

Forced status will also be cleared in the following cases:

- When the PLC’s operating mode is changed (although the forced status will not be cleared when the mode is changed from PROGRAM to MONITOR if SR 25211 is ON)
- When the PLC stops because a fatal error occurred
- When the PLC stops because of a power interruption
- When the Clear Force Set/Reset Operation is performed

7-2-27 Clear Force Set/Reset

This operation is used to restore the status of all bits which have been force set or reset. It is possible in MONITOR or PROGRAM mode only.

RUN	MONITOR	PROGRAM
No	OK	OK

⚠ Caution Before changing the contents of I/O memory, be sure that the changes will not cause equipment to operate unexpectedly or dangerously. In particular, take care when changing the status of output bits. The PLC continues to refresh I/O bits even if the PLC is in PROGRAM mode, so devices connected to output points on the CPU Board or Expansion I/O Boards may operate unexpectedly.

- 1,2,3...**
- Press the CLR Key to bring up the initial display.
 - Press the SET and then the RESET Key. A confirmation message will appear.

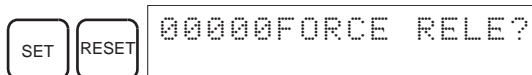

Note If you mistakenly press the wrong key, press CLR and start again from the beginning.

- Press the NOT Key to clear the force-set/reset status of bits in all data areas.

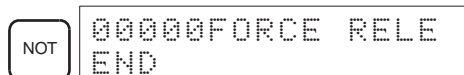

7-2-28 Hex-ASCII Display Change

This operation is used to convert word data displays back and forth between 4-digit hexadecimal data and ASCII. It is possible in any mode.

The displayed PV of the timer or counter cannot be changed.

RUN	MONITOR	PROGRAM
OK	OK	OK

- 1,2,3... 1. Monitor the status of the desired word(s) according to the procedure described in 7-2-14 *Bit, Digit, Word Monitor*. While the multiple addresses are being monitored, the leftmost word is subject to change.

```
D00000D00001
 4142 3031
```

(Multiple address monitor)

2. Press the TR Key to switch to ASCII display. The display will toggle between hexadecimal and ASCII displays each time the TR Key is pressed.

TR

```
D00000D00001
"AB" 3031
```

TR

```
D00000D00001
 4142 3031
```

- Note**
1. A message contained in three words can be displayed by using ASCII display in combination with the Three-word monitor operation.
 2. The Hexadecimal, BCD Data Modification Operation can be used while displaying ASCII data. Input values in 4-digit hexadecimal.

7-2-29 Displaying the Cycle Time

This operation is used to display the current average cycle time (scan time). It is possible only in RUN or MONITOR mode while the program is being executed.

RUN	MONITOR	PROGRAM
OK	OK	No

- 1,2,3... 1. Press the CLR Key to bring up the initial display.
2. Press the MONTR Key to display the cycle time.

MONTR

```
000000SCAN TIME
          012.1MS
```

"MS" in the display indicates the unit "ms" for the cycle time.

There might be differences in displayed values when the MONTR Key is pressed repeatedly. These differences are caused by changing execution conditions.

7-2-30 Reading and Setting the Clock

This operation is used to read or set the CPU's clock. The clock can be read in any mode, but can be set in MONITOR or PROGRAM mode only.

Operation	RUN	MONITOR	PROGRAM
Read clock	OK	OK	OK
Set clock	No	OK	OK

- 1,2,3...
1. Press the CLR Key to bring up the initial display.
 2. Press the FUN Key, SHIFT Key, and then the MONTR Key to display the date and time.

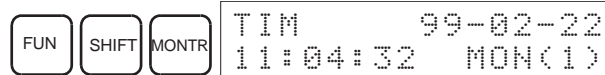

3. Press the CHG Key to change the date and/or time.

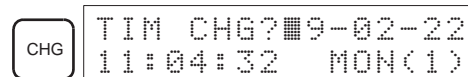

The digit that can be changed will flash. If necessary, input a new value with the Up and Down Arrow Keys or Numeric Keys. Press the CHG Key to move the cursor to the next digit. The following table shows the setting ranges for each value.

Year	Month	Day	Hour	Minute	Second	Day-of-week
00 to 99	01 to 12	01 to 31	00 to 23	00 to 59	00 to 59	0 to 6 (SUN to SAT)

4. Press the WRITE Key to write the new value.

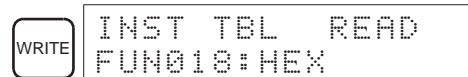

Press the CLR Key to return to the initial display.

7-3 Programming Example

This section demonstrates all of the steps needed to write a program with the Programming Console.

7-3-1 Preparatory Operations

Use the following procedure when writing a program to the CPM2B for the first time.

- 1,2,3...
1. Set the Programming Console's mode switch to PROGRAM mode and turn on the CPM2B's power supply. The password input display will appear on the Programming Console.



2. Enter the password by pressing the CLR and then the MONTR Key.



3. Clear the CPM2B's memory by pressing the CLR, SET, NOT, RESET, and then the MONTR Key. Press the CLR Key several times if memory errors are displayed.

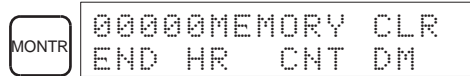
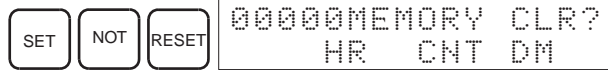

4. Display and clear error messages by pressing the CLR, FUN, and then the MONTR Key. Continue pressing the MONTR Key until all error messages have been cleared.

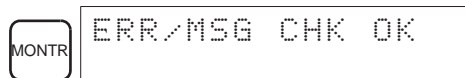
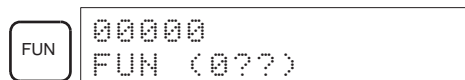
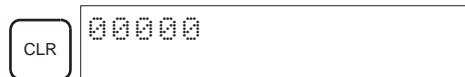

5. Press the CLR Key to bring up the initial programming display (program address 00000). The new program can be written at this point.

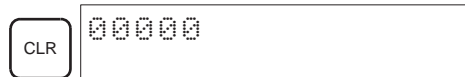

⚠ Caution Check the system thoroughly before starting or stopping the CPM2B to prevent any accidents that might occur when the program is first started.

7-3-2 Example Program

The following ladder program will be used to demonstrate how to write a program with the Programming Console. This program makes output IR 01000 flicker ON/OFF (one second ON, one second OFF) ten times after input IR 00000 is turned ON.

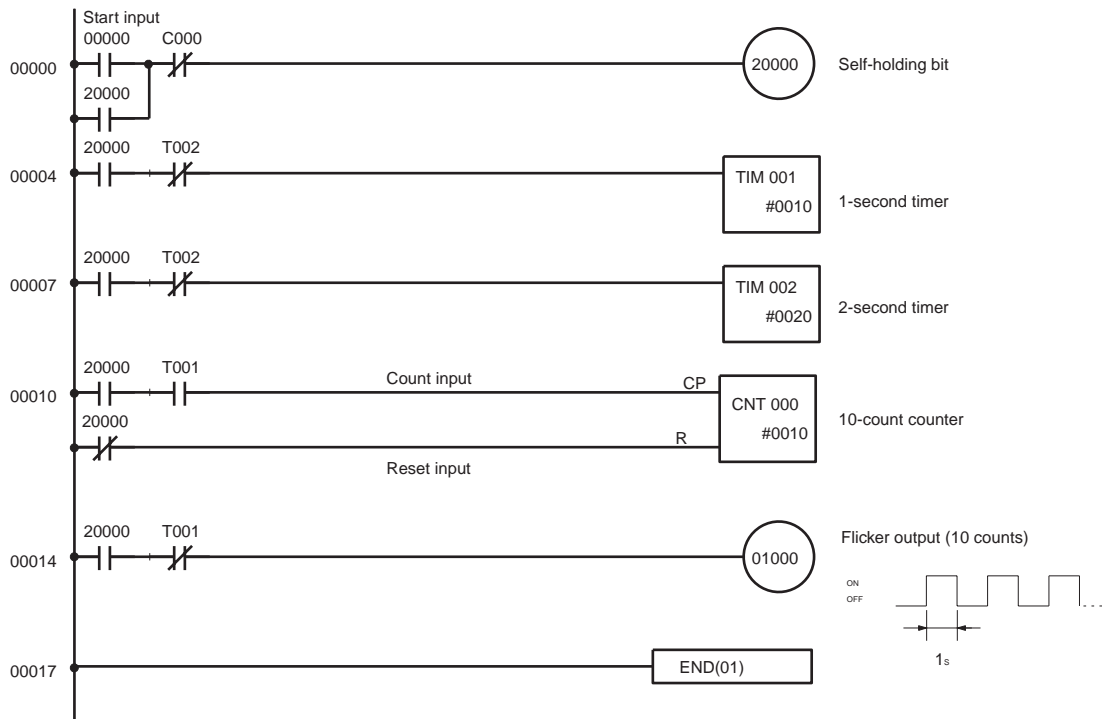

The mnemonic list for the example program is shown in the following table. The steps required to enter this program from a Programming Console are described in 7-3-3 Programming Procedures.

Address	Instruction	Data	Programming example procedures in 7-3-3 Programming Procedures
00000	LD	00000	(1) Self-holding bit
00001	OR	20000	
00002	AND NOT	C 000	
00003	OUT	20000	
00004	LD	20000	(2) 1-second timer
00005	AND NOT	T 002	
00006	TIM	001 # 0010	
00007	LD	20000	(3) 2-second timer
00008	AND NOT	T 002	
00009	TIM	002 # 0020	
00010	LD	20000	(4) 10-count counter
00011	AND	T 001	
00012	LD NOT	20000	
00013	CNT	000 # 0010	
00014	LD	20000	(5) Flicker output (10 counts)
00015	AND NOT	T 001	
00016	OUT	01000	
00017	END (01)	---	(6) END(01) instruction

7-3-3 Programming Procedures

The example program will be written to the CPM2B according to the mnemonic list in 7-3-2 *Example Program*. The procedure is performed beginning with the initial display. (Clear the memory before entering a new program.)

Note If an error occurs while inputting the program, refer to the *Programming Manual* for details on correcting the error.

(1) Inputting the Self-holding Bit

- 1,2,3... 1. Input the normally open condition IR 00000.
(It isn't necessary to input leading zeroes.)

LD HI	00000 LD	00000
----------	-------------	-------

WRITE	00001READ NOP (000)
-------	------------------------

2. Input the OR condition IR 20000.

OR HI	C 2	A 0	A 0	A 0	A 0	00001 OR	20000
----------	-----	-----	-----	-----	-----	-------------	-------

WRITE	00002READ NOP (000)
-------	------------------------

3. Input the normally closed AND condition C000.
(It isn't necessary to input leading zeroes.)

AND HI	NOT	CNT	00002 AND NOT CNT 000
-----------	-----	-----	--------------------------

WRITE	00003READ NOP (000)
-------	------------------------

4. Input the OUT instruction IR 20000.

OUT	C 2	A 0	A 0	A 0	A 0	00003 OUT	20000
-----	-----	-----	-----	-----	-----	--------------	-------

WRITE	00004READ NOP (000)
-------	------------------------

(2) Inputting the One-second Timer

- 1,2,3... 1. Input the normally open condition IR 20000.

LD HI	C 2	A 0	A 0	A 0	A 0	00004 LD	20000
----------	-----	-----	-----	-----	-----	-------------	-------

WRITE	00005READ NOP (000)
-------	------------------------

- Input the normally closed AND condition T002.
(It isn't necessary to input leading zeroes.)



- Input the 1-second timer T001.

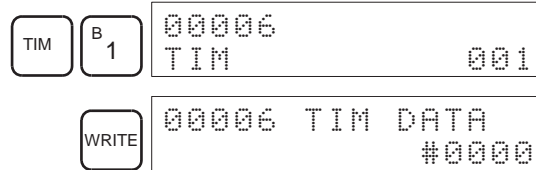

- Input the SV for T001 (#0010 = 1.0 s).

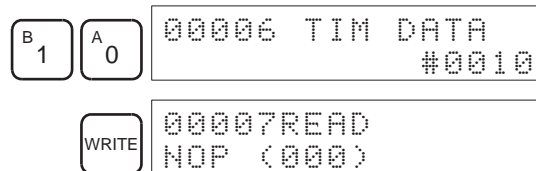

(3) Inputting the Two-second Timer

The following key operations are used to input the 2-second timer.

1,2,3...

- Input the normally open condition IR 20000.

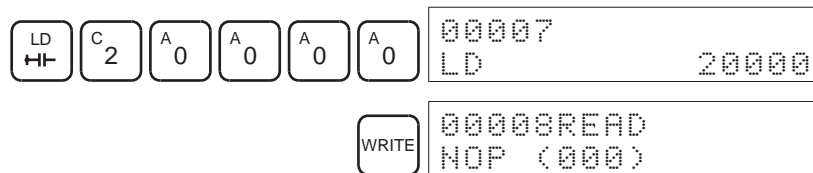

- Input the normally closed AND condition T002.
(It isn't necessary to input leading zeroes.)

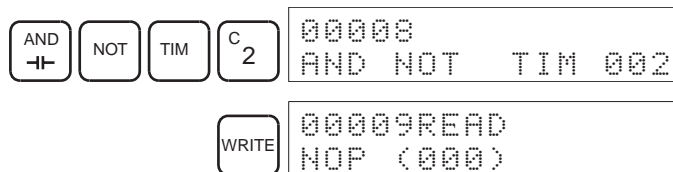

- Input the 2-second timer T002.

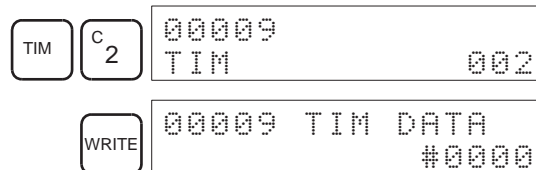

- Input the SV for T002 (#0020 = 2.0 s).

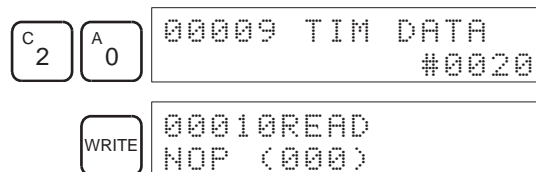

(4) Inputting the 10-count Counter

The following key operations are used to input the 10-count counter.

1,2,3...

1. Input the normally open condition IR 20000.

LD	LD	C 2	A 0	A 0	A 0	A 0	00010 LD	20000
							WRITE	00011READ NOP (000)

2. Input the normally open AND condition T001.
(It isn't necessary to input leading zeroes.)

AND	TIM	B 1	00011 AND	TIM 001
			WRITE	00012READ NOP (000)

3. Input the normally closed condition IR 20000.

LD	NOT	C 2	A 0	A 0	A 0	A 0	00012 LD NOT	20000
							WRITE	00013READ NOP (000)

4. Input the counter 000.

CNT	A 0	00013 CNT	000
		WRITE	00013 CNT DATA #0000

5. Input the SV for counter 000 (#0010 = 10 counts).

B 1	A 0	00013 CNT DATA #0010	
		WRITE	00014READ NOP (000)

(5) Inputting the Flicker Output

1,2,3...

1. Input the normally open condition IR 20000.

LD	LD	C 2	A 0	A 0	A 0	A 0	000014 LD	20000
							WRITE	00015READ NOP (000)

2. Input the normally closed AND condition T001.
(It isn't necessary to input leading zeroes.)

AND	NOT	TIM	B 1	00015 AND NOT	TIM 001
			WRITE	00016READ NOP (000)	

- Input the OUT instruction IR 01000.
(It isn't necessary to input leading zeroes.)

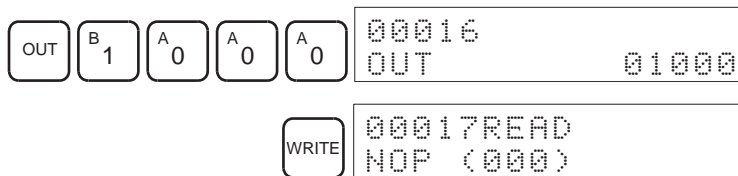

(6) Inputting the END(001) Instruction

Input END(01). (The display shows three digits in the function code, but only the last two digits are input for CPM2B PLCs.)

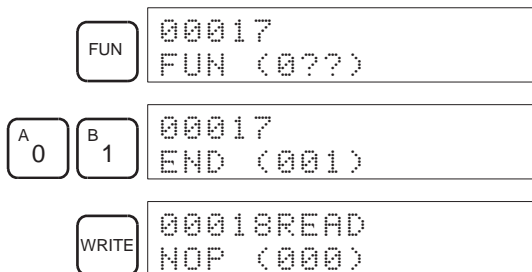

7-3-4 Checking the Program

Check the program syntax in PROGRAM mode to make sure that the program has been input correctly.

1,2,3...

- Press the CLR Key to bring up the initial display.

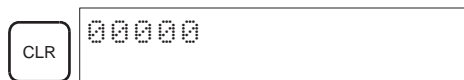

- Press the SRCH Key. An input prompt will appear requesting the desired check level.

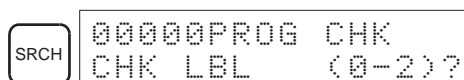

- Input the desired check level (0, 1, or 2). The program check will begin when the check level is input, and the first error found will be displayed. If no errors are found, the following display will appear.



Note Refer to the *Programming Manual* for details on check levels and the programming errors that may be displayed during a program check.

- Press the SRCH Key to continue the search. The next error will be displayed. Continue pressing the SRCH Key to continue the search.
The search will continue until an END(01) instruction or the end of Program Memory is reached.

If errors are displayed, edit the program to correct the errors and check the program again. Continue checking the program until all errors have been corrected.

7-3-5 Test Run in MONITOR Mode

Switch the CPM2B in MONITOR mode and check the operation of the program.

- 1,2,3... 1. Set the Programming Console's mode switch to MONITOR mode.

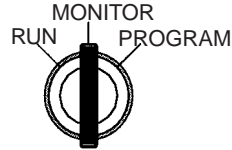

```
<MONITOR>    BZ
```

2. Press the CLR Key to bring up the initial display.

```
CLR  00000
```

3. Force-set the start input bit (IR 00000) from the Programming Console to start the program.

```
LD  00000
HL  LD      00000
```

```
MONTR 00000
^  OFF
```

```
SET  00000
■  ON
```

The cursor in the lower left corner of the display indicates that the force set is in progress. The bit will remain ON as long as the Set Key is held down.

4. The output indicator for output IR 01000 will flash ten times if the program is operating correctly. The indicator should go OFF after ten one-second flashes.

There is a mistake in the program if the output indicator doesn't flash. In this case, check the program and force set/reset bits to check operation.

SECTION 8

Test Runs and Error Processing

This section describes procedures for test runs of CPM2B operation, self-diagnosis functions, and error processing to identify and correct the hardware and software errors that can occur during PLC operation.

8-1	Initial System Checks and Test Run Procedure	162
8-1-1	Initial System Checks	162
8-1-2	Flash Memory Precautions	162
8-2	CPM2B Test Run Procedure	163
8-3	Self-diagnostic Functions	163
8-3-1	Identifying Errors	163
8-3-2	User-defined Errors	164
8-3-3	Non-fatal Errors	165
8-3-4	Fatal Errors	165
8-4	Troubleshooting Flowcharts	166
8-5	Maintenance Inspections	174
8-6	Battery Replacement	175

8-1 Initial System Checks and Test Run Procedure

8-1-1 Initial System Checks

Check the following items after setting up and wiring the CPM2B, but before performing a test run.

Item	Points to check
Power supply and I/O connections	Is the wiring correct? Are the terminals securely tightened? Are there any shorts between crimp terminals or wires? Refer to 3-5 <i>Wiring and Connections</i> for details.
Connecting cables	Are the cables all connected correctly and locked? Refer to 3-5 <i>Wiring and Connections</i> for details.

Clearing Memory

Always clear memory before beginning to program the CPM2B. Although memory is cleared before the CPU Board is shipped, the contents of the DM, HR, AR, and counter areas may change in transit.

When a CPU Board without a clock is being used and the contents of DM have been cleared, battery error detection must be disabled in the PLC Setup by setting the leftmost digit of DM 6655 to 1.

Operating Mode at Startup

See 1-3-3 *Operating Mode at Startup* to determine what mode the CPM2B will enter when the power is turned on.

8-1-2 Flash Memory Precautions

Observe the following precautions to protect the flash memory and ensure proper operation.

- 1,2,3...**
1. If changes are made in the read-only DM Area (DM 6144 through DM 6599) or PLC Setup (DM 6600 through DM 6655), the PLC's operating mode must be changed to write the new contents to flash memory. If back-up battery is replaced before the changes are written to flash memory, the changes will be lost.
The changes can be saved by switching the CPM2B to RUN or MONITOR mode or turning the CPM2B OFF and then ON again.
 2. When contents of the program, read-only DM (DM 6144 through DM 6599), or PLC Setup (DM 6600 through DM 6655) have been changed, startup processing will take up to 1,200 ms longer than usual. Be sure to take this one-time startup delay into account if it may affect operations.
 3. If one of the following three operations is performed in MONITOR or RUN mode, the CPM2B's cycle time will be extended by up to 1,200 ms and interrupts will be disabled while the program or PLC Setup is being overwritten.
 - Program changes with the online edit operation
 - Changes to the read-only DM Area (DM 6144 through DM 6599)
 - Changes to the PLC Setup (DM 6600 through DM 6655)

A "SCAN TIME OVER" error won't occur during these operations. Be sure to take this delay in the CPM2B's I/O response times into account when performing online editing.

8-2 CPM2B Test Run Procedure

- 1,2,3...
1. Power Supply Application
 - a) Check the CPM2B's power supply voltage and terminal connections.
 - b) Check the I/O devices' power supply voltage and terminal connections.
 - c) Turn on the power supply and check that the "PWR" indicator lights.
 - d) Use a Programming Device to set the CPM2B to PROGRAM mode.
 2. I/O Wiring Checks
 - a) With the CPM2B in PROGRAM mode, check the output wiring by turning on the output bits with the force set and force reset operations.
 - b) Check the input wiring with the CPM2B's input indicators or a Programming Device's monitor operations.
 3. Test Run
 - a) Use a Programming Device to set the CPM2B to RUN or MONITOR mode and check that the "RUN" indicator lights.
 - b) Check the sequence of operation with the force set/reset operations, etc.
 4. Debugging

Correct any programming errors that are detected.
 5. Saving the Program
 - a) Use a Programming Device to write the program to a backup floppy disk.
 - b) Print out a hard copy of the program with a printer.

Note Refer to *SECTION 7 Using Programming Devices* for details on the Support Software and Programming Console operations.

8-3 Self-diagnostic Functions

The CPM2B is equipped with a variety of self-diagnostic functions to help identify and correct errors and reduce down time.

8-3-1 Identifying Errors

An error can be identified by the error message displayed on a Programming Device, error flags in the AR and SR Areas, and the error code output to SR 253.

Fatal and Non-fatal Errors

PLC errors are divided into 2 categories based on the severity of the errors. The status of the ERR indicator (lit or flashing) shows which type of error has occurred.

ERR Lit (Fatal Error)

Fatal errors are serious errors which stop CPM2B operation. There are two ways to restart operation:

- Turn the PLC OFF and then ON again.
- Use a Programming Device to switch the PLC to PROGRAM mode, and read/clear the error.

ERR Flashing (Non-fatal Error)

Non-fatal errors are less serious errors which don't stop CPM2B operation.

Error Messages	When an error is detected, a corresponding error message will be displayed on the Programming Console or other Programming Device connected to the PLC.
Error Flags	When a hardware error is detected, the corresponding error flag in the AR or SR Area will be turned ON.
Error Code	When an error is detected, a specific 2-digit hexadecimal error code is output to SR 25300 to SR 25307. The error code and time of occurrence are also output to the Error Log Area (DM 2000 to DM 2021).

 **WARNING** When the CPM2B's self-diagnosis function detects a fatal error or when a severe failure alarm (FALS) instruction is executed, PLC operation will stop and all outputs will be turned OFF. External safety measures must be provided to ensure safety in the system. Not providing proper safety measures may result in serious accidents.

8-3-2 User-defined Errors

There are three instructions that can be used to define errors or messages. FAL(06) causes a non-fatal error, FALS(07) causes a fatal error, and MSG(46) sends a message to the Programming Console or host computer connected to the PLC.

FAILURE ALARM – FAL(06)

FAL(06) is an instruction that causes a non-fatal error. The following will occur when an FAL(06) instruction is executed:

- 1,2,3...**
1. The ERR indicator on the CPU Board will flash. PLC operation will continue.
 2. The instruction's 2-digit BCD FAL number (01 to 99) will be written to SR 25300 to SR 25307.

The FAL numbers can be set arbitrarily to indicate particular conditions, but the same number should not be used as both an FAL number and an FALS number.

To clear an FAL error, correct the cause of the error and then execute FAL 00 or use a Programming Device to clear the error.

SEVERE FAILURE ALARM – FALS(07)

FALS(07) is an instruction that causes a fatal error. The following will occur when an FALS(07) instruction is executed:

- 1,2,3...**
1. Program execution will be stopped and all outputs will be turned OFF.
 2. The ERR indicator on the CPU Board will be lit.
 3. The instruction's 2-digit BCD FALS number (01 to 99) will be written to SR 25300 to SR 25307.

The FALS numbers can be set arbitrarily to indicate particular conditions, but the same number should not be used as both an FAL number and an FALS number.

To clear an FALS error, use a Programming Device to switch the PLC to PROGRAM Mode, correct the cause of the error, and then clear the error.

MESSAGE – MSG(46)

MSG(46) is used to display a message on a Programming Device connected to the CPM2B. The message, which can be up to 16 characters long, is displayed when the instruction's execution condition is ON.

8-3-3 Non-fatal Errors

PLC operation and program execution will continue after one or more of these errors have occurred. Although PLC operation will continue, the cause of the error should be corrected and the error cleared as soon as possible.

When one of these errors occurs, the POWER and RUN indicators will remain lit and the ERR indicator will flash.

Message	FAL No.	Meaning and appropriate response
SYS FAIL FAL** (** is 01 to 99 or 9B.)	01 to 99	An FAL(06) instruction has been executed in the program. Check the FAL number to determine conditions that would cause execution, correct the cause, and clear the error.
	9B	An error has been detected in the PLC Setup. Check flags AR 1300 to AR 1302, and correct as directed. AR 1300 ON: An incorrect setting was detected in the PLC Setup (DM 6600 to DM 6614) when power was turned on. Correct the settings in PROGRAM Mode and turn on the power again. AR 1301 ON: An incorrect setting was detected in the PLC Setup (DM 6615 to DM 6644) when switching to RUN or MONITOR mode. Correct the settings in PROGRAM Mode and switch to RUN or MONITOR mode again. AR 1302 ON: An incorrect setting was detected in the PLC Setup (DM 6645 to DM 6655) during operation. Correct the settings and clear the error.
SCAN TIME OVER	F8	The cycle time has exceeded 100 ms. (SR 25309 will be ON.) This indicates that the program cycle time is longer than recommended. Reduce cycle time if possible. (The CPM2B can be set so that this error won't be detected.)
Battery error (no message)	F7	If the voltage of the C500-BAT08 backup battery is below the minimum level, the ERR indicator will flash and SR 25308 will be turned ON. Replace the battery. (See 8-6 Battery Replacement for details.)

8-3-4 Fatal Errors

PLC operation and program execution will stop and all outputs from the PLC will be turned OFF when any of these errors have occurred. CPM2B operation can't be restarted until the PLC is turned off and then on again or a Programming Device is used to switch the PLC to PROGRAM mode and clear the fatal error.

All CPU Board indicators will be OFF for the power interruption error. For all other fatal operating errors, the POWER and ERR indicators will be lit. The RUN indicator will be OFF.

Message	FALS No.	Meaning and appropriate response
Power interruption (no message)	00	Power has been interrupted for more than 2 ms. Check power supply voltage and power lines. Try to power-up again.
MEMORY ERR	F1	AR 1308 ON: There is a non-existent bit or word address in the user program. Check the program and correct errors.
		AR 1309 ON: An error has occurred in flash memory. Replace the CPU Board.
		AR 1310 ON: A checksum error has occurred in read-only DM (DM 6144 to DM 6599). Check and correct the settings in the read-only DM Area.
		AR 1311 ON: A checksum error has occurred in the PLC Setup. Initialize the PLC Setup and input the settings again.
		AR 1312 ON: A checksum error has occurred in the program. Check the program and correct any errors detected.
		AR 1313 ON: A checksum error has occurred in the expansion instructions data and all function codes have been set the their default values. Reset the expansion instructions.
		AR 1314 ON: Data was not maintained in an area specified for holding. Clear the error, check the data in the areas specified for holding, and try again.
NO END INST	F0	END(01) is not written in the program. Write END(01) at the end of the program.

Message	FALS No.	Meaning and appropriate response
I/O BUS ERR	C0	An error has occurred during data transfer between the CPU Board and an Expansion I/O Board. Check the Board's connecting cable.
I/O UNIT OVER	E1	Too many Expansion I/O Boards have been connected. Check the Board configuration.
SYS FAIL FALS** (** is 01 to 99 or 9F.)	01 to 99	A FALS(07) instruction has been executed in the program. Check the FALS number to determine the conditions that caused execution, correct the cause, and clear the error.
	9F	The cycle time has exceeded the Maximum (Watch) Cycle Time setting (DM 6618). Check the cycle time and adjust the Maximum Cycle Time setting if necessary.

8-4 Troubleshooting Flowcharts

Use the following flowcharts to troubleshoot errors that occur during operation.

Main Check

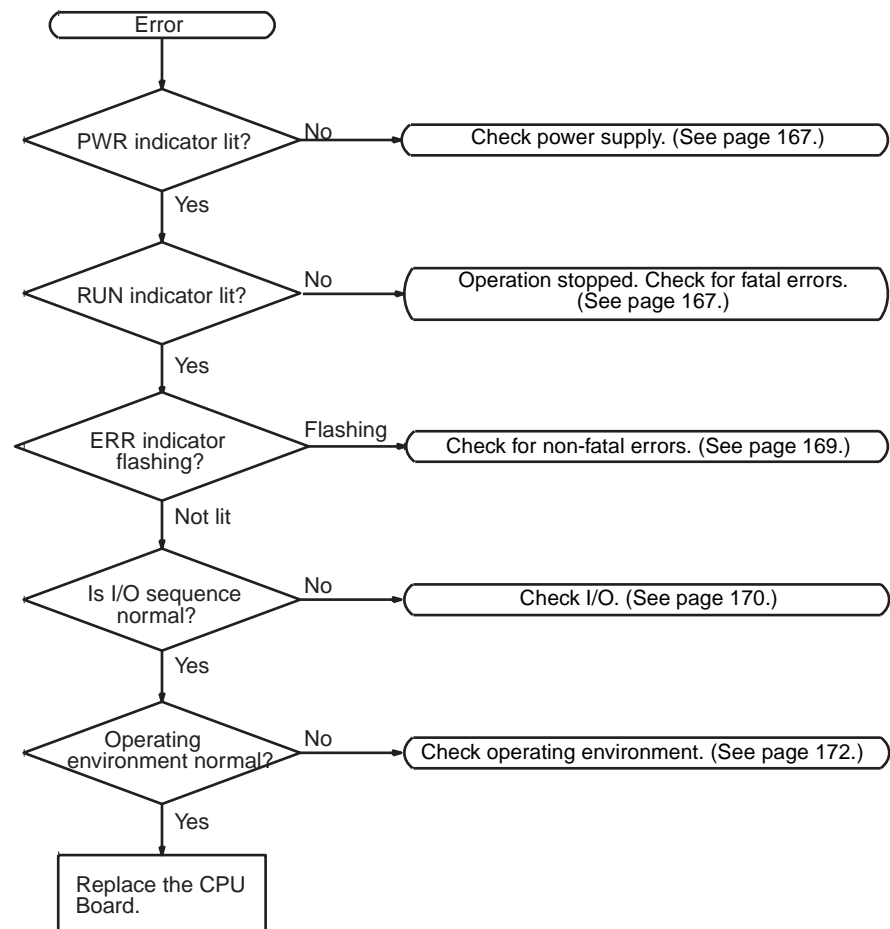

Power Supply Check

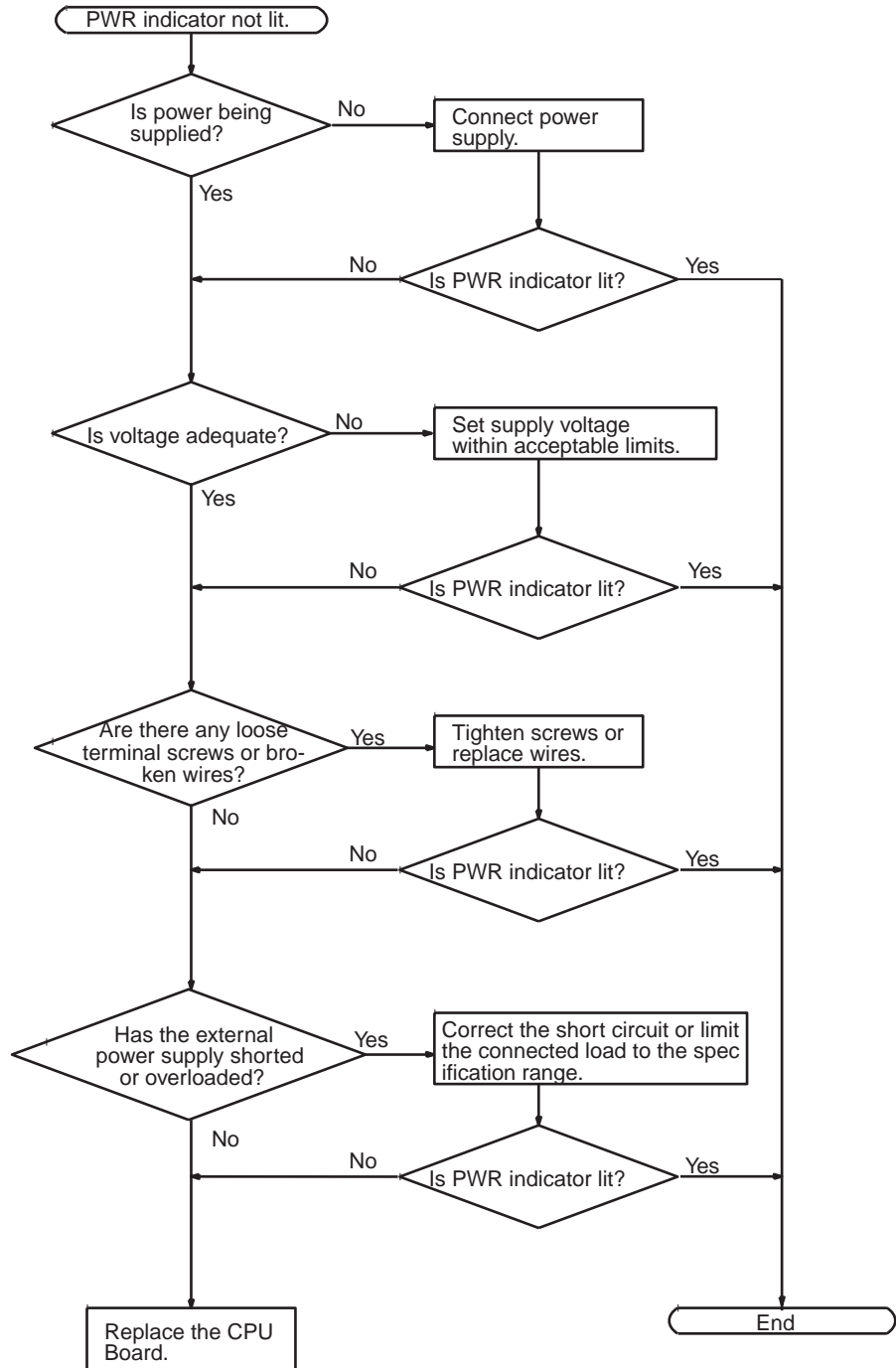

Fatal Error Check

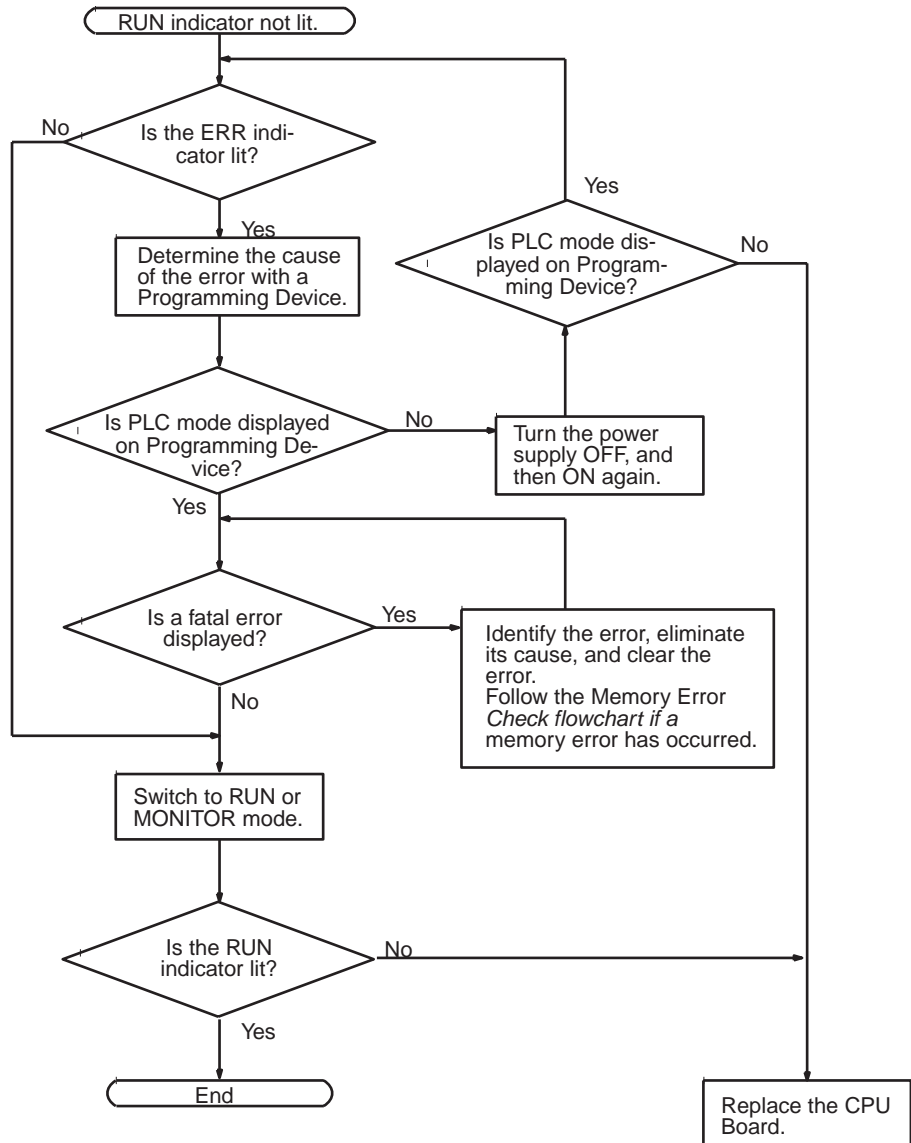

Non-fatal Error Check

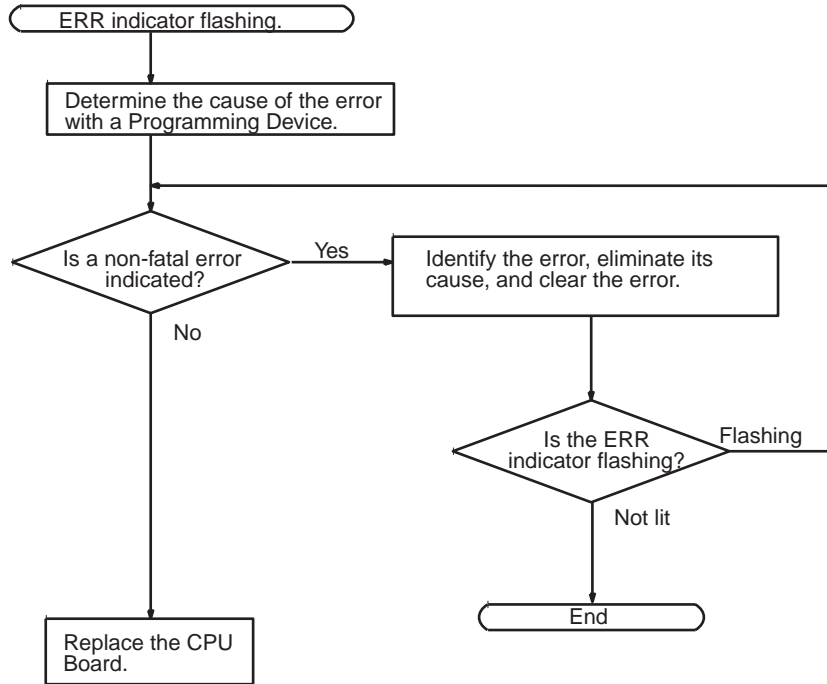

I/O Check

The I/O check flowchart is based on the following ladder diagram section.

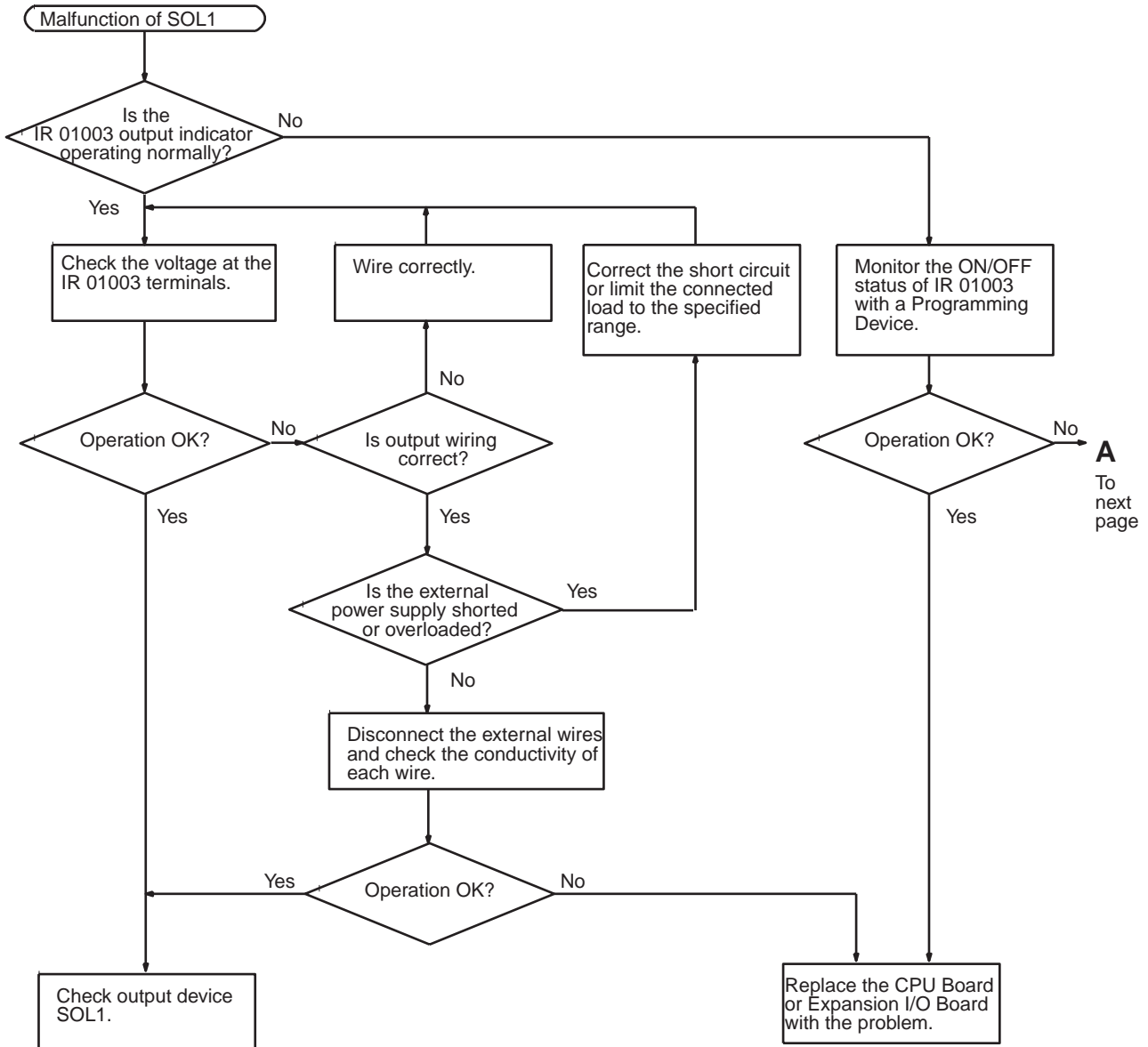
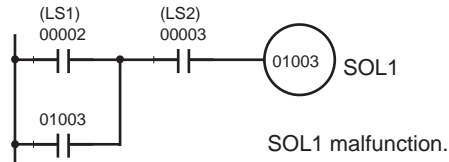

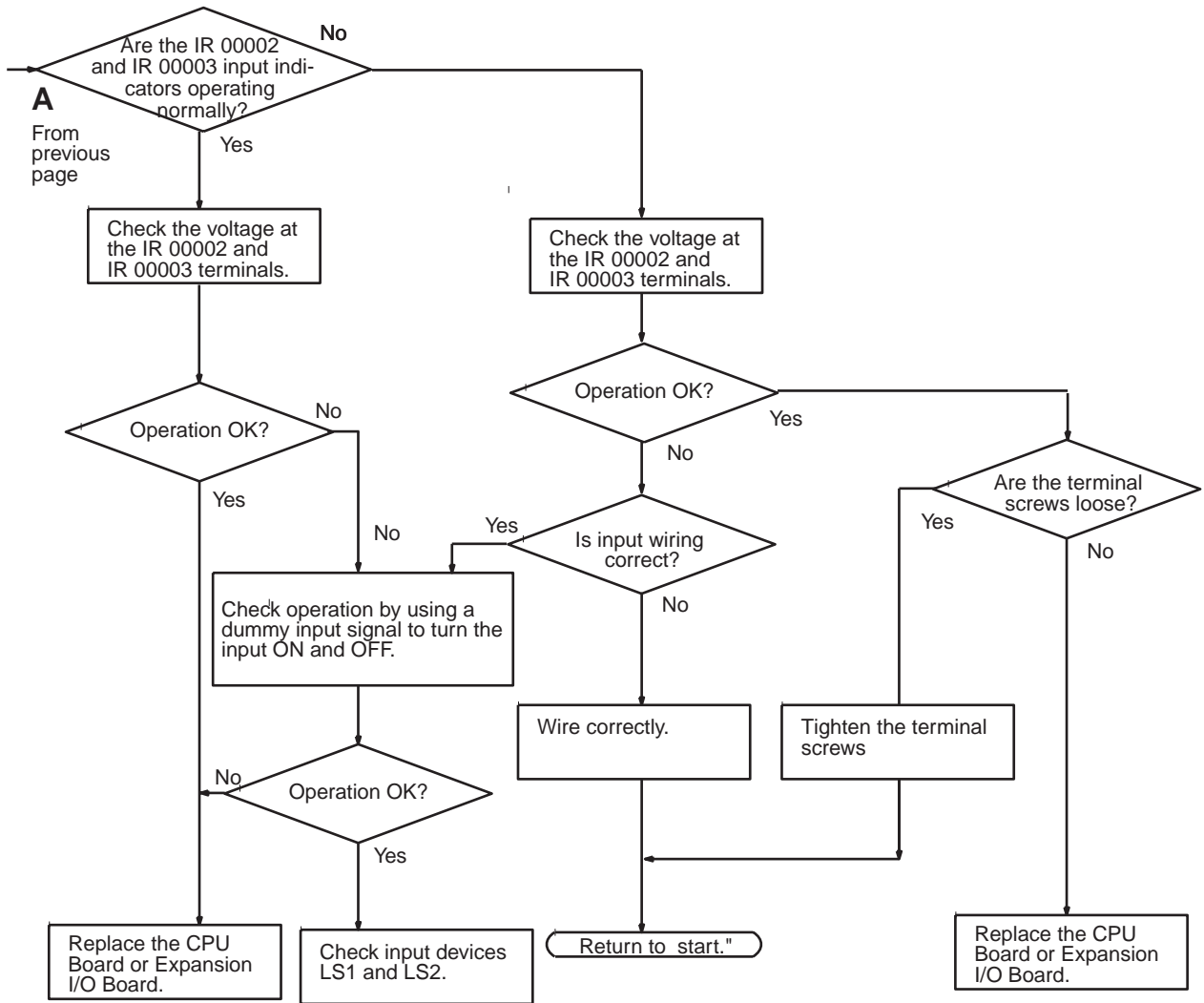

Environmental Conditions Check

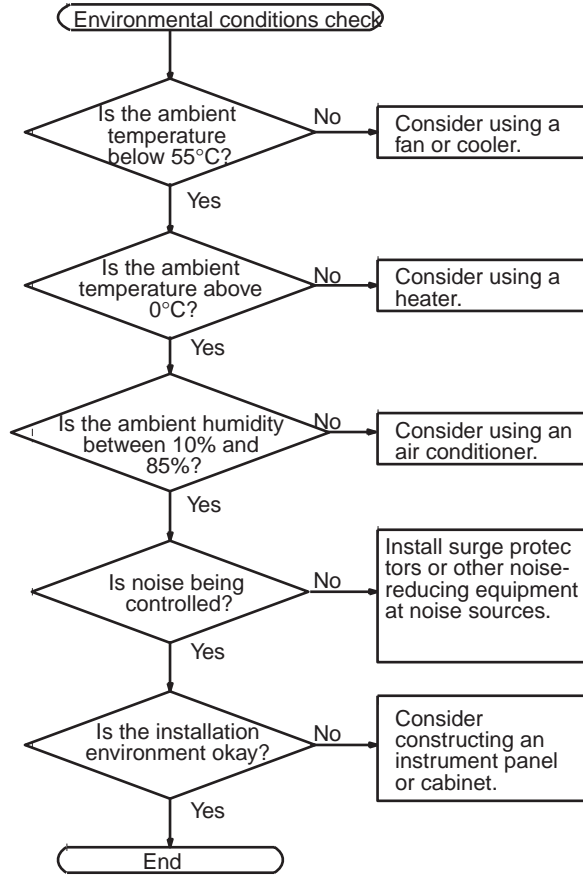

Memory Error Check

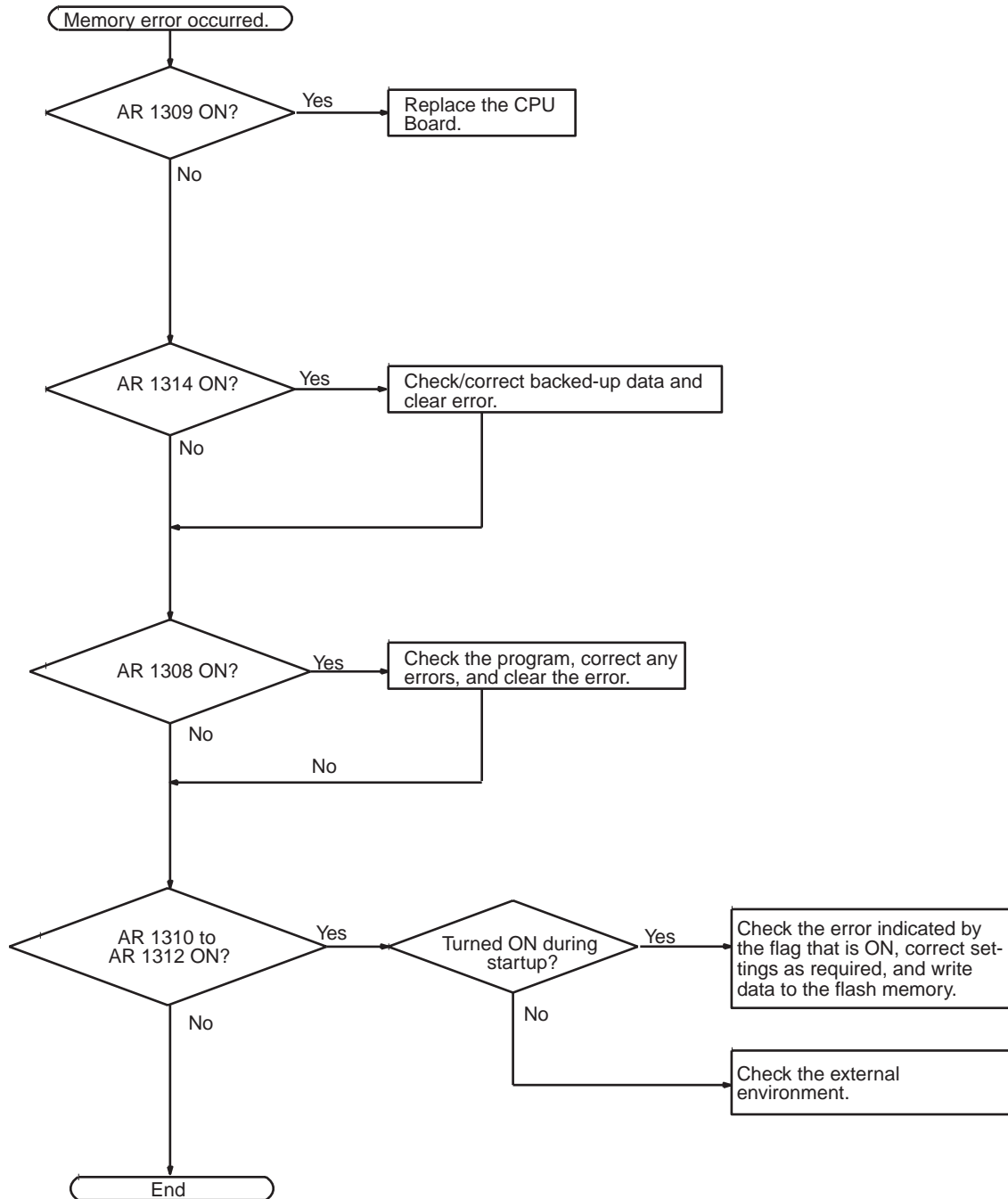

8-5 Maintenance Inspections

In order for your SYSMAC system to operate in optimum condition, be sure to carry out daily or periodical inspections.

Inspection Items

The main system components of a SYSMAC system are semiconductors, and it contains few components with limited lifetimes. Poor environmental conditions, however, can lead to deterioration of the electrical components, making regular maintenance necessary.

The standard period for maintenance checks is 6 months to 1 year, but more frequent checks are required if the PLC is operated in more demanding conditions.

If the criteria are not met, adjust to within the specified ranges.

Inspection items	Details	Criteria	Remarks
Power supply	Determine whether the voltage fluctuation at the power supply terminals is within specifications.	Within the voltage variation range: 24-V DC model: 20.4 to 26.4 V DC 12-V DC model: 10.8 to 14.4 V DC	Tester
Environmental conditions	Is the ambient temperature inside the panel appropriate?	0 to 55°C	Thermometer
	Is the ambient humidity inside the panel appropriate?	35% to 85% RH with no condensation	Hygrometer
	Has dirt or dust collected?	None	Visual inspection
I/O power supply	Is the voltage fluctuation measured at the I/O terminals within the standard range?	Each I/O terminal must conform to the specifications	Tester
Installation status	Are all Boards securely installed?	Nothing is loose	Phillips screwdriver
	Are all connection cables and connectors inserted completely and locked?	Nothing is loose	Visual inspection
	Are any of the external wiring screws loose?	Nothing is loose	Phillips screwdriver
	Are any of the external wiring cables frayed?	No external abnormalities	Visual inspection
Product service life	Contact output relay	Electrical: Resistance load: 300,000 operations Inductive load: 100,000 operations Mechanical: 10,000,000 operations	---
	Battery (C500-BAT08)	5 years	---

Required Tools

Standard Tools (Required)

- Screwdrivers (Phillips and flat-blade)
- Voltage tester or digital voltage meter
- Industrial alcohol and a cotton cloth

Measurement Devices (May be Needed)

- Synchroscope
- Cathode-ray oscilloscope
- Thermometer, hygrometer

Note Do not attempt to disassemble, repair, or modify the PLC in any way.

8-6 Battery Replacement

 **WARNING** Do not drop, disassemble, crush, short-circuit, recharge, or dispose of the battery in fire. The battery may explode, burn, or leak and cause personal injury.

Precautions

Turn ON the power supply for at least 5 minutes before replacing the battery in order to recharge the backup capacitor.

Turn OFF the power supply to the CPU Board before replacing the battery.

Use the procedure below when replacing the battery. This procedure must be completed within 5 minutes to prevent loss of memory contents.

Dispose of the old battery properly.

Replacement Procedure

CPU Boards that are equipped with a clock are also equipped with a backup battery that has a 5-year lifetime at 25°C. Use the following procedure when replacing the backup battery.

- 1,2,3...
1. Stop CPM2B operation and turn OFF the CPM2B's power supply.
 2. Disconnect the battery connector and remove the battery.

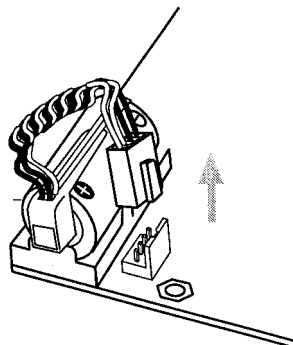

3. Install the new battery. Check the alignment of the connector and fully insert the connector. Make sure that the power wires are not pinched.

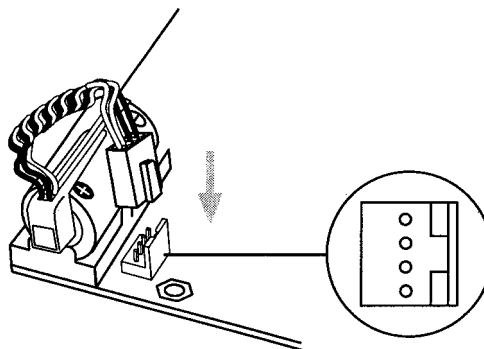



4. Enable the detection of battery errors in the PLC Setup by setting the left-most digit of DM 6655 to 0.

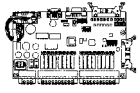
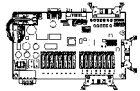

Appendix A

Standard Models

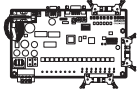
CPU Boards

Appearance	Power supply	Input	Output	Connection with external I/O device	Internal clock, RS-232C port, and battery	Model
	24 V DC	16 points (24 V DC)	16 relay outputs	Transistor Block	No	CPM2B-32C1DR-D
					Yes	CPM2B-32C2DR-D
	24 V DC		16 sinking transistor outputs	Connector	No	CPM2B-32C1DT-D
					Yes	CPM2B-32C2DT-D
	24 V DC	24 points (24 VDC)	16 relay outputs	Connector	Yes	CPM2B-40C2DR-D
	12 V DC	16 points (12 V DC)	16 relay outputs	Connector	No	CPM2B-32C1DT1-D12
					Yes	CPM2B-32C2DT1-D12

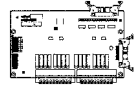
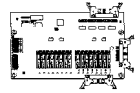
Expansion I/O Boards

Appearance	Input	Output	Connection with external I/O device	Model
	16 points (24 V DC)	16 relay outputs	Transistor Block	CPM2B-32EDR
	16 points (24 V DC)	16 sinking transistor outputs	Connector	CPM2B-32EDT
	16 points (12 V DC)			CPM2B-32ED1T
	24 points (24 V DC)	16 relay outputs	Transistor Block	CPM2B-40EDR
	32 points (24 V DC)	32 sinking transistor outputs	Connector	CPM2B-64EDT

Analog I/O Boards

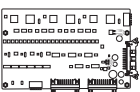
Appearance	Analog input		Analog output		Model
	Input signal range	Number of inputs	Output signal range	Number of outputs	
	0 to 5 V, 1 to 5 V, 0 to 10 V, -10 to 10 V, 0 to 20 mA, and 4 to 20 mA	2 points	1 to 5 V, 0 to 10 V, -10 to 10 V, 0 to 20 mA, and 4 to 20 mA	1 point	CPM2B-MAD21
		4 points		2 points	CPM2B-MAD42
		6 points		3 points	CPM2B-MAD63

Note The Analog I/O Board can be connected to a 24-V DC CPU Board. The 12-V DC CPU Boards cannot be used.



Expansion I/O Cable

Appearance	Model	Specifications
	CPM2B-CN601	Connects an Expansion I/O Board to the CPU Board or another Expansion I/O Board. (This cable is identical to the cable supplied with an Expansion I/O Board. Cable length: 60 mm.)

Mounting Bracket

Appearance	Model	Specifications
	CPM2B-ATT01	Includes four M3 × 4 mounting screws. Note The CPM2B-ATT01 Mounting Bracket is required when the system must meet UL/CSA standards.

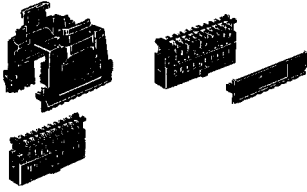

I/O Connectors

Appearance	Name	32-point CPU Boards and Expansion I/O Boards	40-point CPU Boards and Expansion I/O Boards	64-point Expansion I/O Boards	
	Socket	AWG 24	XG5M-2032-N	XG5M-3432-N	XG5M-4032-N
		AWG 26 to 28	XG5M-2035-N	XG5M-3435-N	XG5M-4035-N
	Full Cover (2 required for each Socket)		XG5S-2012	XG5S-3412	XG5S-4012
	Partial Cover (2 required for each Socket)		XG5S-1001	XG5S-1701	XG5S-2001
	Socket		XG4M-2030	XG4M-3430	XG4M-4030
	Strain Relief		XG4T-2004	XG4T-3404	XG4T-4004
	Set (Socket + Strain Relief)		XG4M-2030-T	XG4M-3430-T	XG4M-4030-T
	Recommended Flat Cable		XG4T-200□	Not available	Not available

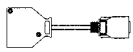
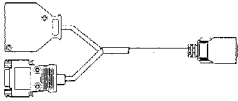
Communications Port Connecting Cables

Appearance	Name	Specifications	Length
	CS1W-CN114 Connecting Cable	Peripheral port to Programming Console cable.	0.05 m
	CPM2C-CN111 Connecting Cable	Peripheral port to Programming Console cable.	0.1 m

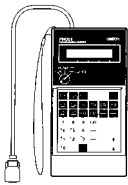
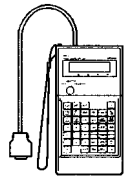
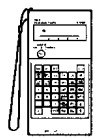

Peripheral Devices

Appearance	Model Number	Name	Specifications	
	CQM1H-PRO01-E	Programming Console	2-m Connecting Cable attached	
	CQM1-PRO01-E	Programming Console	2-m Connecting Cable attached Requires a CS1W-CN114 or CPM2C-CN111 Connecting Cable.	
	C200H-PRO27-E		Hand-held, w/backlight; requires a C200H-CN222 or C200H-CN422 Connecting Cable, see below.	
	C200H-CN222		Connects the C200H-PRO27-E.	2-m cable
	C200H-CN422			4-m cable
	CS1W-CN224		Connects the C200H-PRO27-E directly to a CPM2B CPU Board.	2-m cable
CS1W-CN624		6-m cable		
	WS02-CXPC1-E	CX-Programmer	For MS-Windows 95/98/NT (CD-ROM)	

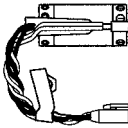
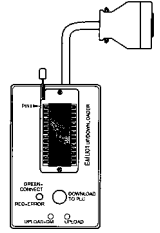
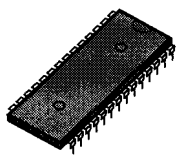

Maintenance Accessories

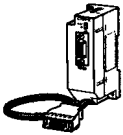
Appearance	Model Number	Name	Specifications
	C500-BAT08	Backup Battery	---
	CPM1-EMU01-V1	Expansion Memory Unit	Uploads the ladder program and DM 6144 to DM 6655 from the PLC to the EEPROM and downloads the ladder program and DM 6144 to DM 6655 from the EEPROM to the PLC.
	EEROM-JD	EEPROM	256 K bit

Adapters and Connecting Cables (1:1 Connection)

CPM2B port	Appearance	Model number	Name	Comments	Cable length
Peripheral		CQM1-CIF02	RS-232C Adapter	For a 9-pin computer serial port	3.3 m
		CPM1-CIF01		Use for peripheral port to RS-232C level conversion	
RS-232C		XW2Z-200S-V	RS-232C Cable	For a 9-pin computer serial port	2 m
		XW2Z-500S-V			5 m

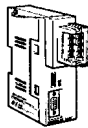
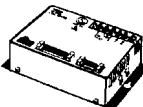
Adapters and Connecting Cables (1:N Connections)

Appearance	Model number	Name	Specifications	
	NT-AL001-E	RS-422 Adapter	Use for CPM2B RS-232C port to RS-422A conversion. Requires a 5-VDC, 150 mA power supply which is supplied through the CPM2B connection. (Can also be connected to a personal computer, but this connection requires an external 5-VDC power supply.)	
	3G2A9-AL004-E	Link Adapter	Use for personal computer RS-232C port to RS-422A. (Can also be connected to a CPM2B.)	
	CPM1-CIF11	RS-422 Adapter	Use for CPM2B peripheral port to RS-422A conversion.	The CS1W-CN114 is required to connect to the CPM2B.
	CQM1H-CIF12			Can be connected directly to the CPM2B.
	XW2Z-070T-1	RS-232C Cables (For use with the NT-AL001-E.)	Use for CPM2B RS-232C port to NT-AL001-E connection. (0.7-m cable)	
	XW2Z-200T-1		Use for CPM2B RS-232C port to NT-AL001-E connection. (2-m cable)	

Appendix B

Dimensions

All dimensions are in millimeters.

CPU Boards

32-point Models (CPM2B-32C□D□-D)

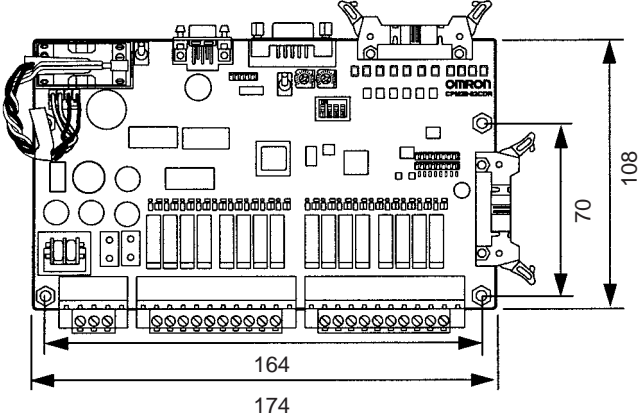

40-point Models (CPM2B-40C2DR-D)

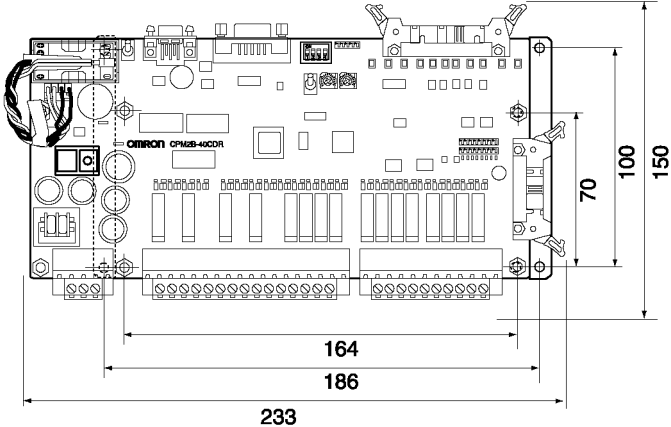

Expansion I/O Boards

32-point Models (CPM2B-32ED□)

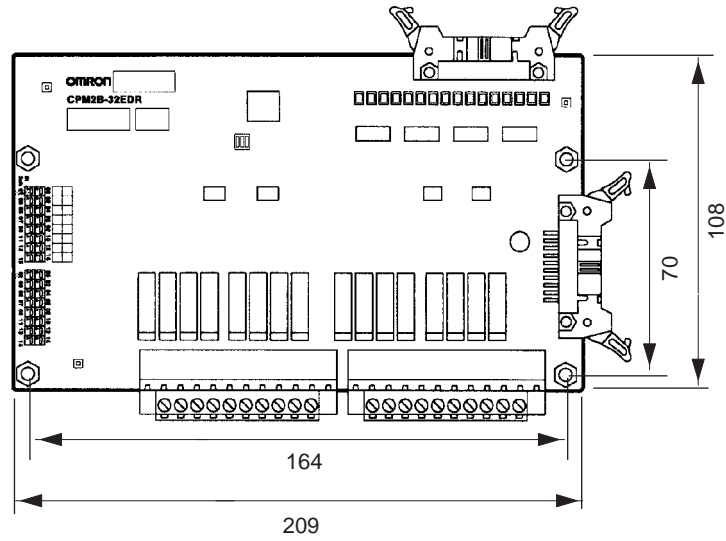

40-point Models (CPM2B-40EDR)

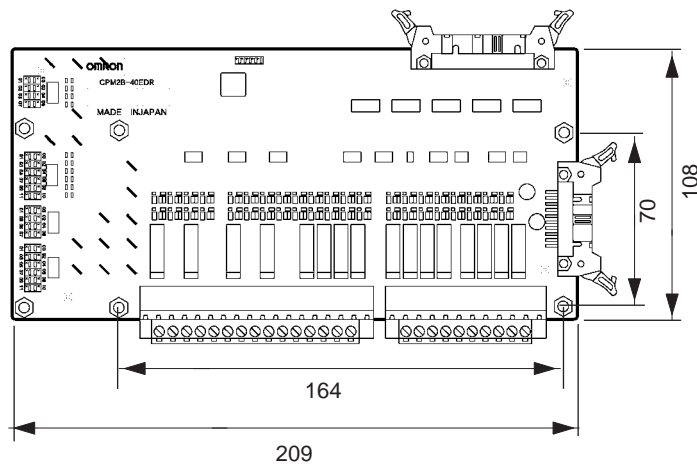

64-point Models (CPM2B-64EDT)

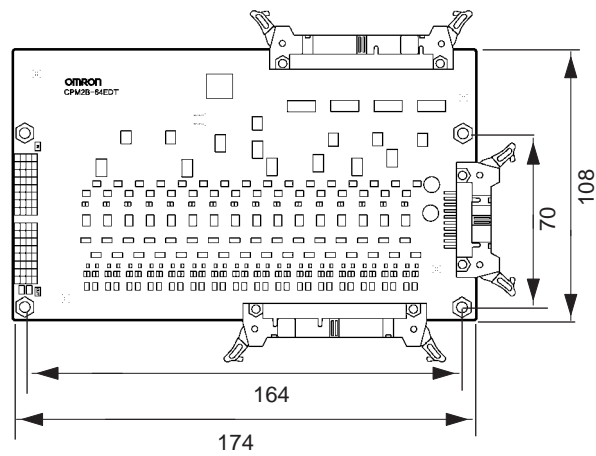

Analog I/O Board (CPM2B-MAD□□)

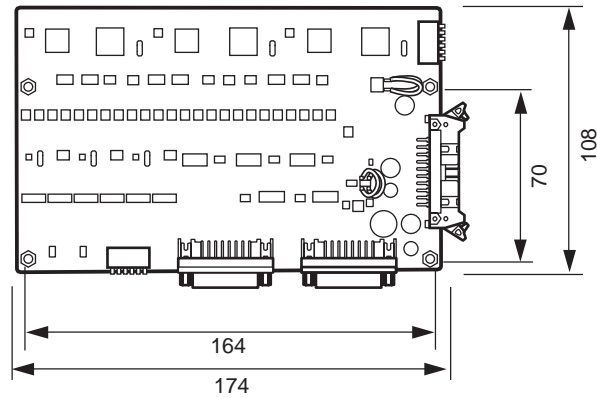

Mounting Bracket (CPM2B-ATT01)

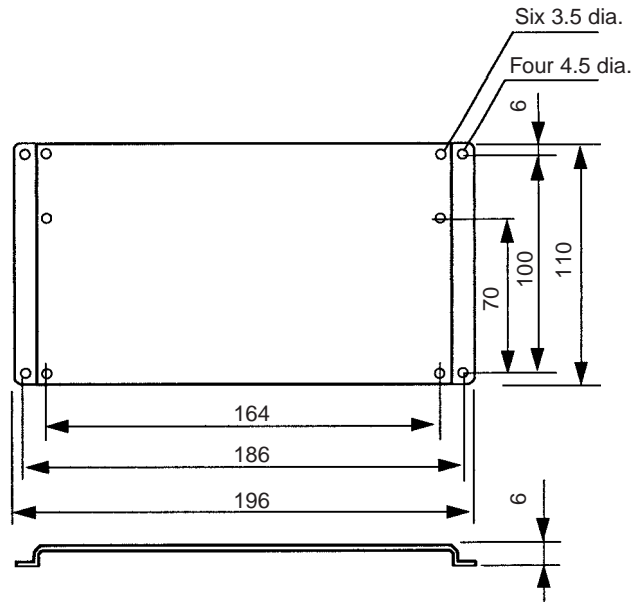

Weight

Name		Model	Weight
CPU Board	24 V DC	CPM2B-32C1DR-D	233 g max.
		CPM2B-32C2DR-D	260 g max.
		CPM2B-32C1DT-D	150 g max.
		CPM2B-32C2DT-D	178 g max.
		CPM2B-40C2DR-D	294 g max.
	12 V DC	CPM2B-32C1DT1-D12	150 g max.
CPM2B-32C2DT1-D12		178 g max.	
Expansion I/O Board		CPM2B-32EDR	199 g max.
		CPM2B-32EDT/32ED1T	115 g max.
		CPM2B-40EDR	239 g max.
		CPM2B-64EDT	166 g max.
Analog I/O Board		CPM2B-MAD□□	160 g max.

Assembly Dimensions

Front view
32-point CPU Board or Expansion I/O Board

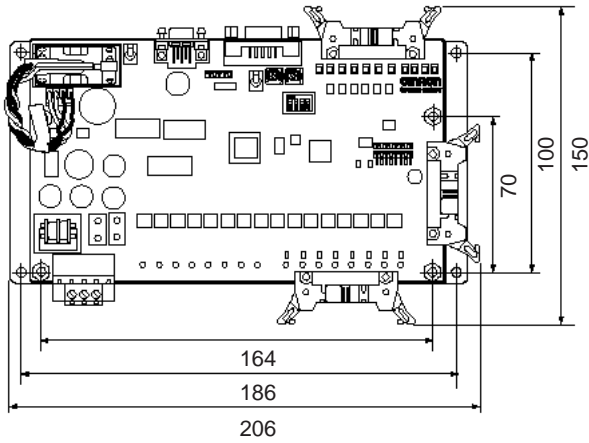

Side view

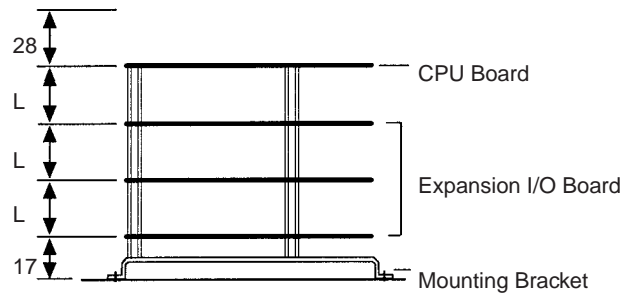

Boards		L
32-point models	Expansion I/O Board (24 V DC)	26 mm
32-point models	Expansion I/O Board (12 V DC)	22 mm
40/60-point models	Expansion I/O Board (24 V DC)	

40-point CPU Board or Expansion I/O Board

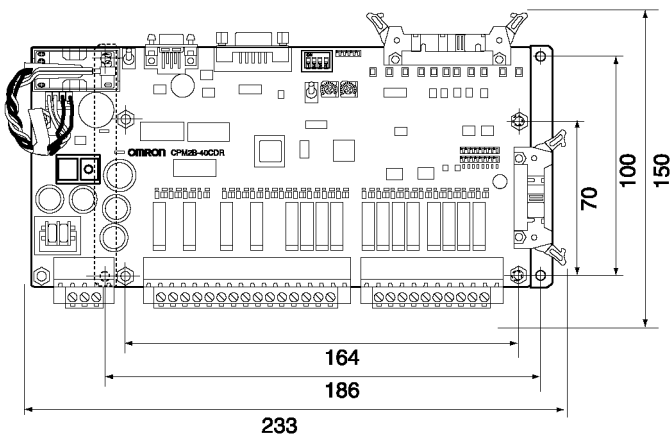

Appendix C

Connections Diagrams for Connector Terminal Blocks and Relay Terminals

1. Connecting Inputs of 32-point Board to G7TC-ID16 Relay Terminal

CN1		CN2	
Contact No.	Pin No.	Pin No.	I/O symbol
COM	1	3,4	24V
00	3	13	11
01	5	15	10
02	7	17	9
03	9	19	8
04	4	5	15
05	6	7	14
06	8	9	13
07	10	11	12
COM	11	3,4	24V
08	13	14	3
09	15	16	2
10	17	18	1
11	19	20	0
12	14	6	7
13	16	8	6
14	18	10	5
15	20	12	4
NC *	2	3,4	24V
NC *	12	3,4	24V

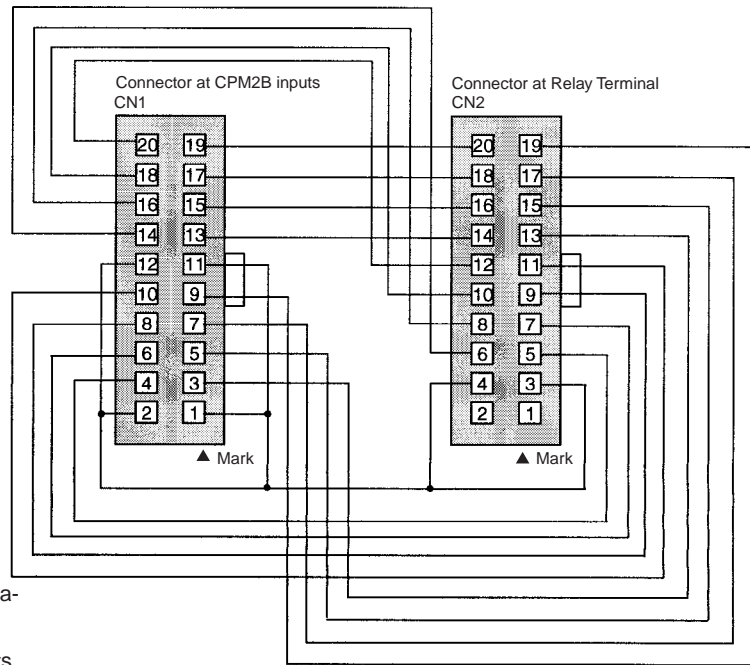

* These contacts are connected in this diagram to illustrate the correspondence with the cable in 5 below. Normally, it is not necessary to connect these contacts.

2. Connecting Inputs of 32-point Board to XW2B-20Y4 or XW2B-20Y5 Connector Terminal Conversion Unit

CN1		CN2	
Contact No.	Pin No.	Pin No.	I/O symbol
COM	1	1	1
00	3	3	3
01	5	5	5
02	7	7	7
03	9	9	9
04	4	4	4
05	6	6	6
06	8	8	8
07	10	10	10
COM	11	11	11
08	13	13	13
09	15	15	15
10	17	17	17
11	19	19	19
12	14	14	14
13	16	16	16
14	18	18	18
15	20	20	20
NC *	2	2	2
NC *	12	12	12

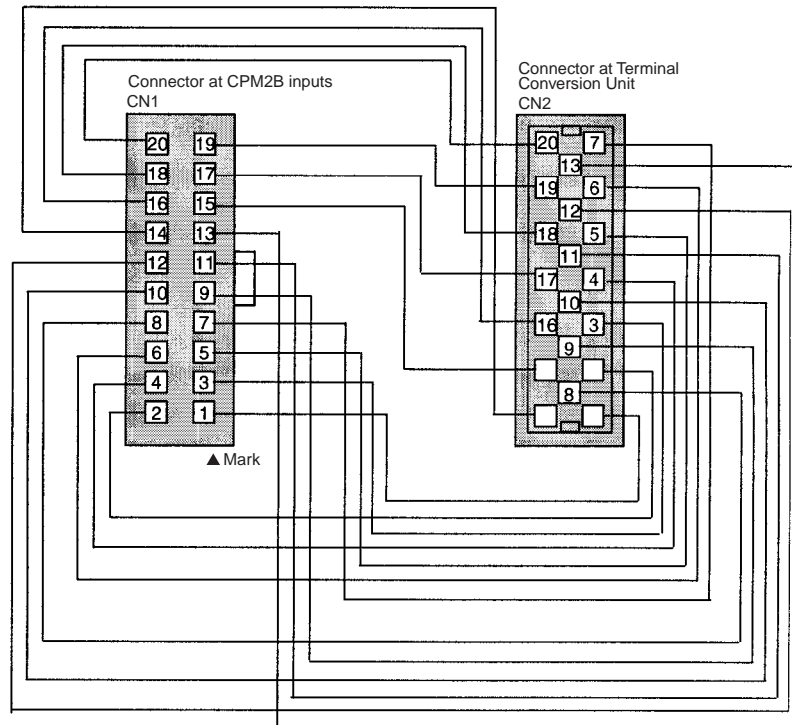

* These contacts are connected in this diagram to illustrate the correspondence with the cable in 6 below. Normally, it is not necessary to connect these contacts.

3. Connecting Inputs of 32-point Board to XW2B-20G4, XW2B-20G5, or XW2B-20G5-D Connector Terminal Conversion Unit

CN1		CN2	
Contact No.	Pin No.	Pin No.	I/O symbol
COM	1	1	1
00	3	3	3
01	5	5	5
02	7	7	7
03	9	9	9
04	4	4	4
05	6	6	6
06	8	8	8
07	10	10	10
COM	11	11	11
08	13	13	13
09	15	15	15
10	17	17	17
11	19	19	19
12	14	14	14
13	16	16	16
14	18	18	18
15	20	20	20
NC *	2	2	2
NC *	12	12	12

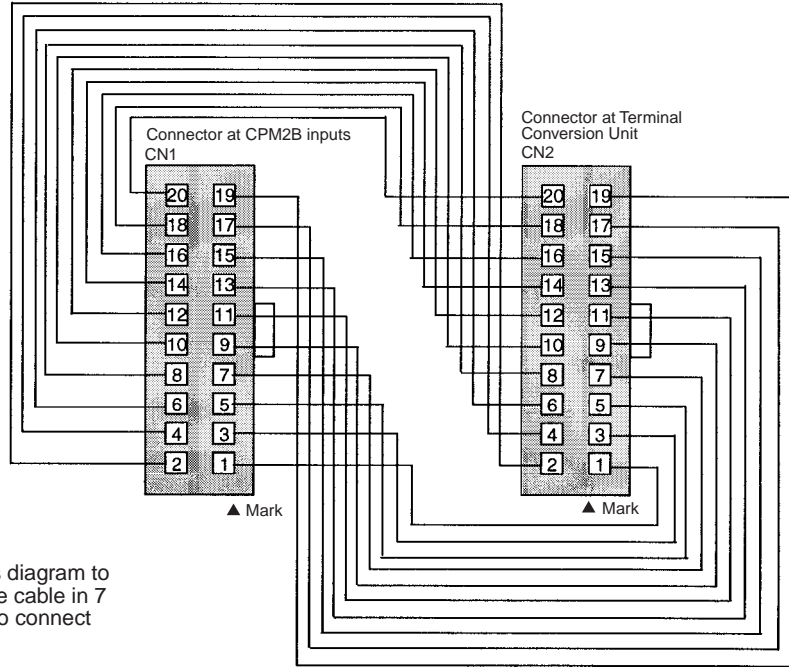

* These contacts are connected in this diagram to illustrate the correspondence with the cable in 7 below. Normally, it is not necessary to connect these contacts.

4. Connecting Inputs of 32-point Board to XW2C-20G5-IN16 Connector Terminal Conversion Unit

CN1		CN2	
Contact No.	Pin No.	Pin No.	I/O symbol
COM	1	17	2,3,7,11,15,19,23,27,31
00	3	1	4
01	5	3	6
02	7	5	8
03	9	7	10
04	4	9	12
05	6	11	14
06	8	13	16
07	10	15	18
COM	11	18	2,3,7,11,15,19,23,27,31
08	13	2	20
09	15	4	22
10	17	6	24
11	19	8	26
12	14	10	28
13	16	12	30
14	18	14	32
15	20	16	34
NC	2	Not connected	Not connected
NC	12	Not connected	Not connected
Not connected	Not connected	19	NC
Not connected	Not connected	20	NC

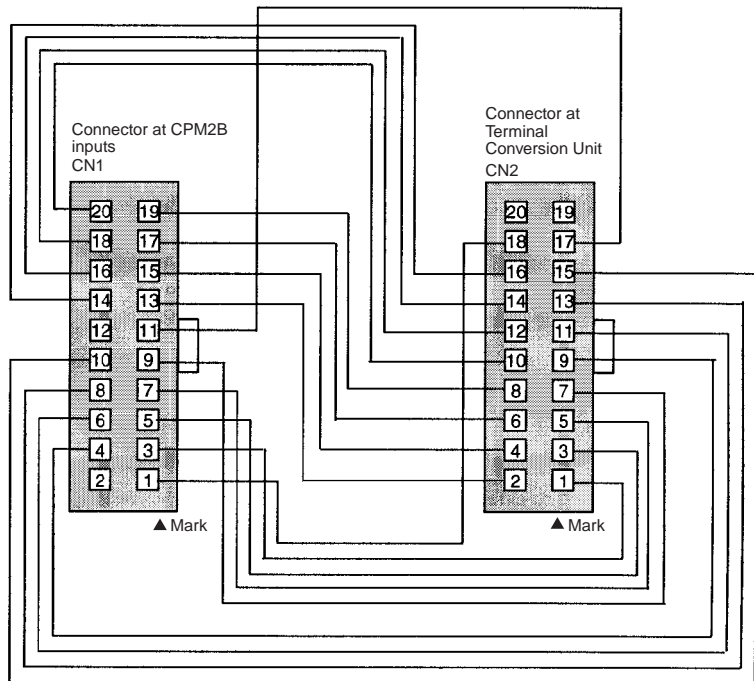

5. Connecting Outputs of 32-point Board to G70D-SOC16, G70D-FOM16, G7TC-OC16, or G70A-ZOC16-3 Relay Terminal

CN1		CN2	
Contact No.	Pin No.	Pin No.	I/O symbol
00	19	20	A0
01	17	18	A1
02	15	16	A2
03	13	14	A3
COM	11	3,4	0V
04	20	12	A4
05	18	10	A5
06	16	8	A6
07	14	6	A7
COM	12	3,4	0V
08	9	19	A8
09	7	17	A9
10	5	15	A10
11	3	13	A11
COM	1	3,4	0V
12	10	11	A12
13	8	9	A13
14	6	7	A14
15	4	5	A15
COM	2	3,4	0V

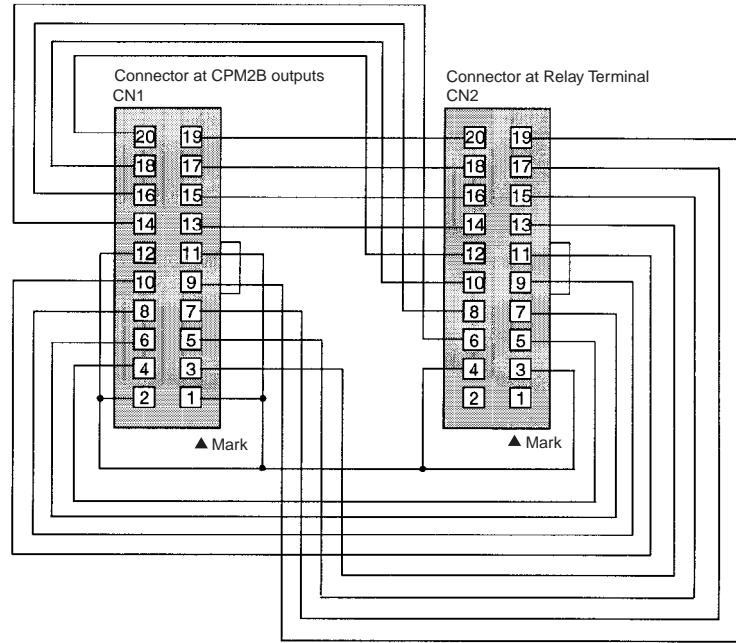

6. Connecting Outputs of 32-point Board to XW2B-20Y4 or XW2B-20Y5 Connector Terminal Conversion Unit

CN1		CN2	
Contact No.	Pin No.	Pin No.	I/O symbol
00	19	19	19
01	17	17	17
02	15	15	15
03	13	13	13
COM	11	11	11
04	20	20	20
05	18	18	18
06	16	16	16
07	14	14	14
COM	12	12	12
08	9	9	9
09	7	7	7
10	5	5	5
11	3	3	3
COM	1	1	1
12	10	10	10
13	8	8	8
14	6	6	6
15	4	4	4
COM	2	2	2

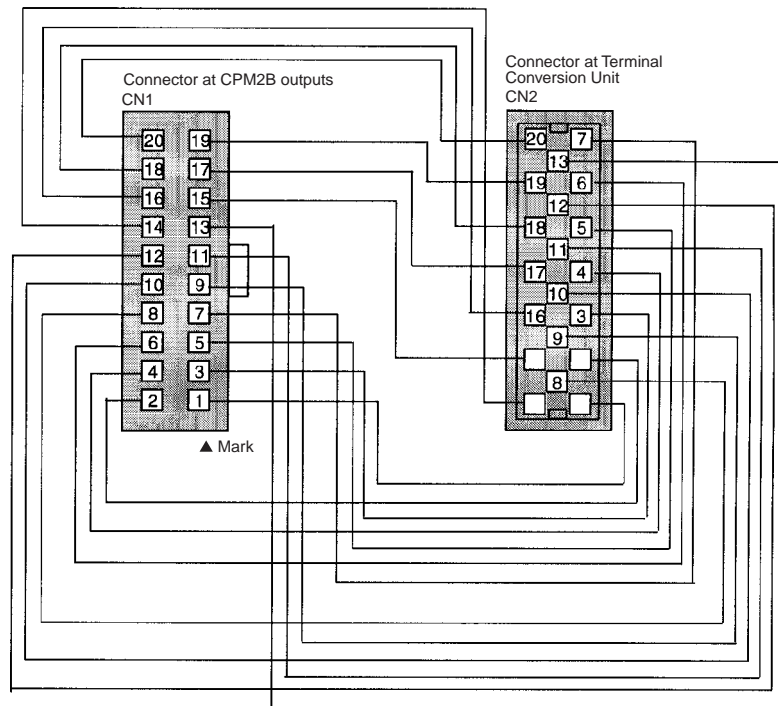

7. Connecting Outputs of 32-point Board to XW2B-20G4, XW2B-20G5, or XW2B-20G5-D Connector Terminal Conversion Unit

CN1		CN2	
Connector at CPM2B outputs: XG5M-2032-N, XG5M-2035-N		Connector at Terminal Conversion Unit: XG5M-2032-N, XG5M-2035-N	
Contact No.	Pin No.	Pin No.	I/O symbol
00	19	19	19
01	17	17	17
02	15	15	15
03	13	13	13
COM	11	11	11
04	20	20	20
05	18	18	18
06	16	16	16
07	14	14	14
COM	12	12	12
08	9	9	9
09	7	7	7
10	5	5	5
11	3	3	3
COM	1	1	1
12	10	10	10
13	8	8	8
14	6	6	6
15	4	4	4
COM	2	2	2

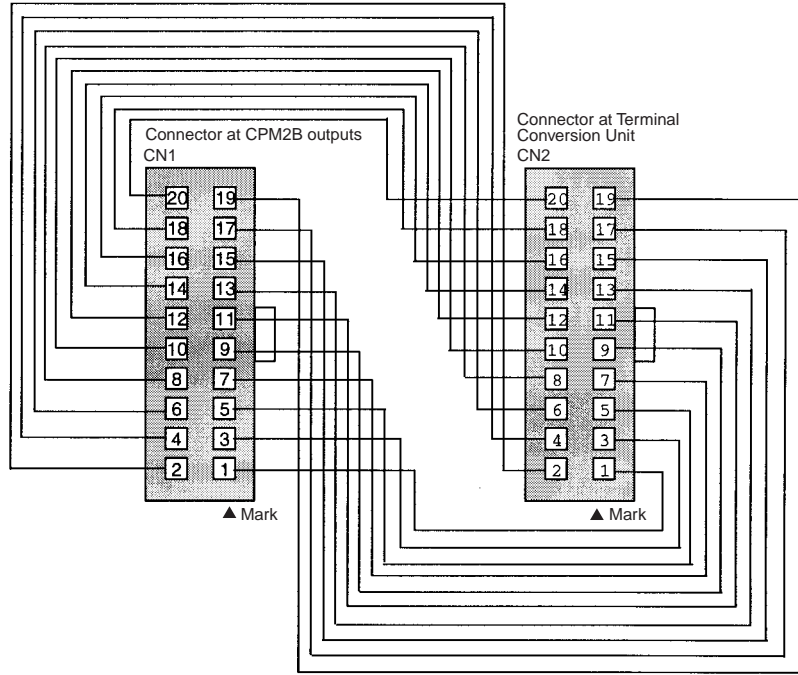

8. Connecting Inputs of 64-point Board to XW2B-20G4, XW2B-20G5, or XW2B-20G5-D Connector Terminal Conversion Unit

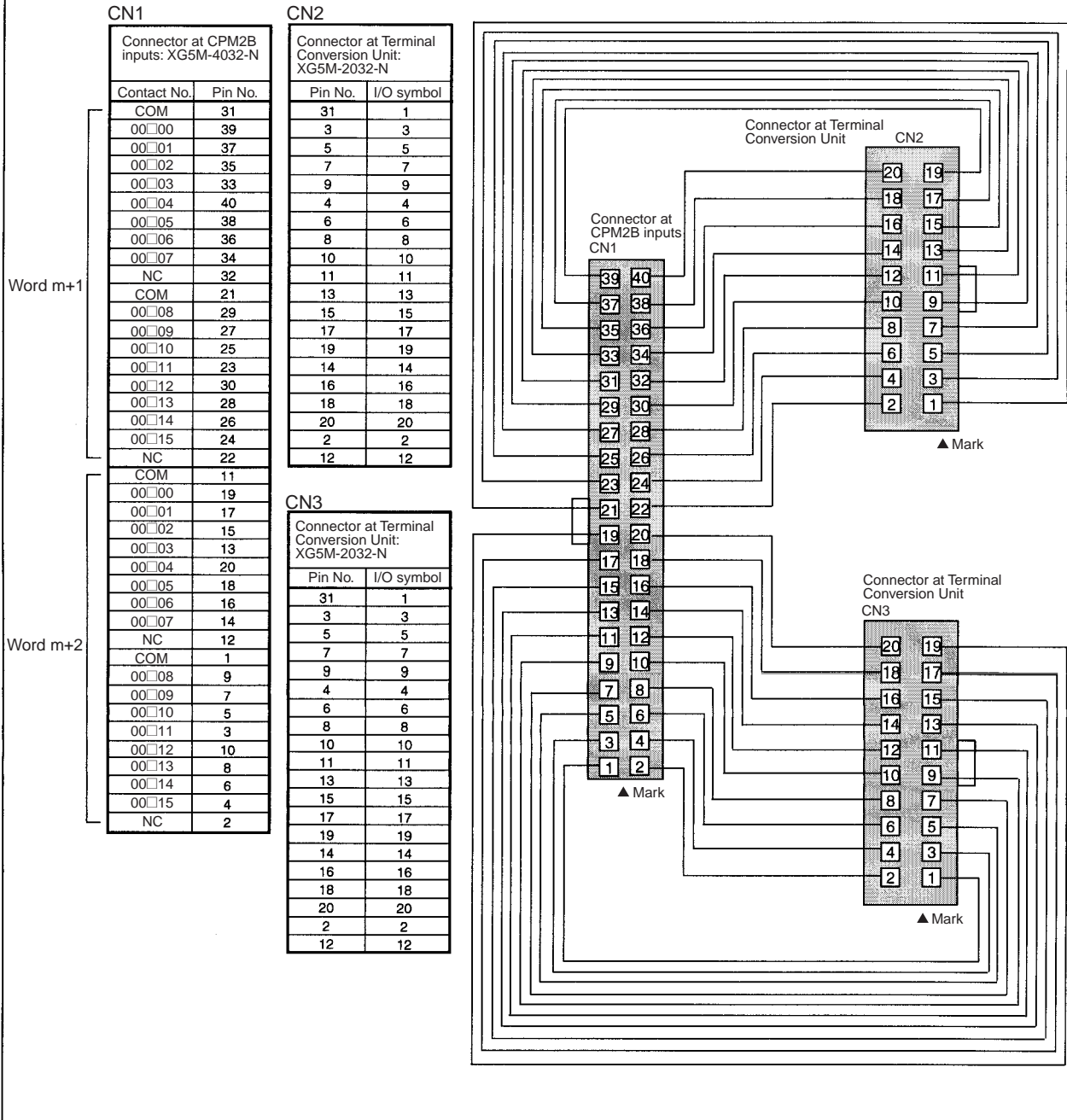

9. Connecting Outputs of 64-point Board to 70D-SOC16 Relay Terminal

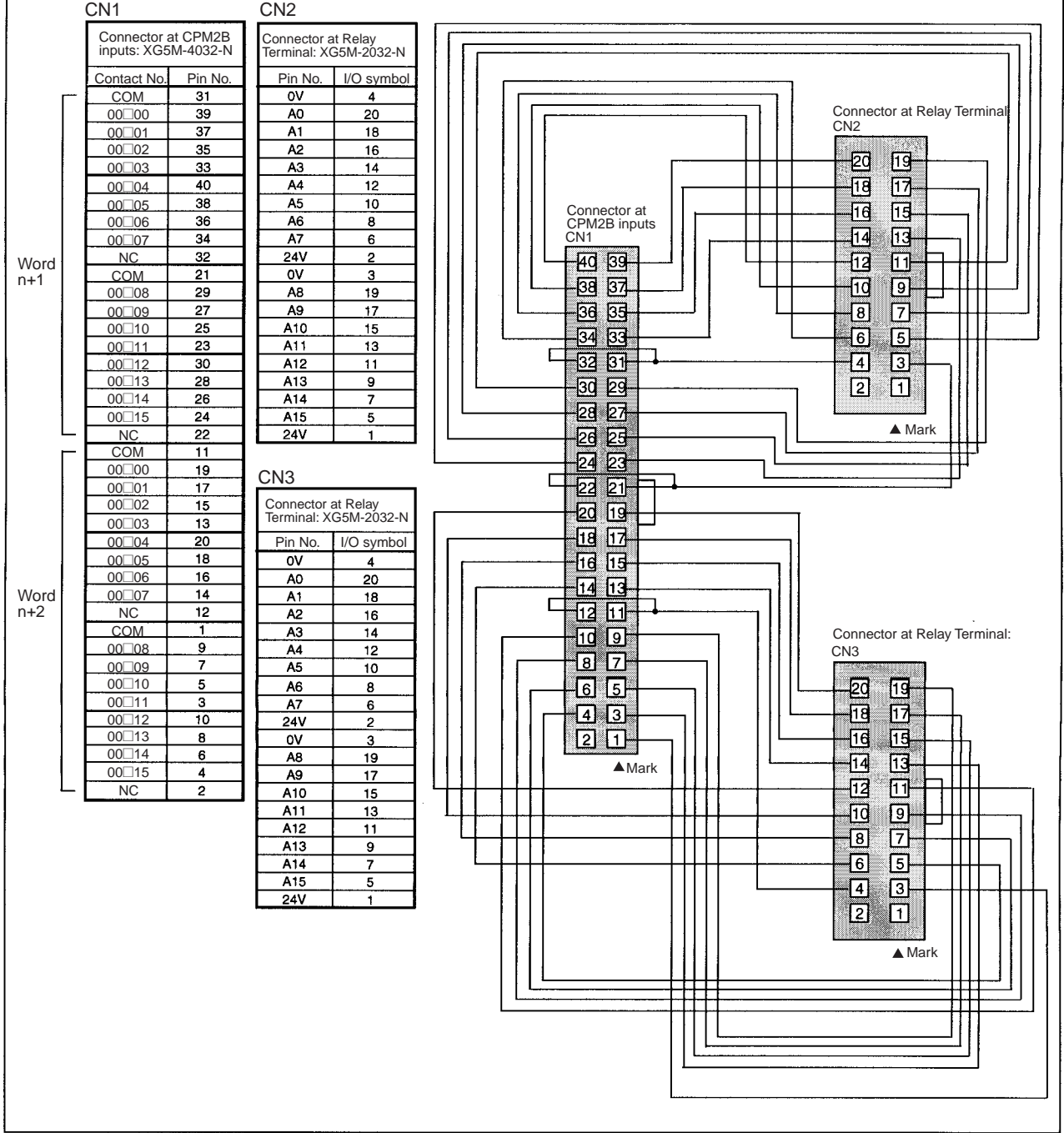

Index

Numerics

1:N connections, 13

A

arc killer

examples, xviii

ASCII

converting displays

Programming Console, 152

atmosphere, 24

B

battery

replacing, 175

binary data

modifying

Programming Console, 148

bit status

force-set/reset

Programming Console, 150

bits

searching

Programming Console, 137

buzzer operation

Programming Console, 131

C

cabinet

installation

precautions, 48

Programming Console installation, 125

cables

available models, 178, 180

characteristics, 25

checking

program syntax

Programming Console, 139

circuit configuration

inputs, 27

outputs

relay, 31

clearing

memory areas

Programming Console, 128

clearing memory, 129

clock

reading and setting the clock, 153

communications capabilities

overview, 5

components

Expansion I/O Boards, 37

conduit installation, 52

counters

changing SV

Programming Console, 146

example of inputting, 158

CPU Boards

available models, 177

dimensions, 181

CPU Units

cyclic operation, 19

internal structure, 15

CX-Programmer, 11

cycle time

displaying

Programming Console, 152

cyclic operation, 19

D

data

modifying

Programming Console, 145, 147, 150

data link, 6, 15

date

See also clock

decimal data with sign

See also signed decimal data

decimal data without sign

See also unsigned decimal data

dielectric strength, 24

differentiated instructions

entering, 134

dimensions, 181

displays

converting between hex and ASCII

Programming Console, 152

cycle time

Programming Console, 152

duct installation, 52

E

- EC Directives
 - precautions, xvi
- electrical noise
 - preventing, 48, 52
- ERR indicator
 - flashing, 165
 - lit, 165
- error log, 88
- errors
 - error processing, 161
 - fatal, 165
 - identifying, 163
 - non-fatal, 165
 - PC Setup, 83
 - reading/clearing messages
 - Programming Console, 130
 - user-defined errors, 164
- Expansion I/O Boards
 - available models, 177
 - components, 37
 - dimensions, 182
- Expansion I/O Cable
 - available models, 178
- expansion instructions
 - function codes, 94
 - reading and changing function code assignments, 131

F

- FAL numbers, 165
- FAL(06), 164
- FALS numbers, 165
- FALS(07), 164
- false inputs, 62
- fatal errors
 - troubleshooting, 168
- features, 2
- flash memory
 - precautions, 162
- flicker output
 - example, 158
- force-set/reset
 - clearing
 - Programming Console, 151
 - Programming Console, 150
- function codes
 - expansion instructions, 94

- reading and changing expansion instruction assignments, 131
- functions, 7

H

- hexadecimal data
 - converting displays
 - Programming Console, 152

I

- I/O capacity, 25
- I/O connectors
 - available models, 178
 - pin allocation
 - Expansion I/O Units, 40
 - wiring, 55
- I/O errors
 - troubleshooting, 170
- I/O line noise
 - preventing, 52
- I/O terminals
 - allocation
 - Expansion I/O Units, 40
- indicators
 - flashing ERR indicator, 165
 - lit ERR indicator, 165
 - PC status indicators, 35
- inductive loads, 63, 66
- initialization
 - time required, 17
- input devices
 - connecting, 60
- input specifications, 27, 30
- inputs
 - wiring, 57
- inrush current
 - suppressing, 67
- inspections, 174
- installation
 - site
 - selecting, 47
- instructions
 - expansion, 94
 - inserting and deleting
 - Programming Console, 138
 - mnemonics list
 - ladder, 91

- searching
 - Programming Console, 136
- insulation resistance, 24
- interlocks, 46
- interrupt program execution
 - in cyclic operation, 21

L

- leakage current, 62
- LED indicators, 35
- limit switches
 - preventing false inputs, 62

M

- maintenance, 174
- memory
 - backup, 26
 - clearing, 129
 - protection, 26
- memory areas
 - AR area bits
 - CPM2A/CPM2C, 79
 - clearing
 - Programming Console, 128
 - flags and control bits
 - CPM2A/CPM2C, 76
 - partial clear, 128
- messages
 - reading/clearing, 130
- mode
 - changing the PC mode, 122
- modes
 - operating modes, 16
- modifying
 - binary data
 - Programming Console, 148
 - data
 - Programming Console, 145
 - hexadecimal/BCD data
 - Programming Console, 147
 - signed decimal data
 - Programming Console, 149
 - SV
 - Programming Console, 146
 - unsigned decimal data
 - Programming Console, 150
- MONITOR mode

- description, 123
- example test run, 160
- monitoring
 - 3-word monitor
 - Programming Console, 143
 - binary monitor
 - Programming Console, 143
 - differentiation monitor
 - Programming Console, 142
 - signed decimal monitor
 - Programming Console, 144
 - status
 - Programming Console, 140
 - unsigned decimal monitor
 - Programming Console, 145
- motor control
 - capabilities, 3
- MSG(46), 164

N

- noise
 - preventing electrical noise, 48, 52
- noise immunity, 24
- non-fatal errors
 - troubleshooting, 169
- NPN current output
 - connecting, 60
- NPN open collector
 - connecting, 60
- NT Link
 - connections, 14

O

- operating conditions
 - troubleshooting, 172
- operating modes, 16
 - operating mode at startup, 17
- operation
 - preparations, 125
- output short protection, 66
- output specifications
 - relay output, 31
 - transistor output
 - sink type, 32
- output wiring
 - relay output, 63

P

panel
 Programming Console installation, 125

panel installation
 precautions, 48

password
 entering on Programming Console, 126

PC mode
 changing, 122

PC Setup
 See also settings

PC status
 indicators, 35

Peripheral Devices, 179
 available models, 179

photoelectric switches
 preventing false inputs, 62

PNP current output
 connecting, 60

position control, 3

power
 consumption, 24

power cables, 52

power interruption
 detection, 17

power supply
 precautions, 46
 troubleshooting, 167, 173
 wiring, 52

precautions
 design precautions, 46
 general, xi

program
 programming example, 153

program capacity, 25

program execution
 in cyclic operation, 20

program memory
 setting address and reading content
 Programming Console, 132

PROGRAM mode
 description, 123

programming
 checking the program, 159
 checks for syntax
 Programming Console, 139
 inserting and deleting instructions
 Programming Console, 138

 preparation for, 153
 searching
 Programming Console, 136, 137
 setting and reading a memory address
 Programming Console, 132
 special features, 94

Programming Console
 connecting, 124
 connections, 11
 keys, 120
 models, 120
 operations, 127

Programming Devices
 using, 119

programming example, 153

programs
 entering and editing
 Programming Console, 133

proximity switches
 preventing false inputs, 62

pulse control, 3

pulse outputs, 3
 wiring, 66

Q

quick-response inputs, 3

R

reading
 UM allocation information, 129

relay outputs
 connecting, 60

Relay Terminals
 connections, 56

RUN mode
 description, 123

S

search
 instruction
 Programming Console, 136
 operands
 Programming Console, 137

self-diagnosis functions, 26

self-diagnostic functions, 163

- self-holding bit
 - example, 156
- settings
 - changing, 82
- shock resistance, 24
- signed decimal data
 - modifying
 - Programming Console, 149
 - monitoring, 144
- specifications
 - characteristics, 25
 - general specifications, 24
 - input specifications, 27, 30
 - output specifications
 - relay output, 31
 - transistor output, sink type, 32
 - terminal blocks, 54
- status
 - monitoring
 - Programming Console, 140
- Support Software, 11
- SV
 - modifying
 - Programming Console, 146
- syntax
 - checking the program
 - Programming Console, 139
- SYSMAC Support Software, 11
- SYSMAC-CPT Support Software, 11
- system
 - checks, 162
- system configuration, 8

T

- temperature
 - operating, storage, 24
- temperature, ambient, 24
- terminal blocks
 - connections, 56
 - specifications, 54
 - wiring, 53
- test run
 - example, 160
 - procedure, 163
- time
 - See also* clock
- timers
 - changing SV

- Programming Console, 146
- example of inputting, 157
- troubleshooting, 166
 - fatal errors, 168
 - I/O errors, 170
 - non-fatal errors, 169
 - operating conditions, 172
 - power supply, 167, 173

U

- unsigned decimal data
 - modifying
 - Programming Console, 150
 - monitoring, 145
- user memory
 - allocation information, 129

V

- vibration resistance, 24
- voltage
 - supply voltage, 24
- voltage output
 - connecting, 60

W

- wiring, 51
 - I/O connectors, 55
 - power supply, 52
 - terminal blocks, 53

Revision History

A manual revision code appears as a suffix to the catalog number on the front cover of the manual.

Cat. No. W371-E1-03

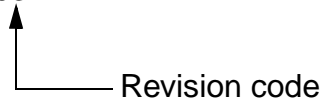

The following table outlines the changes made to the manual during each revision. Page numbers refer to the previous version.

Revision code	Date	Revised content
01	February 2000	Original production
02	September 2002	<p>Information related to new CPU Boards and Expansion I/O Boards was added throughout the manual, including information on 40-point CPU Boards and 40-point and 64-point Expansion I/O Boards. In addition, the following changes were made.</p> <p>The abbreviation "PC" for Programmable Controller changed to PLC throughout the manual.</p> <p>Page 2: Total I/O capacity changed and illustration modified.</p> <p>Page 3: Input time constant for 40-point and 64-point Input Expansion Boards added to <i>Stabilized Input Filter Function</i>.</p> <p>Page 4: Information on Host Link connections added and model number corrected in note.</p> <p>Page 6: Illustration changed and number of I/O points changed for CPU Board with 40 I/O points.</p> <p>Page 7: Extensive changes made.</p> <p>Page 8: Information on CX-Programmer added.</p> <p>Pages 8, 78, 81, 130: Information on CQM1H-PRO01-E Programming Console added.</p> <p>Page 10: Illustration corrected for the bottom graphic.</p> <p>Page 11: Changes made to note.</p> <p>Page 22: Changes made to ambient temperature specifications and models added.</p> <p>Page 23: Maximum I/O capacity changed.</p> <p>Page 24: Information on input time constant for new Boards.</p> <p>Pages 25 and 26: Addition to item 1 at bottom of page 25 and graphic added.</p> <p>Page 28: Information on limitations of the maximum switching capacity added for the 64-point Expansion I/O Board.</p> <p>Pages 29, 32, 33, and 34: Illustrations changed for Boards.</p> <p>Page 31: Information on DIP switch inputs changed.</p> <p>Page 38: Minor changes to table.</p> <p>Page 40: Note 3 changed.</p> <p>Pages 43 and 44: Tables of available models added.</p> <p>Page 54: Note 1 changed.</p> <p>Page 57: Example changed.</p> <p>Page 83: Information on automatic mode change added.</p> <p>Pages 90, 94, and 130: Programming Console model and graphic changed</p> <p>Page 129: Illustrations changed for CPU Boards and Expansion I/O Boards.</p> <p>Page 130: I/O Connectors table and specifications for PRO27-E changed.</p> <p>Page 131: Information on RS-422 Adapter changed.</p> <p>Pages 13 and 134: Changes and addition made and appendix C added.</p>

Revision History

Revision code	Date	Revised content
03	July 2003	<p>Information related to new CPU Boards and Analog I/O Boards was added throughout the manual, including the following changes.</p> <p>Page xiii: Precaution on connecting the PLC to a personal computer added.</p> <p>Page 2: Information on sharing programming devices changed.</p> <p>Page 4: Information on controlling analog I/O added.</p> <p>Page 7: Information on new 12-V DC CPU Board added to table.</p> <p>Page 8: Information on Expansion I/O Boards changed and column for word allocations added to table. New sub-section on system configuration of Analog I/O Boards added.</p> <p>Page 9: Information on Support Software changed.</p> <p>Page 10: Details on one-to-one computer connections changed and note referring to appendix removed.</p> <p>Page 22: Supply voltage for 12-V DC CPU Board added to general specifications table, and weight details removed.</p> <p>Page 25: Information for 12-V DC CPU Board added to I/O specifications table.</p> <p>Page 44: New sub-section added providing information on number of Expansion Boards that can be connected.</p> <p>Page 47: Information on hardware and cables for Expansion I/O Boards changed.</p> <p>Pages 49 and 50: Information on 12-V DC power supply added to subsection on power supply wiring.</p> <p>Page 55: New model number added to diagram.</p> <p>Page 66: Information on TR Area changed and table layout slightly changed.</p> <p>Pages 68 to 70: Information on I/O allocations for CPU Boards and Expansion I/O Boards changed, and information for I/O allocated to Analog I/O Boards added.</p> <p>Page 73: Information on AR Area word AR 02 changed.</p> <p>Page 91: New section added for Analog I/O Boards called <i>Section 6 Using Analog I/O Boards</i>.</p> <p>Page 99: Information on clearing memory and reading UM allocation added to table.</p> <p>Page 101: Details on clearing memory and reading UM allocation information added.</p> <p>Page 104: Table changed.</p> <p>Page 111: References corrected.</p> <p>Page 146: Table changed to add 12-V DC power supply.</p> <p>Page 149: New models added to information on standard models in appendix.</p> <p>Page 151: Peripheral devices information changed.</p> <p>Pages 153 to 156: Dimensions graphs changed to add new models.</p>

OMRON CORPORATION

FA Systems Division H.Q.
66 Matsumoto
Mishima-city, Shizuoka 411-8511
Japan
Tel: (81)55-977-9181/Fax: (81)55-977-9045

Regional Headquarters

OMRON EUROPE B.V.

Wegalaan 67-69, NL-2132 JD Hoofddorp
The Netherlands
Tel: (31)2356-81-300/Fax: (31)2356-81-388

OMRON ELECTRONICS LLC

1 East Commerce Drive, Schaumburg, IL 60173
U.S.A.
Tel: (1)847-843-7900/Fax: (1)847-843-8568

OMRON ASIA PACIFIC PTE. LTD.

83 Clemenceau Avenue,
#11-01, UE Square,
Singapore 239920
Tel: (65)6835-3011/Fax: (65)6835-2711

OMRON

Authorized Distributor:

Cat. No. W371-E1-03

SYSMAC CPM2B Programmable Controller

OPERATION MANUAL

OMRON

Read and Understand this Manual

Please read and understand this manual before using the product. Please consult your OMRON representative if you have any questions or comments.

Warranty and Limitations of Liability

WARRANTY

OMRON's exclusive warranty is that the products are free from defects in materials and workmanship for a period of one year (or other period if specified) from date of sale by OMRON.

OMRON MAKES NO WARRANTY OR REPRESENTATION, EXPRESS OR IMPLIED, REGARDING NON-INFRINGEMENT, MERCHANTABILITY, OR FITNESS FOR PARTICULAR PURPOSE OF THE PRODUCTS. ANY BUYER OR USER ACKNOWLEDGES THAT THE BUYER OR USER ALONE HAS DETERMINED THAT THE PRODUCTS WILL SUITABLY MEET THE REQUIREMENTS OF THEIR INTENDED USE. OMRON DISCLAIMS ALL OTHER WARRANTIES, EXPRESS OR IMPLIED.

LIMITATIONS OF LIABILITY

OMRON SHALL NOT BE RESPONSIBLE FOR SPECIAL, INDIRECT, OR CONSEQUENTIAL DAMAGES, LOSS OF PROFITS OR COMMERCIAL LOSS IN ANY WAY CONNECTED WITH THE PRODUCTS, WHETHER SUCH CLAIM IS BASED ON CONTRACT, WARRANTY, NEGLIGENCE, OR STRICT LIABILITY.

In no event shall the responsibility of OMRON for any act exceed the individual price of the product on which liability is asserted.

IN NO EVENT SHALL OMRON BE RESPONSIBLE FOR WARRANTY, REPAIR, OR OTHER CLAIMS REGARDING THE PRODUCTS UNLESS OMRON'S ANALYSIS CONFIRMS THAT THE PRODUCTS WERE PROPERLY HANDLED, STORED, INSTALLED, AND MAINTAINED AND NOT SUBJECT TO CONTAMINATION, ABUSE, MISUSE, OR INAPPROPRIATE MODIFICATION OR REPAIR.

Application Considerations

SUITABILITY FOR USE

OMRON shall not be responsible for conformity with any standards, codes, or regulations that apply to the combination of products in the customer's application or use of the products.

At the customer's request, OMRON will provide applicable third party certification documents identifying ratings and limitations of use that apply to the products. This information by itself is not sufficient for a complete determination of the suitability of the products in combination with the end product, machine, system, or other application or use.

The following are some examples of applications for which particular attention must be given. This is not intended to be an exhaustive list of all possible uses of the products, nor is it intended to imply that the uses listed may be suitable for the products:

- Outdoor use, uses involving potential chemical contamination or electrical interference, or conditions or uses not described in this manual.
- Nuclear energy control systems, combustion systems, railroad systems, aviation systems, medical equipment, amusement machines, vehicles, safety equipment, and installations subject to separate industry or government regulations.
- Systems, machines, and equipment that could present a risk to life or property.

Please know and observe all prohibitions of use applicable to the products.

NEVER USE THE PRODUCTS FOR AN APPLICATION INVOLVING SERIOUS RISK TO LIFE OR PROPERTY WITHOUT ENSURING THAT THE SYSTEM AS A WHOLE HAS BEEN DESIGNED TO ADDRESS THE RISKS, AND THAT THE OMRON PRODUCTS ARE PROPERLY RATED AND INSTALLED FOR THE INTENDED USE WITHIN THE OVERALL EQUIPMENT OR SYSTEM.

PROGRAMMABLE PRODUCTS

OMRON shall not be responsible for the user's programming of a programmable product, or any consequence thereof.

Disclaimers

CHANGE IN SPECIFICATIONS

Product specifications and accessories may be changed at any time based on improvements and other reasons.

It is our practice to change model numbers when published ratings or features are changed, or when significant construction changes are made. However, some specifications of the products may be changed without any notice. When in doubt, special model numbers may be assigned to fix or establish key specifications for your application on your request. Please consult with your OMRON representative at any time to confirm actual specifications of purchased products.

DIMENSIONS AND WEIGHTS

Dimensions and weights are nominal and are not to be used for manufacturing purposes, even when tolerances are shown.

PERFORMANCE DATA

Performance data given in this manual is provided as a guide for the user in determining suitability and does not constitute a warranty. It may represent the result of OMRON's test conditions, and the users must correlate it to actual application requirements. Actual performance is subject to the OMRON Warranty and Limitations of Liability.

ERRORS AND OMISSIONS

The information in this manual has been carefully checked and is believed to be accurate; however, no responsibility is assumed for clerical, typographical, or proofreading errors, or omissions.